

IP over Optical Networks - A Framework
draft-ip-optical-framework-01.txt

Bala Rajagopalan

James Luciani

Daniel Awduche

Brad Cain

Bilel Jamoussi

About this Draft

- Deals with the following issues:
 - IP transport over optical networks
 - IP-centric control plane for optical networks (MP?S-based)
- Defines terminology
- Describes the optical network model
- Describes service models
- Describes architectural alternatives
- Defines requirements
- Proposes an evolution path for IP over Optical capabilities

Outline

- Network and service models
- IP over Optical network services evolution
- The role of MP?S
- IP over Optical network architectures
- IP-centric control plane issues
- Conclusion

Outline

- Network and service models
 - Network Model
 - Domain Services Model
 - Unified Services Model
- IP over Optical network services evolution
- The role of MP?S
- IP over Optical network architectures
- IP-centric control plane issues
- Conclusion

IP over Optical: Model

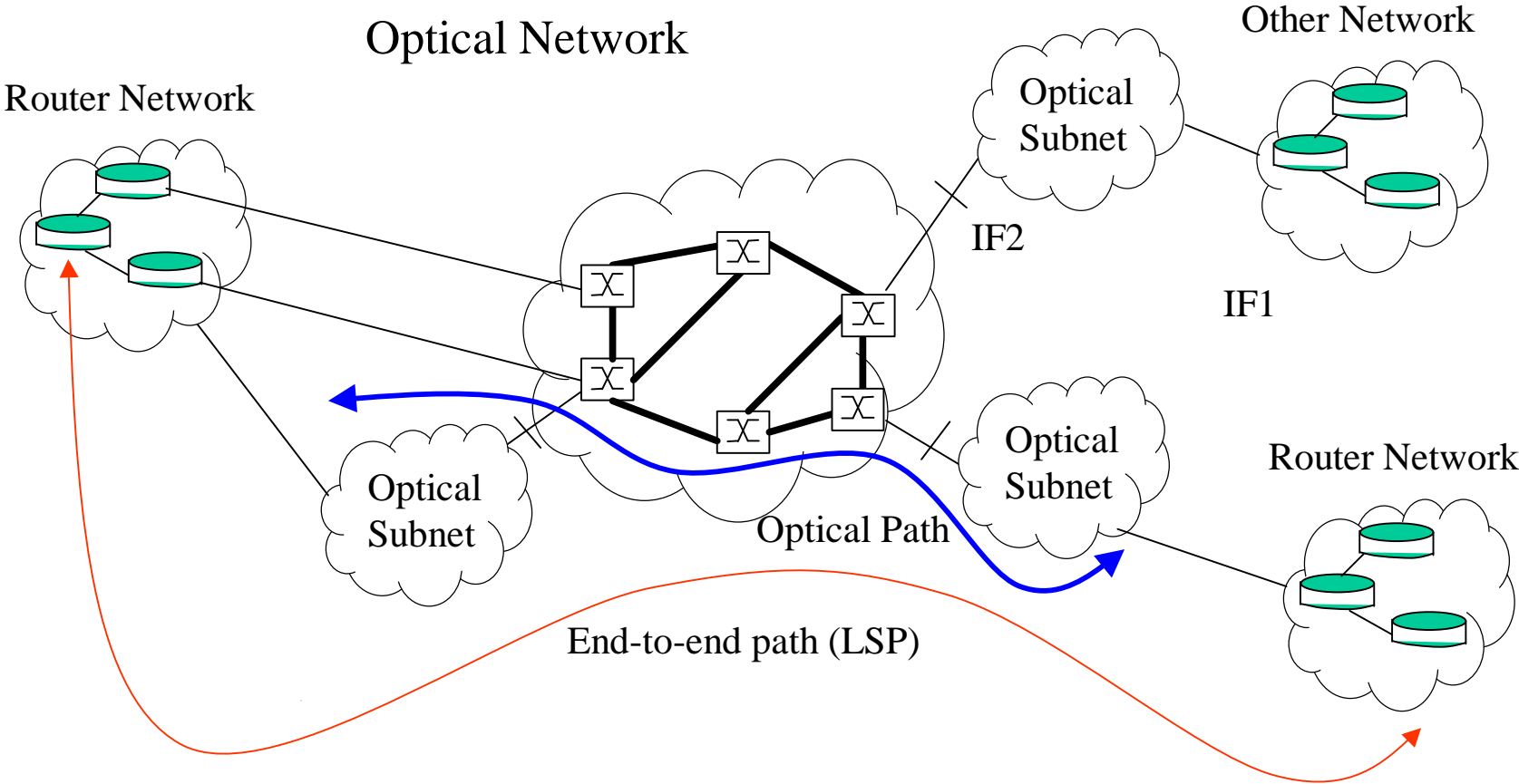

Service Models: Domain Services Model

- Optical network provides well-defined services (e.g., lightpath set-up)
- IP-optical interface is defined by actions for service invocation
- IP and optical domains operate independently; need not have any routing information exchange across the interface
- Lightpaths may be treated as point-to-point links at the IP layer after set-up

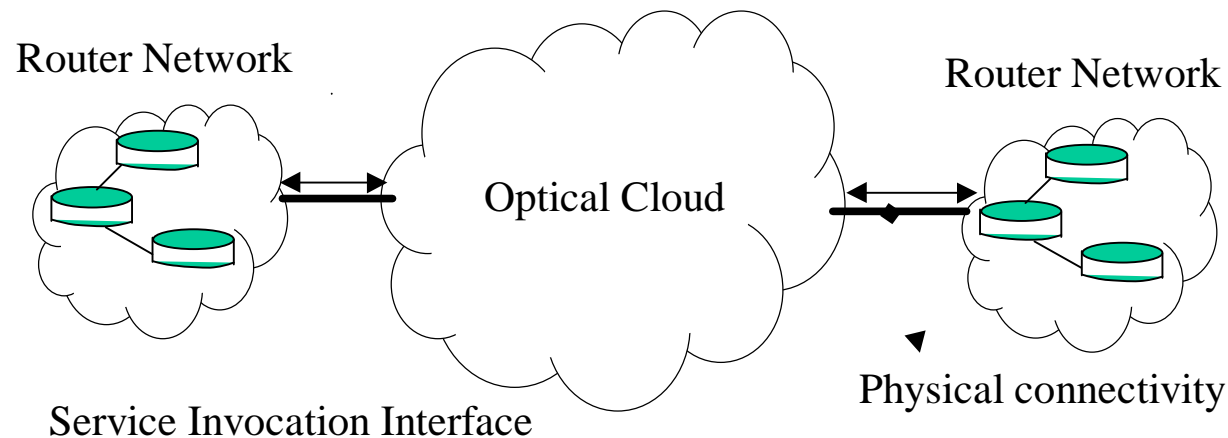

Domain Services Model: Lightpath Set-Up

1. Decision to establish lightpath (e.g., offline TE computations)
2. Request lightpath set-up
3. Internal optical network signaling
4. Lightpath set-up requested at destination
5. Lightpath set-up accepted
6. Internal optical network signaling
7. Successful lightpath set-up

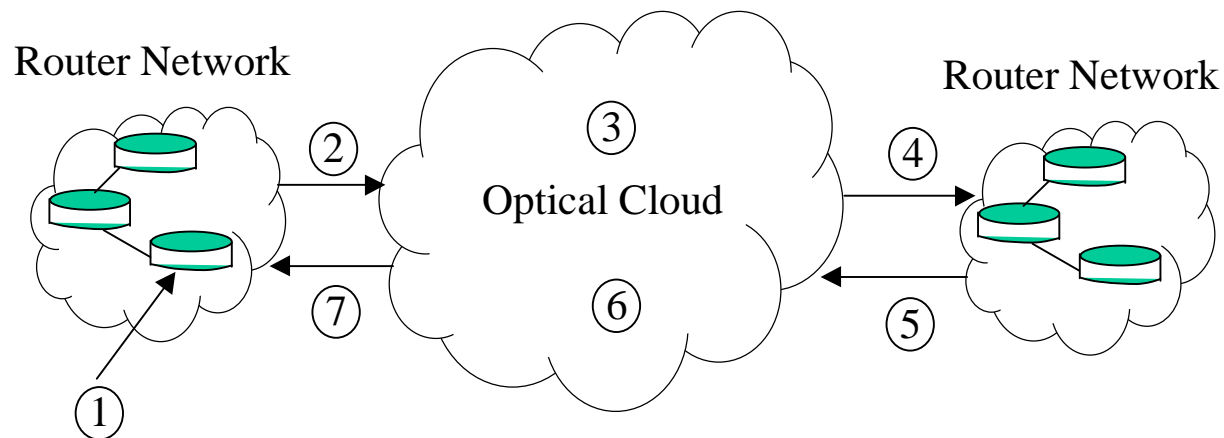

Service Models: Unified Service Model

- IP and optical network treated as a single integrated network for control purposes
- No distinction between IF1, IF2 and router-router (MPLS) control plane
- Services are not specifically defined at IP-optical interface, but folded into end-to-end MPLS services.
- Routers may control end-to-end path using TE-extended routing protocols deployed in IP and optical networks.
- Decision about lightpath set-up, end-point selection, etc similar in both models.

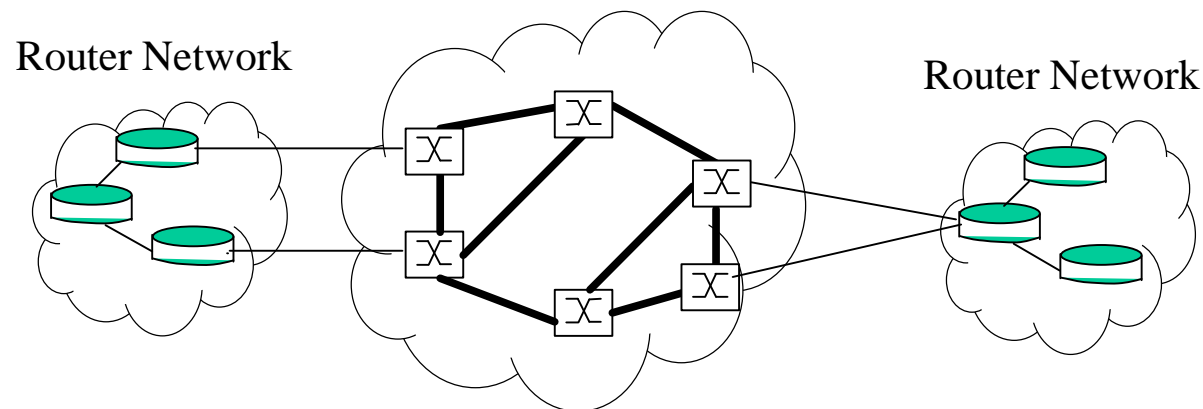

Unified Service Model: End-to-End Path Set-Up

1. Trigger for path set-up (e.g., TE decision)
2. End-to-end path computation (may use previously declared Fas, or visibility into optical network topology)
3. Forward signaling for path set-up
4. Reverse signaling for path set-up

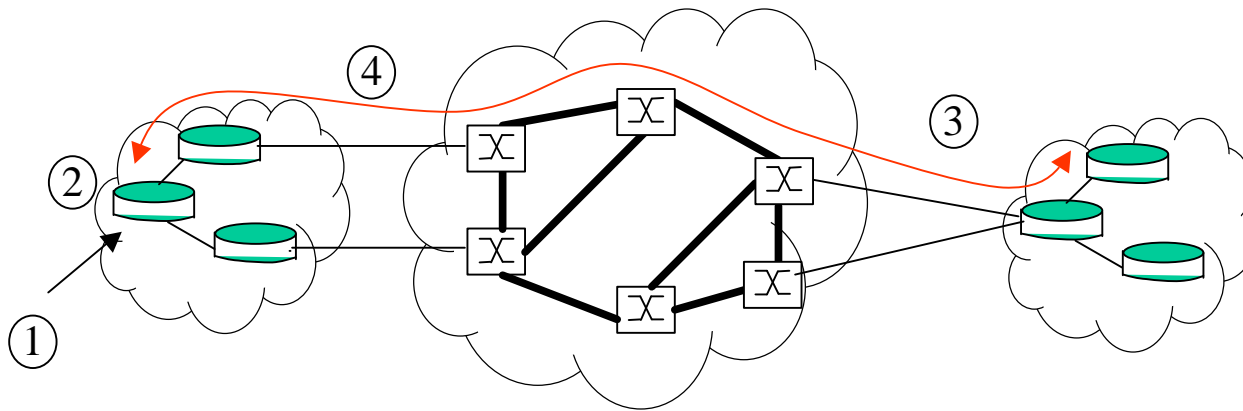

Outline

- Network and service models
- IP over Optical network services evolution
- The role of MP?S
- IP over Optical network architectures
- IP-centric control plane issues
- Conclusion

IP over Optical Services Evolution Scenario

- Definition of capability sets that evolve
- First phase: Domain services model realized using appropriate MP?S signaling constructs

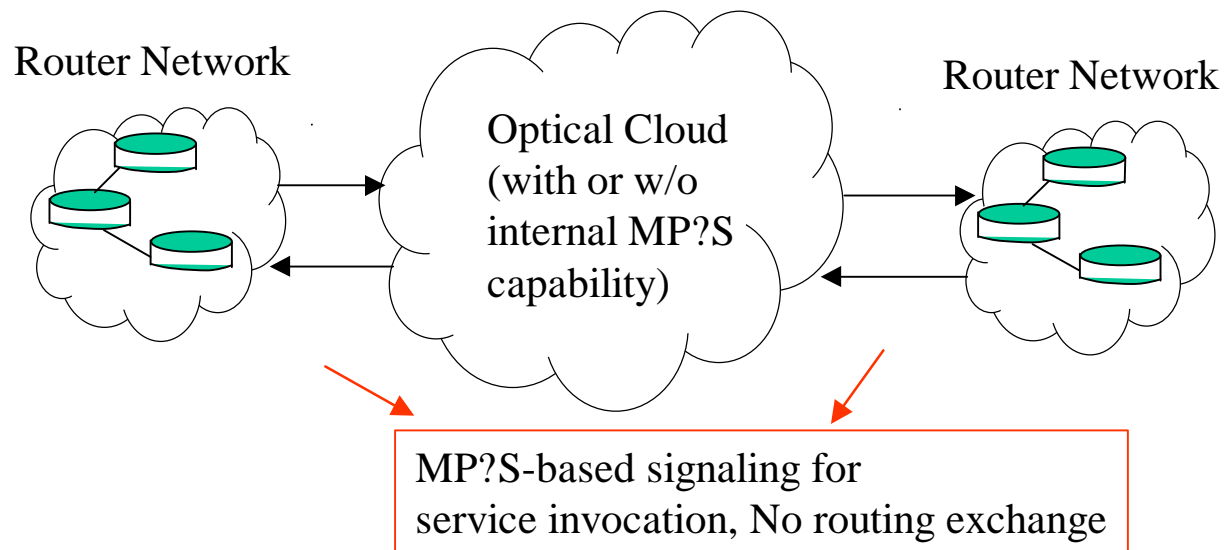

Evolution Scenario (contd.)

- Second phase: Enhanced MP?S signaling constructs for greater path control outside of the optical network. Abstracted routing information exchange between optical and IP domains.

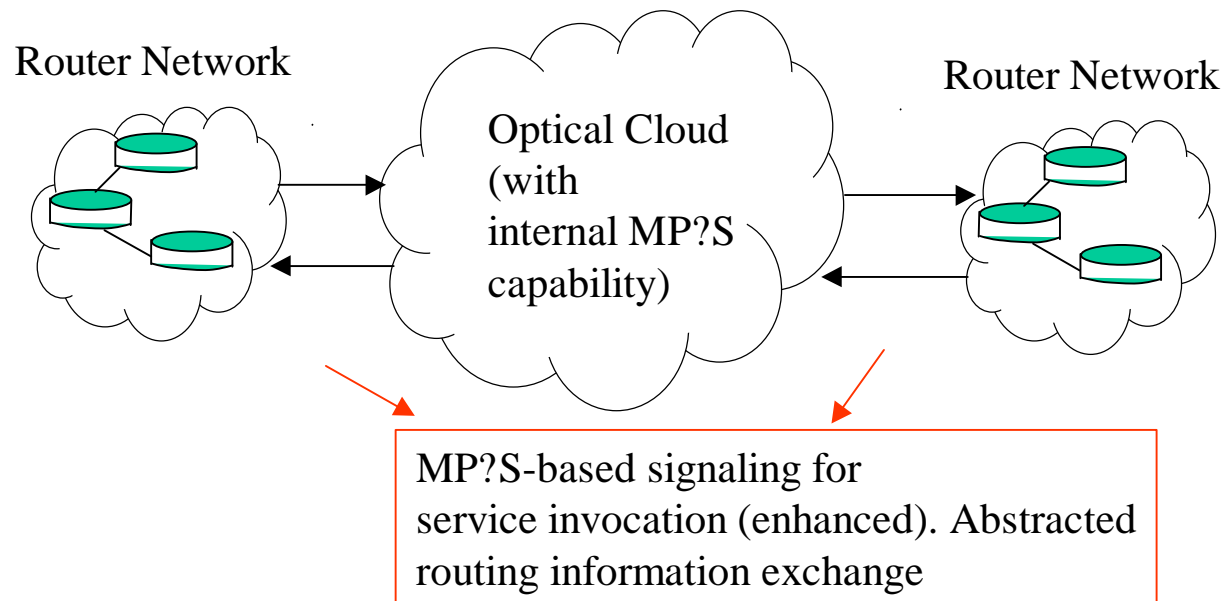

Evolution Scenario (Contd.)

- Phase 3: Peer organization with the full set of MP?S mechanisms.

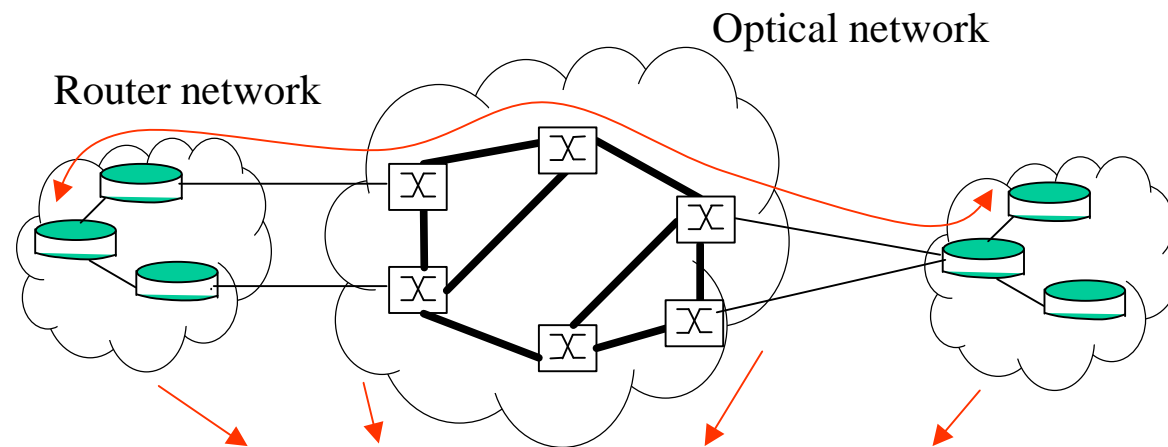

MP?S-based signaling for end-to-end path set-up.
MP?S-based signaling within IP and optical networks.
Full routing information exchange.

Outline

- Network and service models
- IP over Optical network services evolution
- **The role of MP?S**
- IP over Optical network architectures
- IP-centric control plane issues
- Conclusion

The Role of MP?S

- This framework assumes that MP?S will be the basis for supporting different IP over optical service models
- Main expectations:
 - Define signaling and routing mechanisms for accommodating IP over optical network service models
 - Define representations for addressable entities and service attributes
- Realize above within the framework of requirements for different service models
- Define a clear set of mechanisms for each set of (increasingly sophisticated) capabilities required
- Accommodate an evolution path for service capabilities

Outline

- Network and service models
- IP over Optical network services evolution
- The role of MP?S
- IP over Optical network architectures
 - Architectural alternatives
 - Routing approaches
- IP-centric control plane issues
- Conclusion

IP over Optical Networks: Architectural Models

- Architectural alternatives defined by control plane organization
 - Overlay model (loosely coupled control planes)
 - Augmented model (loosely coupled control planes)
 - Peer model (tightly coupled control planes)
- Routing approaches
 - Integrated routing (peer model)
 - Domain-specific routing (augmented model)
 - Overlay routing (overlay model)

Integrated Routing: OSPF

- Entire client-optical network treated as single network. Both client and optical networks run same version of OSPF protocol
- Client devices (routers) have complete visibility into optical network
- Clients compute end-to-end path
- Client border devices must manage lightpaths (bandwidth allocation, advertisement of virtual links, etc.)
- Determination of how many lightpaths must be established and to what endpoints are traffic engineering decisions

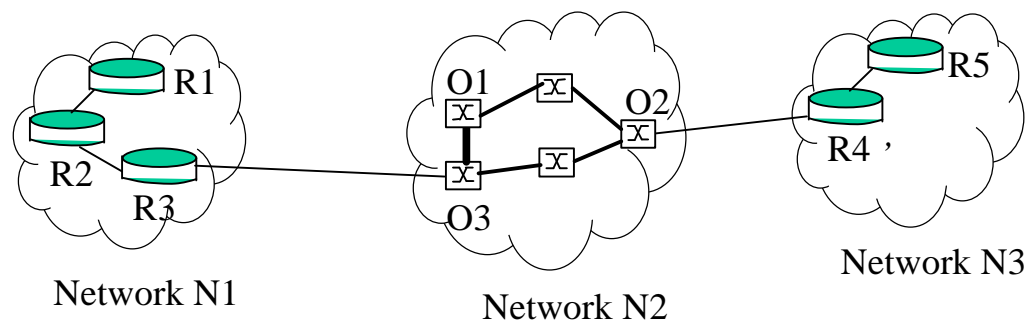

Domain-Specific Routing: BGP

- Client network sites belong to a VPON. Client border devices and border OXCs run E-BGP. Routing in optical and client networks can be different
- BGP/MPLS VPN model defined in draft-rosen-rfc2547bis-02.txt may be applied
- Determination of how many lightpaths must be established and to what endpoints are traffic engineering decisions

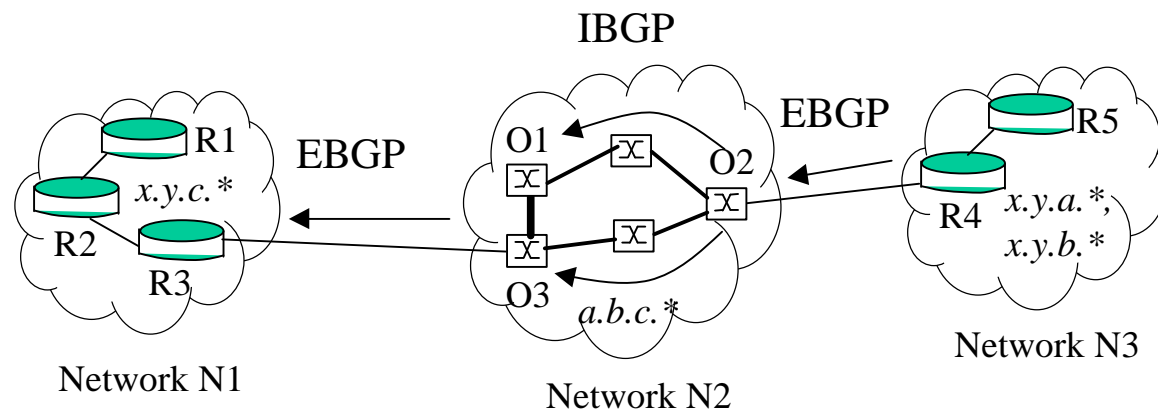

Overlay Routing

- Each client border router registers its address (and VPON id) with the optical network
- Optical network allows other client border routers belonging to the same VPON to query for addresses.
- IP routers establish lightpaths and run a routing protocol on the overlay topology
- Determination of how many lightpaths must be established and to what endpoints are traffic engineering decisions

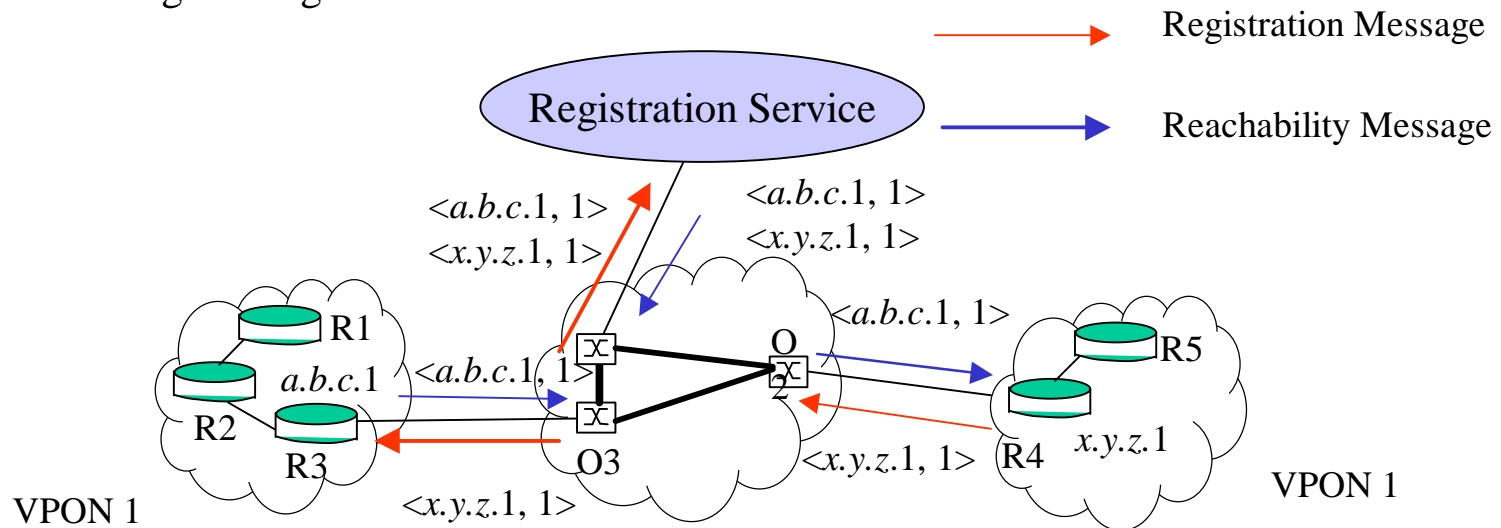

Outline

- Network and service models
- IP over Optical network services evolution
- The role of MP?S
- IP over Optical network architectures
- [IP-centric control plane issues](#)
- Conclusion

IP-centric Control Plane: Main Issues

- Control procedures within and between sub-networks are distinguished.
- MP?S control plane is assumed. Issues considered:
 - Identification
 - Neighbor discovery
 - Topology discovery
 - Restoration models
 - Route computation
 - Signaling issues
 - Optical internetworking

Identification

- Termination point identification in optical networks
 - Possible structure: Node, Port, Channel, Sub-channel
- Trail segment identification between adjacent OXCs
 - MP?S labels with the required structure (e.g., port, channel, sub-channel)
- SRLG Identifiers: Flat identifiers?

Neighbor Discovery

- To determine the local link connectivity between adjacent OXCs
 - Serves as the first step towards topology discovery
 - Required for specifying MP/S labels over optical links
- Neighbor discovery over opaque and transparent links
 - Procedures TBD
 - LMP is referred as a possibility

Topology Discovery

- Link state protocol recommended
- Bundling recommended to reduce number of adjacencies and links represented
- Bundling structure is TBD.
- The encoding of restoration-related parameters for computing shared protection paths is TBD

Route Computation & Signaling

- Route computation with SRLG constraints is discussed
- Signaling issues described
 - Bi-directional lightpaths
 - Fault-tolerance
 - Signaling for restoration

Optical Internetworking

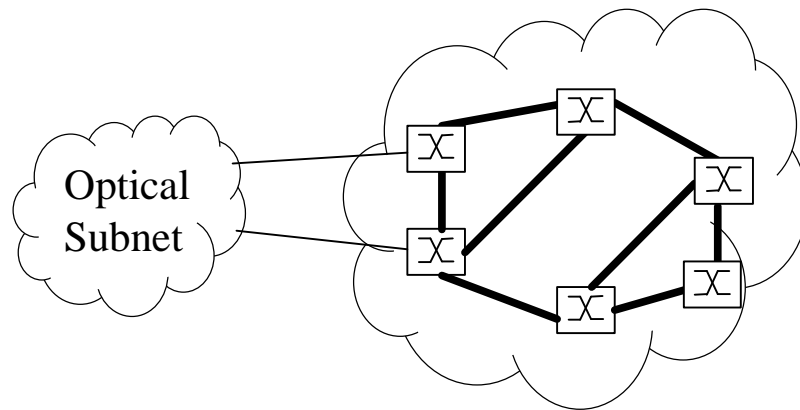

Requirements discussed:

- Common, global addressing scheme for optical path endpoints
- Propagation of reachability information
- End-to-end path provisioning using signaling
- Policy support (accounting, security, etc)
- Support for subnet-proprietary provisioning and restoration algorithms

Optical Control Plane: Restoration

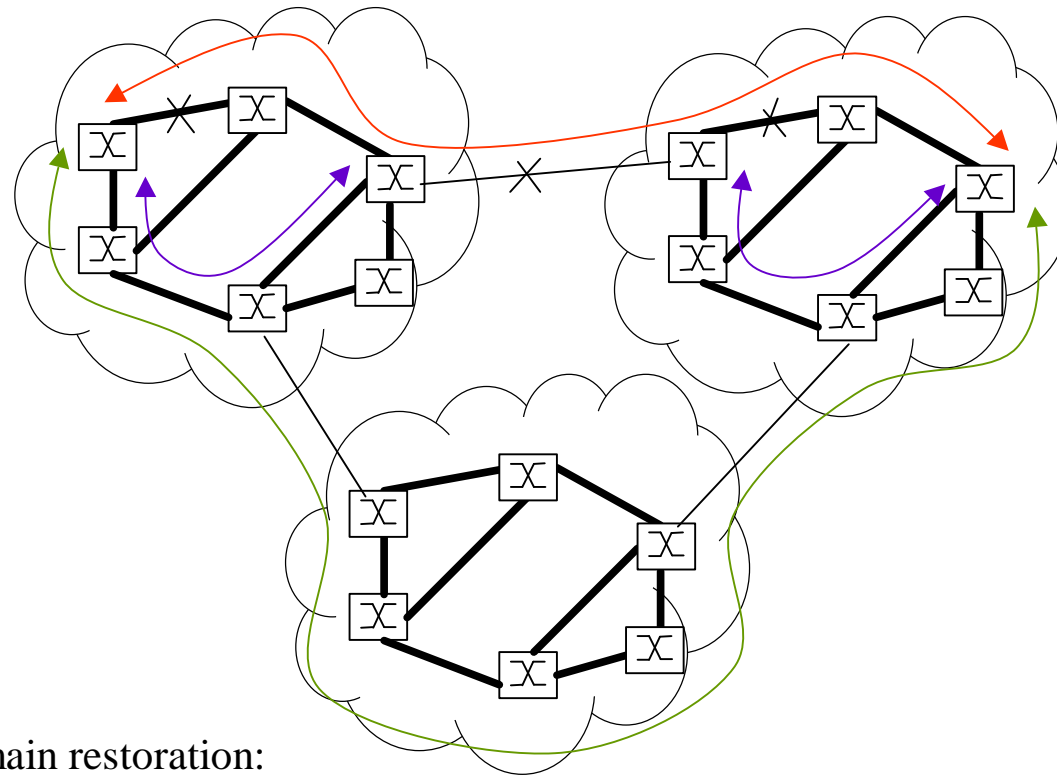

Multi-domain restoration:

- Allow possibility of proprietary restoration in each subnetwork
- Specify an overall end-to-end restoration scheme as backup.
- Signaling and routing for end-to-end restoration

Conclusion

- The draft gives a high-level overview of IP over Optical service models and architectures
- Recommends an evolutionary approach to IP over optical, starting from simple capabilities and going to more sophisticated capabilities
- IP over Optical requirements not yet defined in the framework
 - Domain services model requirements available
- Restoration issues require further discussion
- IP over optical traffic engineering issues need coverage