

Native SHIM APIs

Miika Komu <miika@iki.fi>

Helsinki Institute for Information Technology

About the Draft

- The draft has been earlier on HIP RG
- Differences to the earlier draft
 - Generalized the text (could be used also by BTNS, and maybe SHIM6?)
 - Used a separate resolver function call earlier, now uses the standard getaddrinfo
- Contributions
 - A new indirection/abstraction called endpoint descriptor
 - Applications gain more control of SHIM Layer
 - Application can specify its own public keys

End-point Descriptors

- ED = End-point Descriptor
 - 32 bit value
 - Acts as a token or handle to a HI
- Why not HI or HIT?
 - ED hides the presentation of HIs from most apps
 - Deployment of new identifiers/layers (service/session?) is easier because applications do not have to be modified
 - Implementing opportunistic mode and application specified identifiers (variable sized public keys) becomes easier

ED Bindings

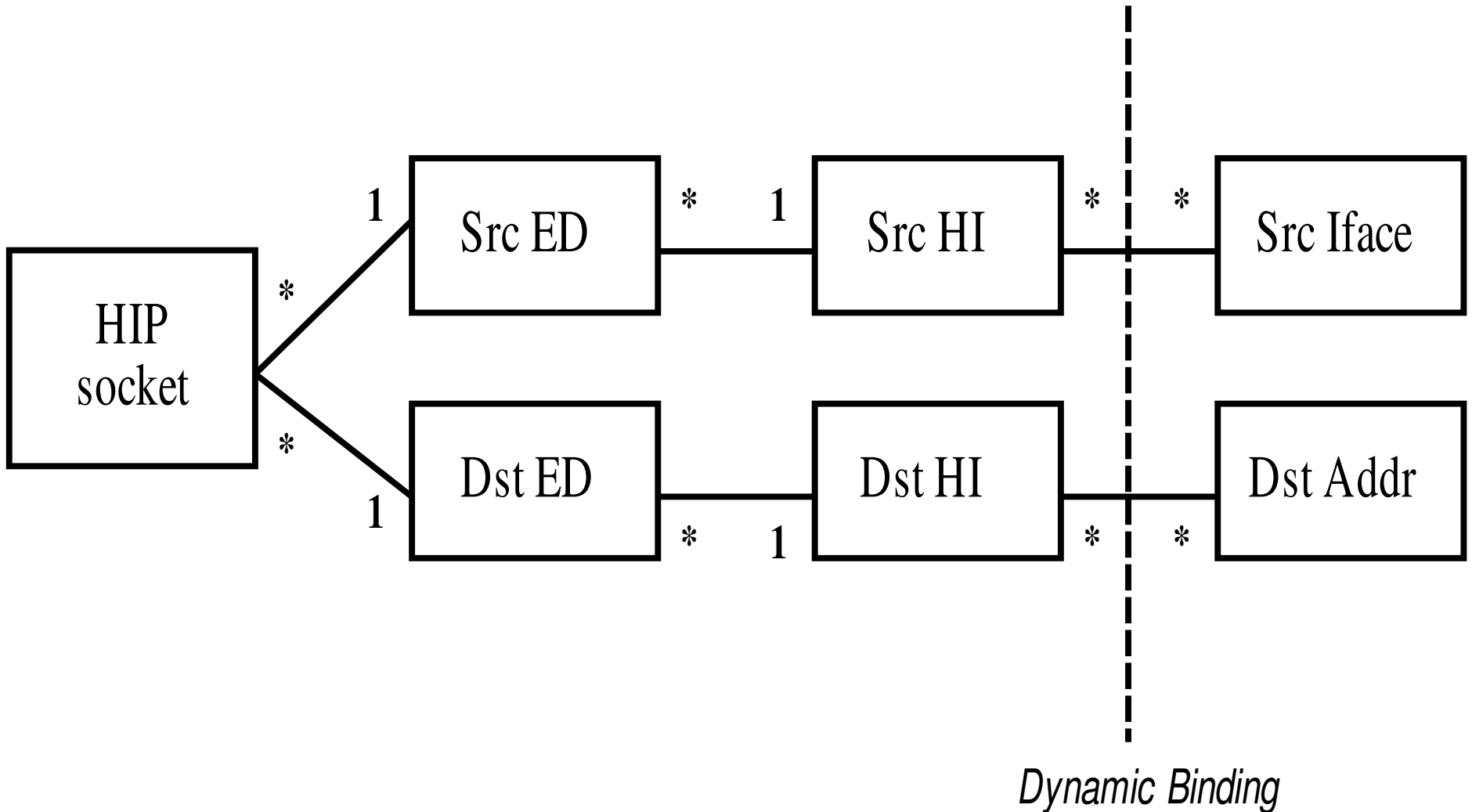

API Layering

| | | | |
|-------------------|-------------|----------|----------|
| Application Layer | Application | | |
| Socket Layer | IPv4 API | IPv6 API | SHIM API |
| Transport Layer | TCP | | UDP |
| HIP Layer | HIP | | |
| Network Layer | IPv4 | | IPv6 |
| Link Layer | Ethernet | | |

Naming

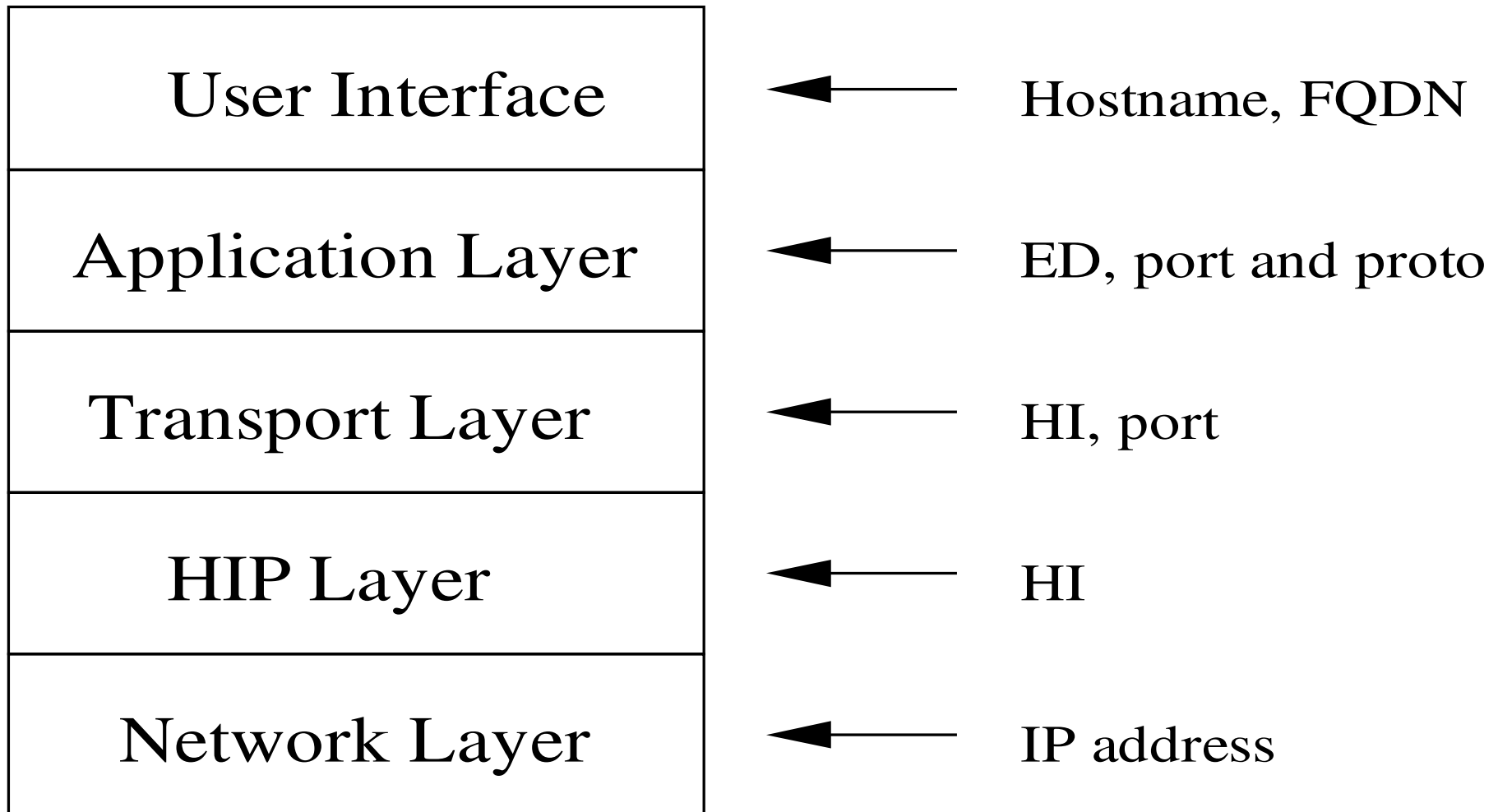

Legacy APIs

- Suitable for non-SHIM aware applications
 - Applications need no changes
 - Easier deployment path
- Applications use HITs or LSIs to establish connections using HIP
 - No new socket handler required
 - The use of IP addresses is also possible
- <http://www.ietf.org/internet-drafts/draft-henderson-hip-applications-03.txt>

Native SHIM API

- Suitable for new SHIM aware applications
 - Applications can control the SHIM layer better
- Introduces a new socket family: PF_SHIM
 - Detection of SHIM support in the localhost
 - Can be used for communicating user or application specified Host Identifiers
- Introduces a new socket address structure with new identifier: Endpoint Descriptor (ED)
 - Similar to file descriptor, only local significance

Legacy vs. Native SHIM API

```
struct addrinfo hints, *res, *try;

char *hello = "hello";

int err, bytes, sock;

memset(hints, 0, sizeof(hints));

//hints.ai_family = AF_INET6;

hints.ai_socktype = SOCK_STREAM;

err = getaddrinfo("www.host.org", "echo",
                 &hints, &res);

sock = socket(res->ai_family, res->ai_socktype,
              res->protocol); // family=AF_INET6

for (try = res; try; try = try->ai_next)
    err = connect(sock, try->ai_addr,
                 try->ai_addrlen);
    bytes = send(sock, hello, strlen(hello), 0);
    bytes = recv(sock, hello, strlen(hello), 0);

err = close(sock);
err = freeaddrinfo(res);
```

```
struct addrinfo hints, *res, *try;

char *hello = "hello";

int err, bytes, sock;

memset(hints, 0, sizeof(hints));

hints.flags = AI_ED;

//hints.family = AF_SHIM;

hints.ai_socktype = SOCK_STREAM;

err = getaddrinfo("www.host.org", "echo",
                 &hints, &res);

sock = socket(res->ai_family, res->ai_socktype,
              res->protocol); // family=PF_SHIM

for (try = res; try; try = try->ai_next)
    err = connect(sock, try->ai_addr,
                 try->ai_addrlen);
    bytes = send(sock, hello, strlen(hello), 0);
    bytes = recv(sock, hello, strlen(hello), 0);

err = close(sock);
err = freeendpointinfo(res);
```

Application Specified Identifiers

```
int sockfd, err, family = PF_SHIM, type = SOCK_STREAM;
```

```
char *user_priv_key = "/home/mk/hip_host_dsa_key";
```

```
struct endpoint *endpoint;
```

```
struct sockaddr_ed my_ed;
```

```
struct addrinfo hints, *res = NULL;
```

```
err = load_hip_endpoint_pem(user_priv_key, &endpoint);
```

```
err = setmyeid(&my_ed, "", endpoint, NULL);
```

```
sockfd = socket(family, type, 0);
```

```
err = bind(sockfd, (struct sockaddr *) &my_ed,  
          sizeof(my_ed));
```

```
memset(&hints, 0, sizeof(&hints));
```

```
hints.ai_socktype = type;
```

```
hints.ai_family = family;
```

```
hints.flags = AI_ED;
```

```
err = getendpointinfo("www.host.org", "echo", &hints, &res);
```

```
/* connect, send and recv normally */
```

Implementation

- <http://infracore.fi/>
- Linux based implementation
 - the resolver extensions
 - application specified identifiers
 - kernelspace socket handler

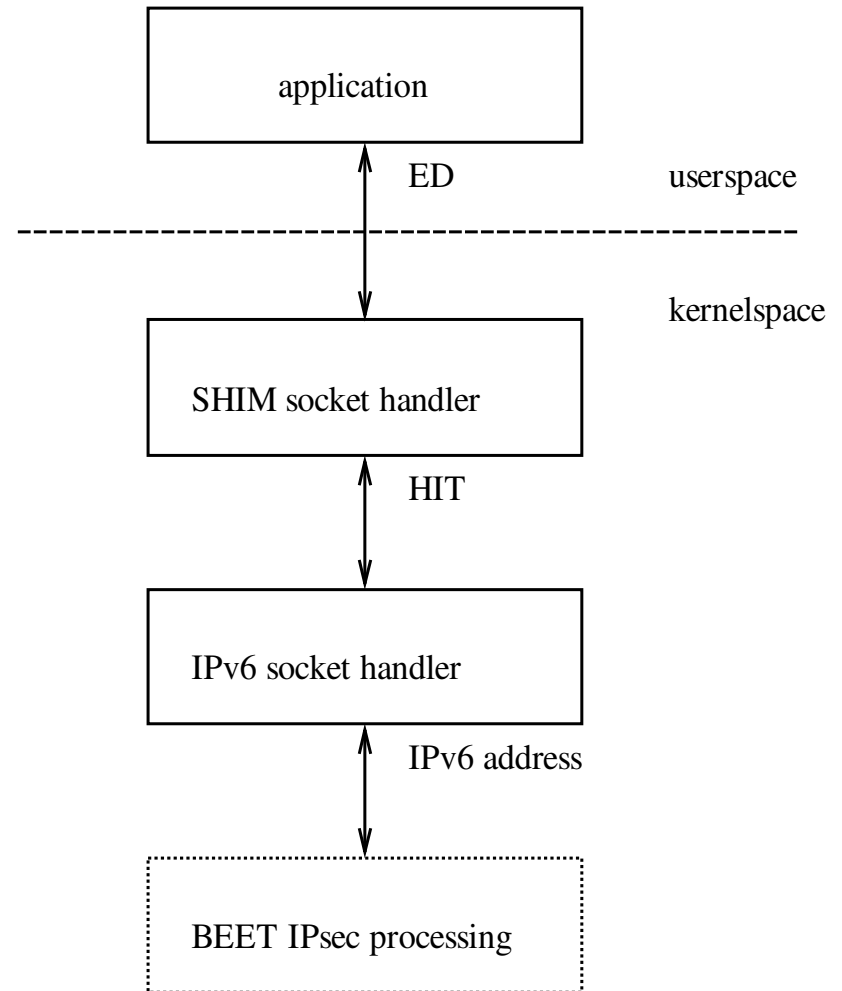

Summary

- ED hides the presentation of HITs and HIs
 - Opportunistic HIP
 - Deployment of new identifier layers
 - Size of HIT may change in the future
- PF_SHIM family can be used e.g. for detecting SHIM support in the localhost
- Native SHIM API extends HIP architecture by allowing apps to have their own id

Open Issues

- Use EDs or HITs?
- Semi-legacy APIs required?
 - Applications use HITs but are able to set HIP specific (system-wide) socket options
- Applicability to BTNS
- Accept as a official WG item?

Related Work

- Applying a Cryptographic Namespace to Applications [Komu et al]
- draft-mkomu-hip-native-api-00
- Application Programming Interfaces for Host Identity Protocol [Komu]
- draft-henderson-hip-applications
- draft-sugimoto-multihome-shim-api

Questions / Feedback

Miika Komu <miika@iki.fi>

Helsinki Institute for Information Technology