

# Nested NEMO RO

---

Use Cases,  
Issues & Requirements  
in the MANEMO Scenarios

# A slide from Mobile Networks (monet) Bof, March 2002

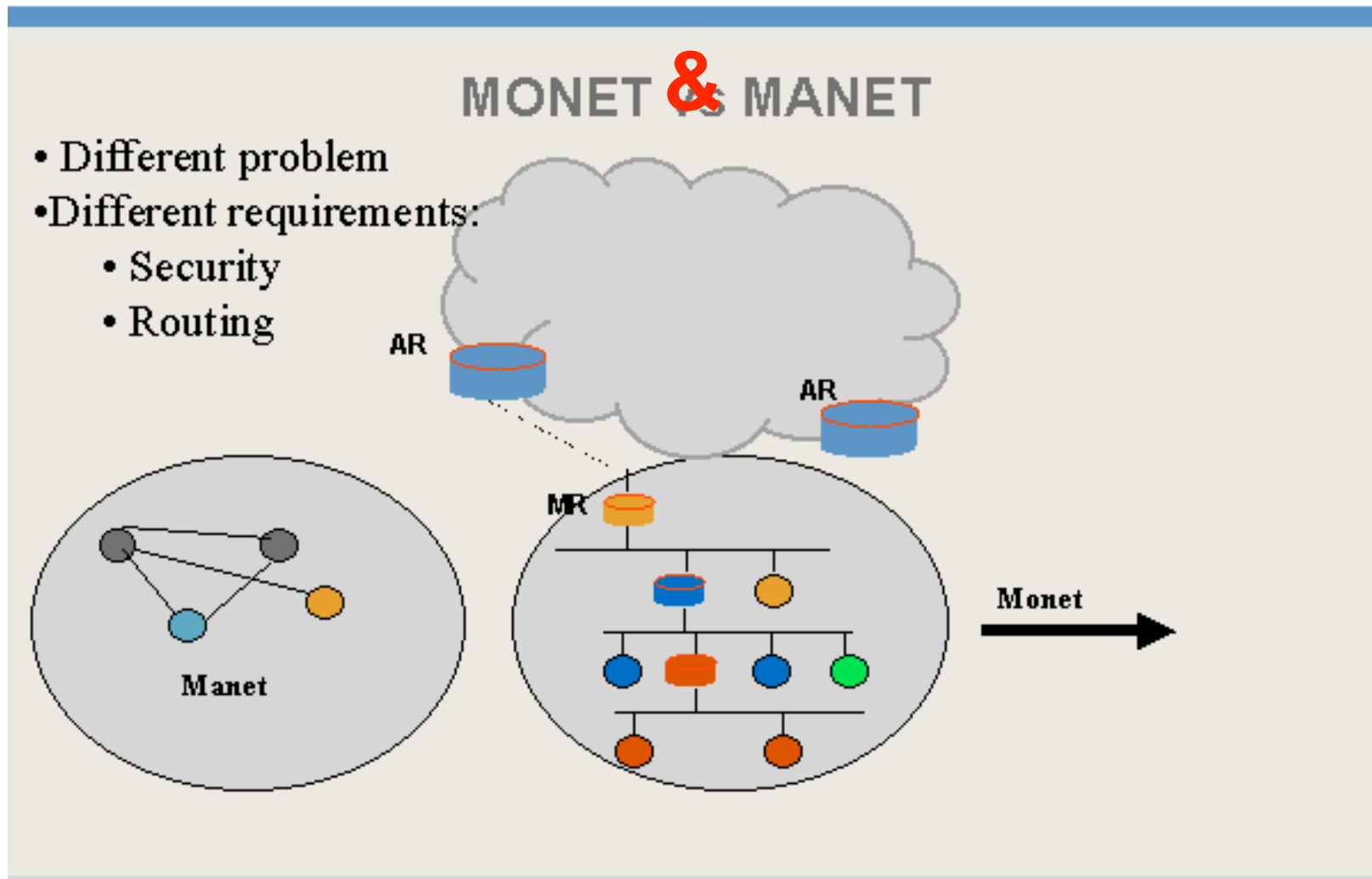

# A slide from Mobile Networks (monet) Bof, March 2002

## Nested MONETs

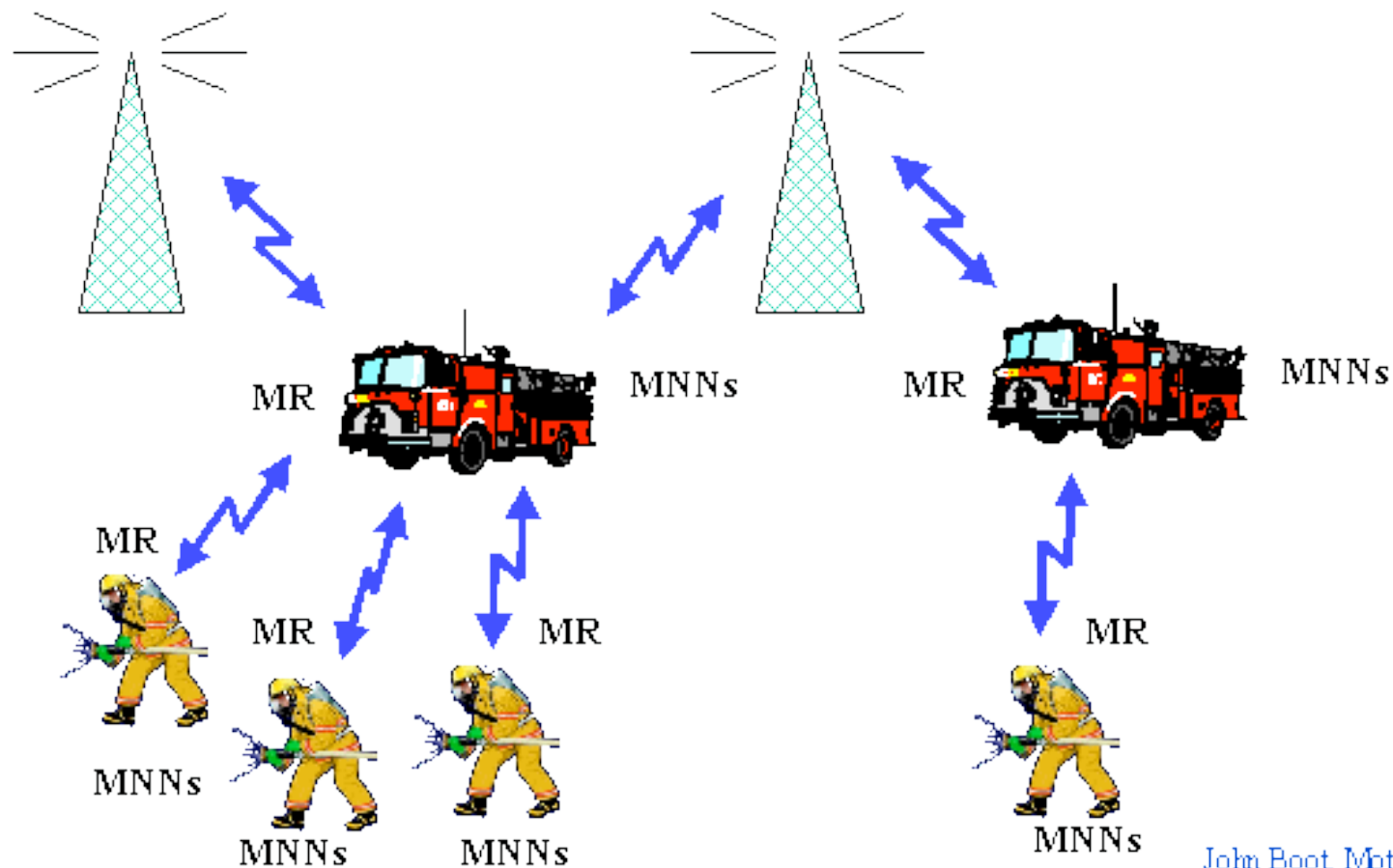

# Vehicular Communication

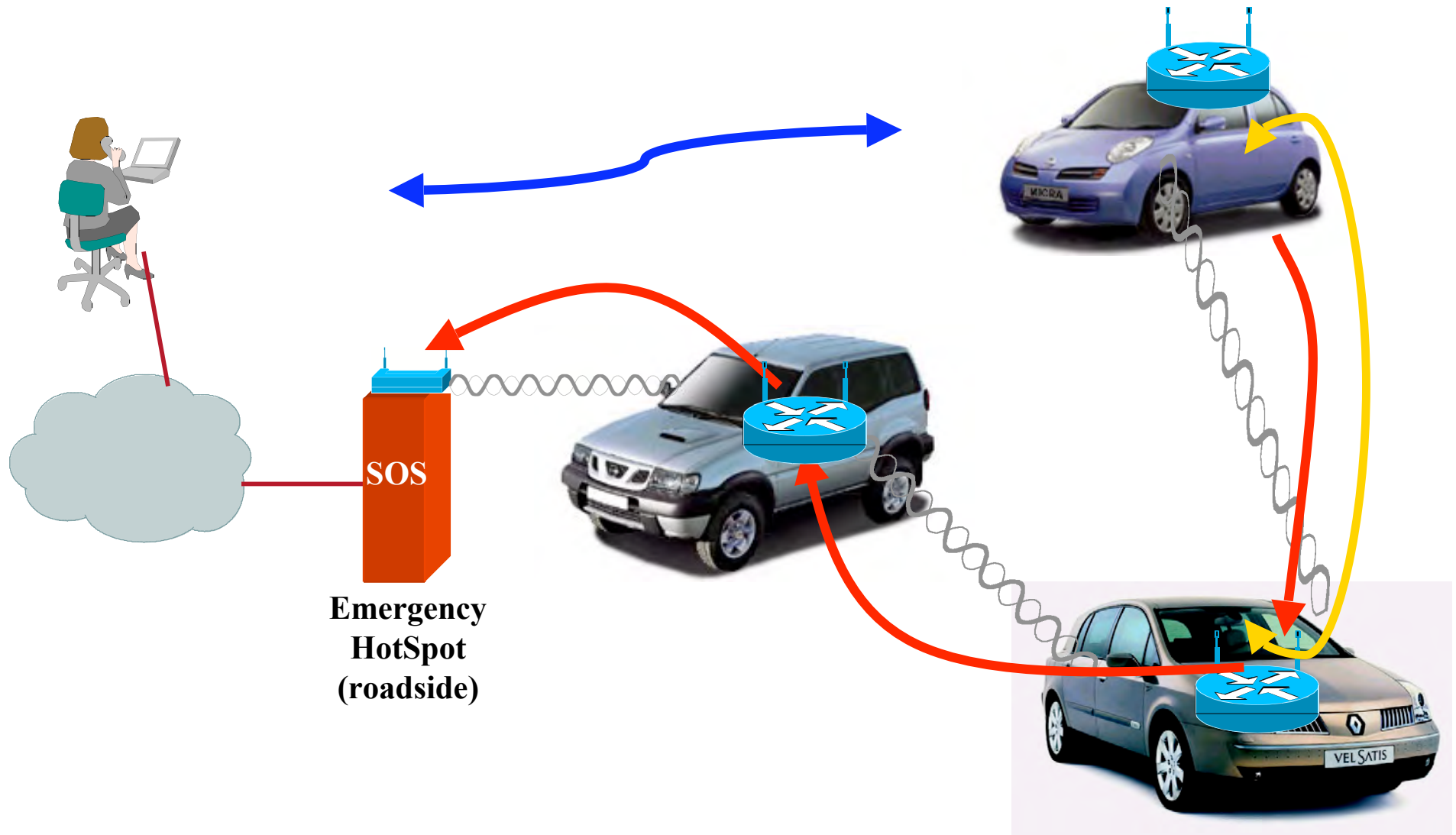

# Sensors Network

- “Sensor dust” spread over a territory
- Sensors assume a fixed arbitrary geographical distribution
- numerous sensors with limited capabilities (LFN == RFD\*)
- A limited number of relays (MR == FFD\*)
- Few uplinks (MR with backhaul capability)
- Mobile Sensors, mobile Sinks

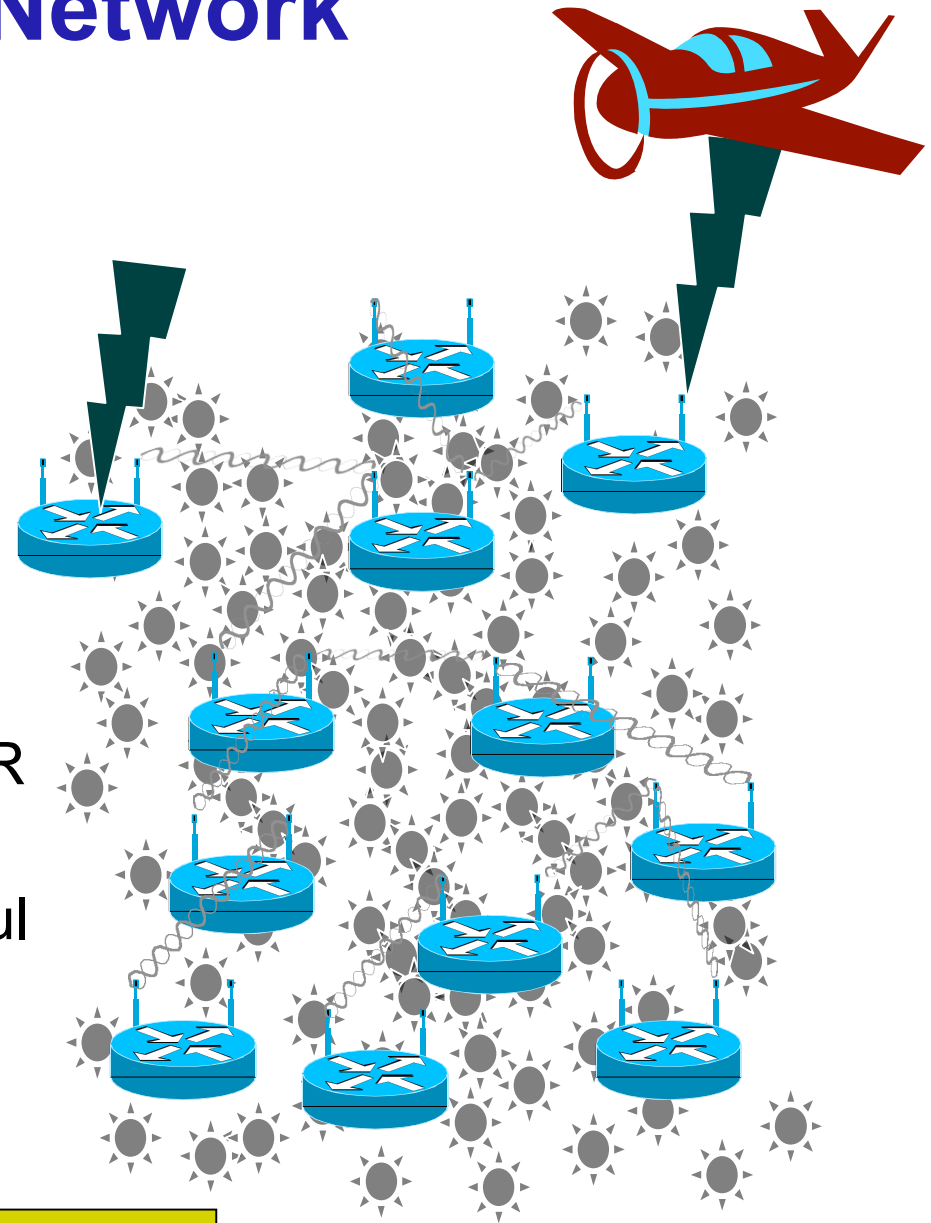

\* Reduced and Full Functions Devices

# Mesh Network (ex. Fleet in motion)

- **Global motion plus relative mobility**
- **Managed hierarchy**
- **Secured uplink to base**
- **Local connectivity**
- **Movement Aware peer selection**
- **Wireless dynamic coverage extension by moving ships**

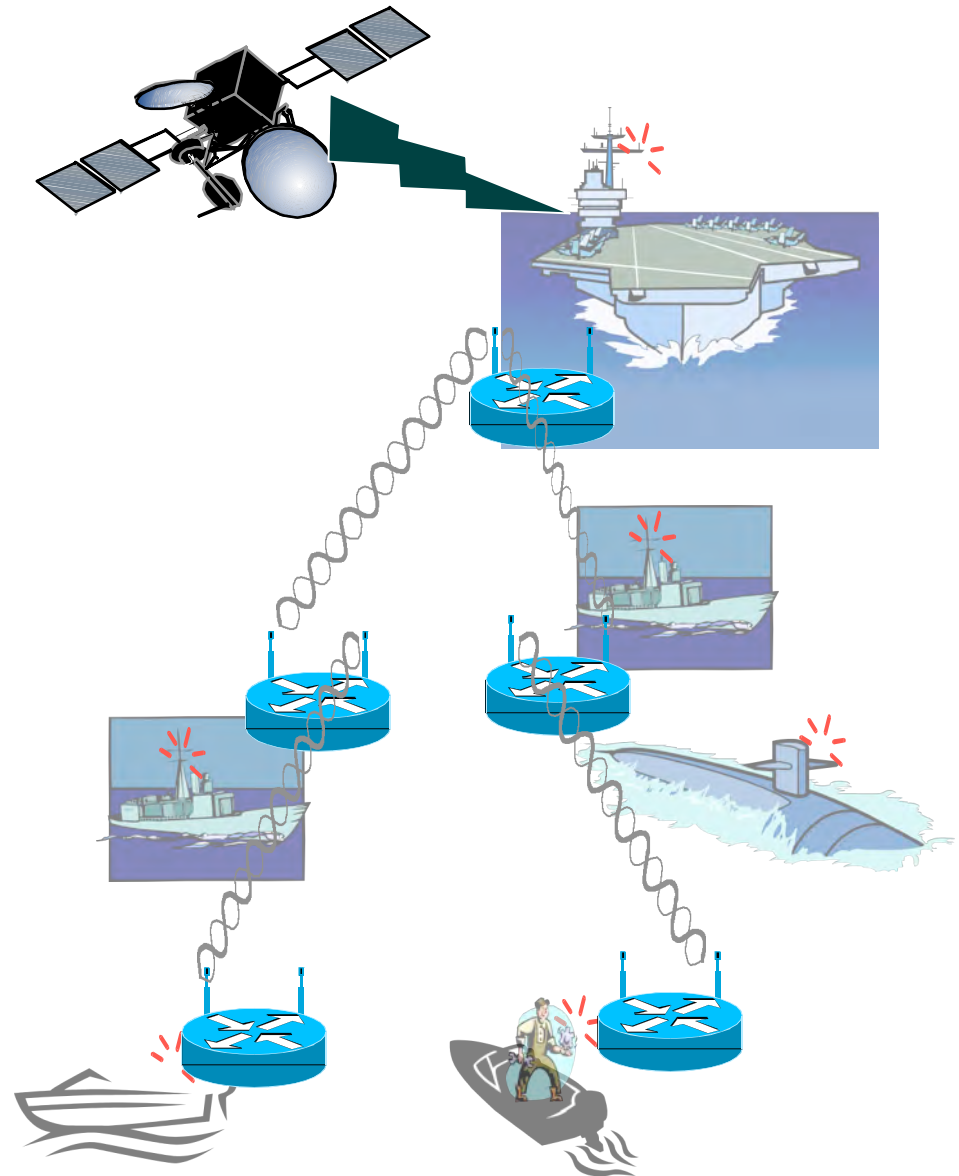

# U-2010 (2006 – 2008)

[www.u2010.org](http://www.u2010.org)



U-2010

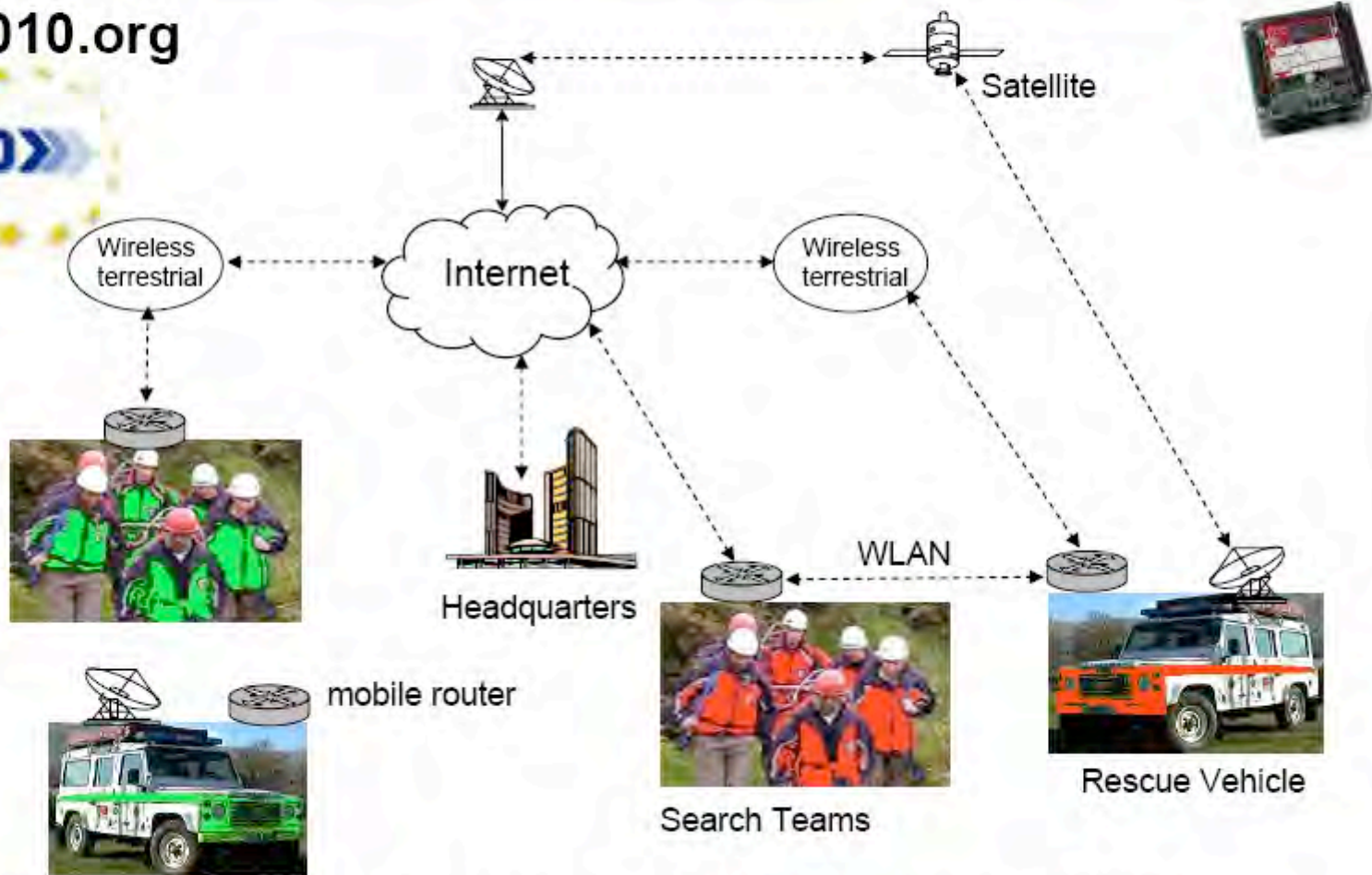

# Communications between multiple initial responder independent networks using MWF

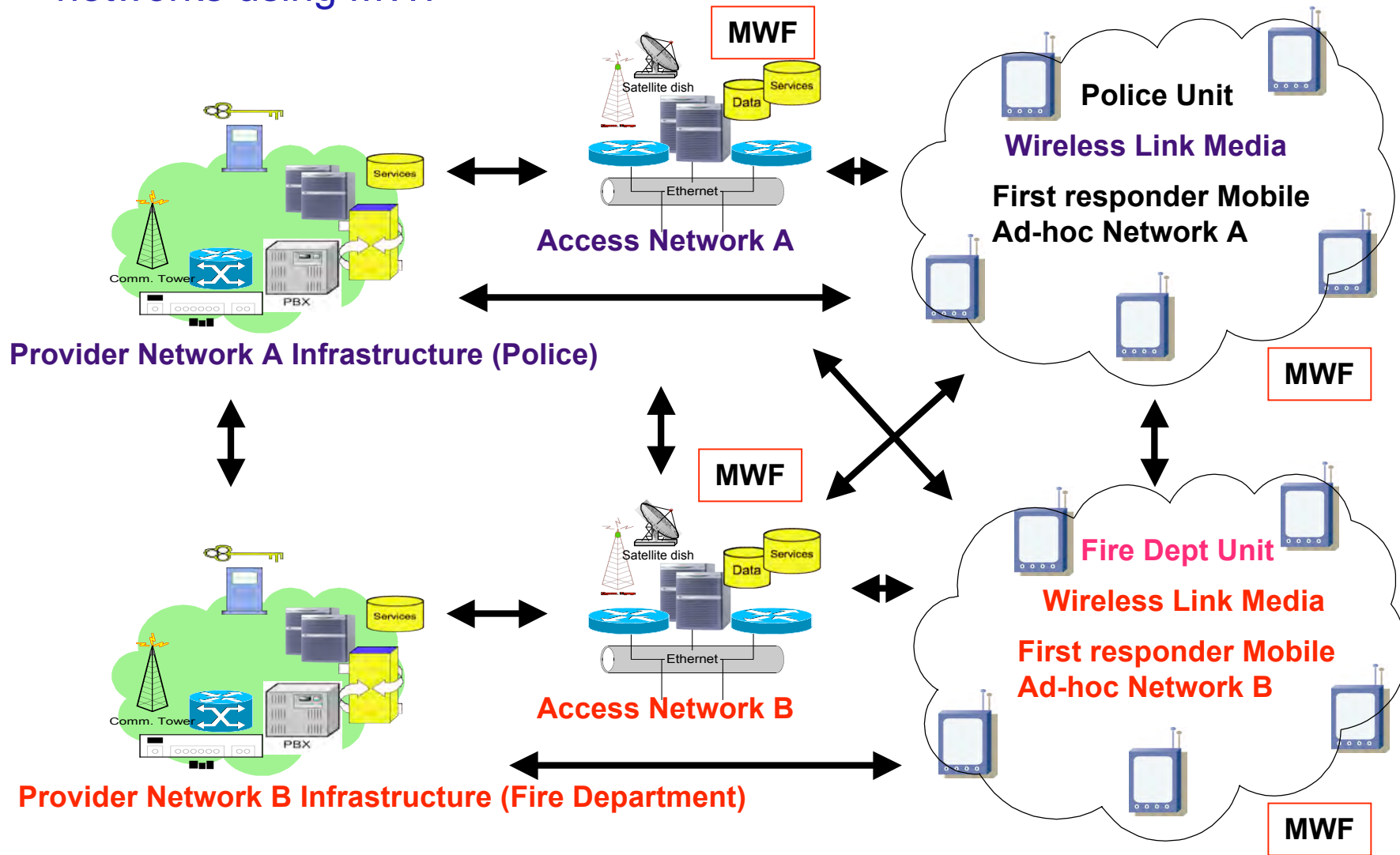



# An Example application from PublicSafety Communication Europe

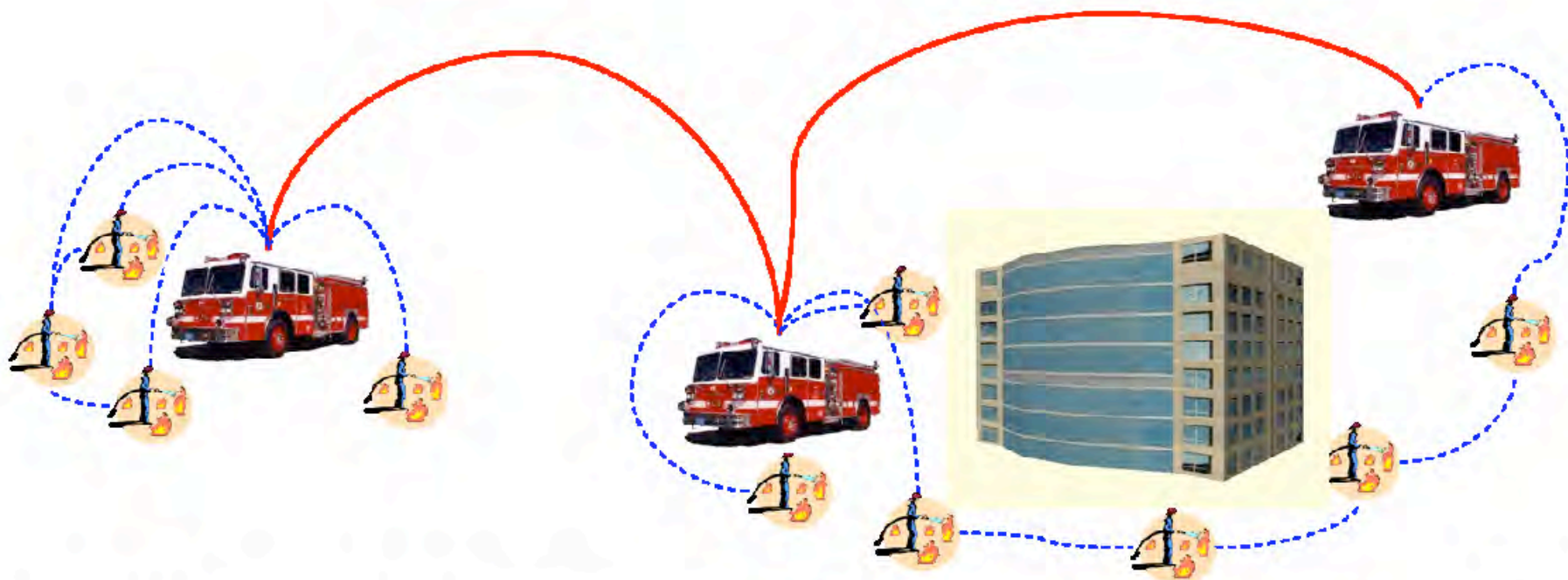

**Figure 15 – An example application of multi-level routing: the fire trucks have better equipment and form a backbone network**

# Military Fast Deployed & Mobile Networks

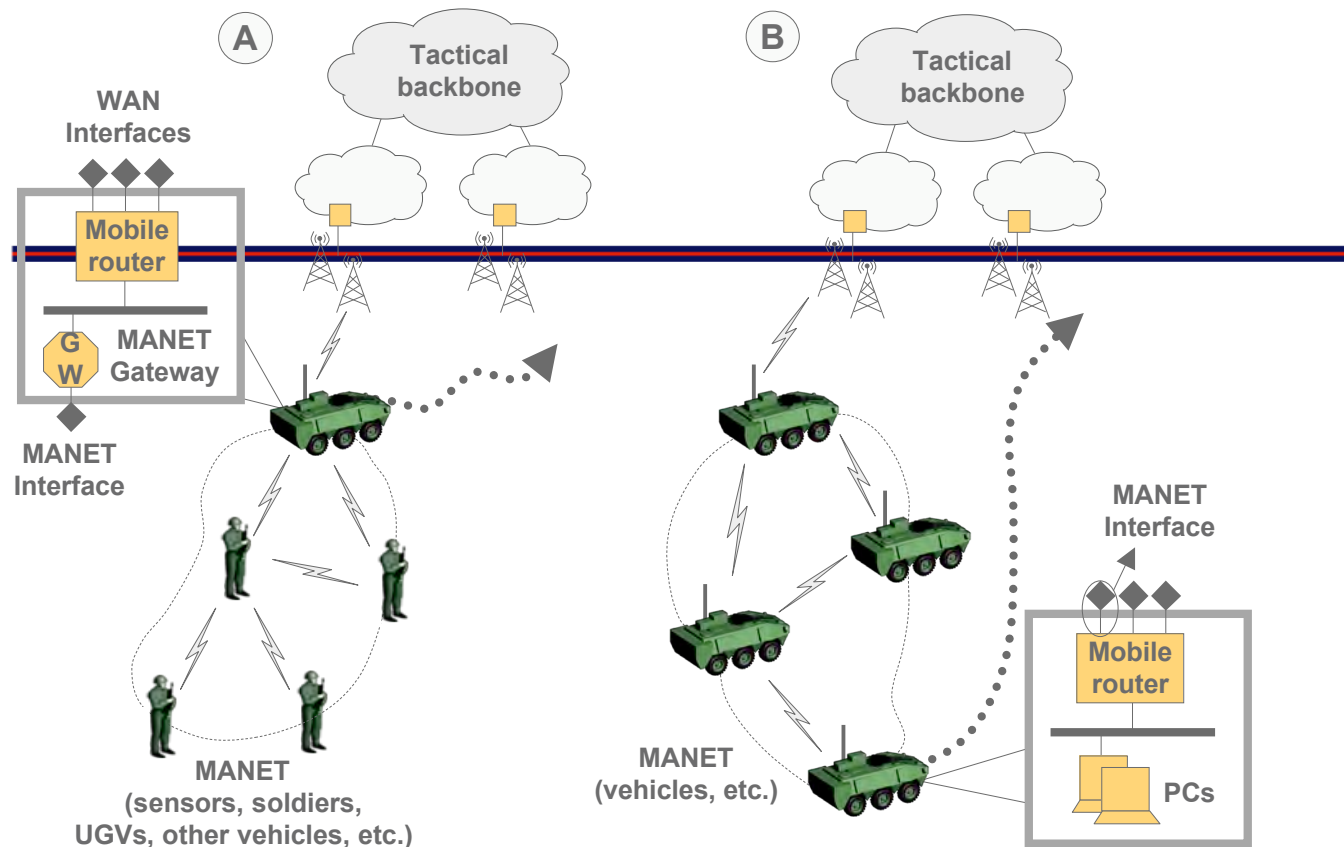

Source: <http://insc.nodeca.mil.no/>

- INSC: Interoperable Networks for Secure Communications
- 8 NATO members R&D effort: CA/FR/GE/IT/NL/NO/UK/US

# What is MANEMO?

MANEMO provides the necessary additions to existing protocols (IPv6, ND, NEMO), for nested Mobile Routers to find the most suited exit towards the infrastructure. MANEMO enables some internal connectivity within the nested NEMO whether the infrastructure is reachable or not.\*

\* **draft-wakikawa-manemo-problem-statement-00.txt**

# MANEMO requires

- Formatting the nested NEMO
  - Into a Loopless Logical Topology
  - Oriented towards the “nearest” Exit Router
- Internal routing in nested NEMO
  - Routing Scope depends on bandwidth and stability
  - Routing decision via the infrastructure vs. within MANET
- Managing multicast within nested NEMO
  - Seamless support of inner movement
  - MLD proxy type of interaction with the infrastructure
  - Inner default rendezvous point when not connected to infrastructure

# MANEMO assumptions

- Internet reachability is the highest requirement
  - as opposed to the routing inside the nested NEMO
- Each Mobile Router has own prefix
  - assigned by NEMO
  - Nodes form temporary addresses from MNP
  - => no renumbering due to movements
- Radio resources are scarce
  - Infrastructure has relatively huge bandwidth
  - using infrastructure unless close neighborhood

# NEMO RO PS

- Seven problems listed in draft-ietf-nemo-ro-problem-statement-03.txt
  - 2. NEMO Route Optimization Problem Statement
    - 2.1. Sub-Optimality with NEMO Basic Support
    - 2.2. Bottleneck in Home Network
    - **2.3. Amplified Sub-Optimality in Nested Mobile Networks (pinball effect)**
    - 2.4. Sub-Optimality with Combined Mobile IPv6 Route Optimization
    - 2.5. Security Policy Prohibiting Traffic From Visiting Nodes
    - **2.6. Instability of Communications within a Nested Mobile Network (Loss of global connectivity prevents neighborhood communications)**
    - **2.7. Stalemate with a Home Agent Nested in a Mobile Network (HA behind MR)**

# Nested NEMO operations

- Exit router discovery
- Loopless attachment router selection
- E2I routing
  - Along the loopless topology
- E2E routing
  - Line of sight
  - One hop away
  - Routed (MANET)

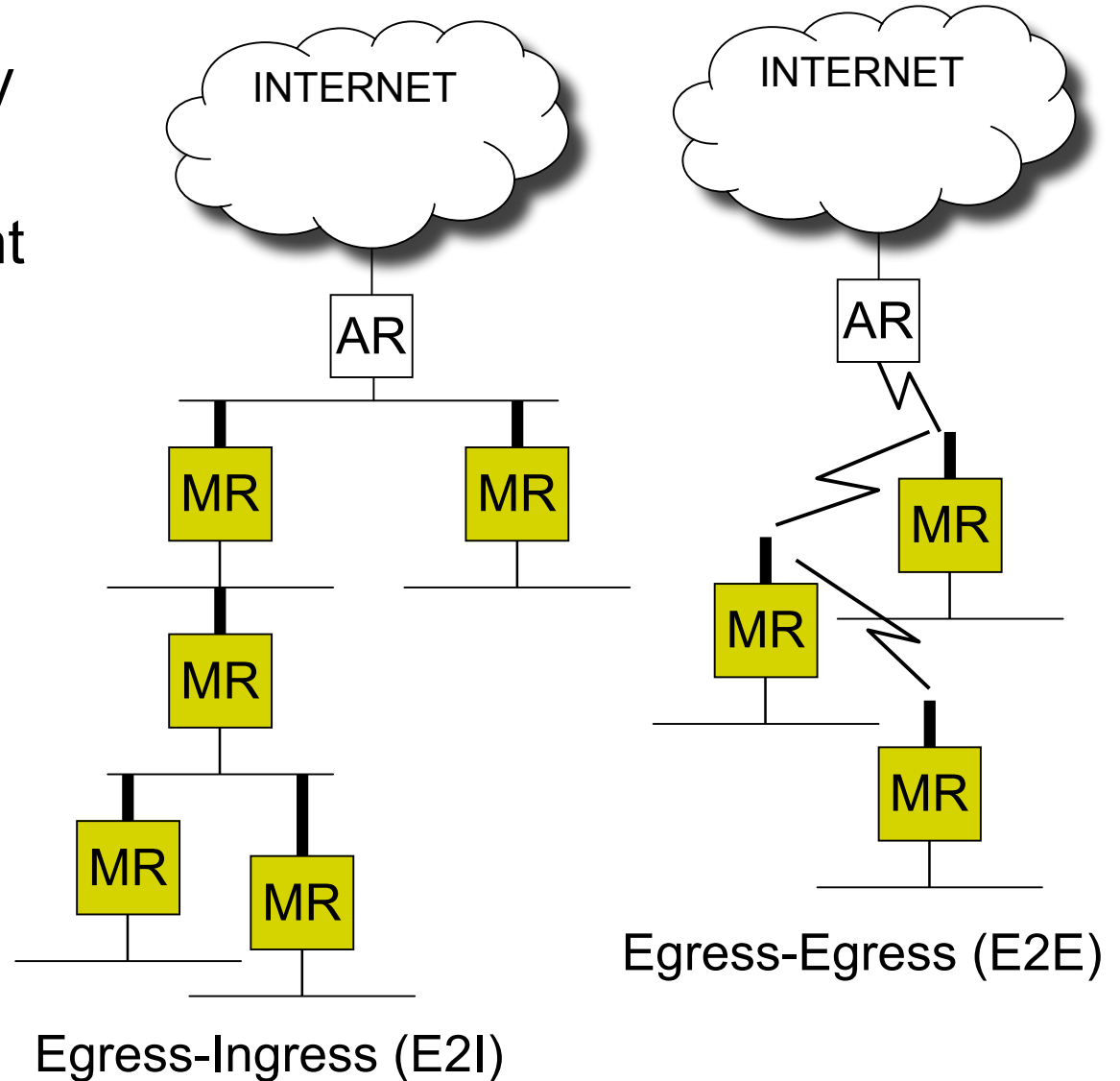

# Optimized Path inside Nested NEMO

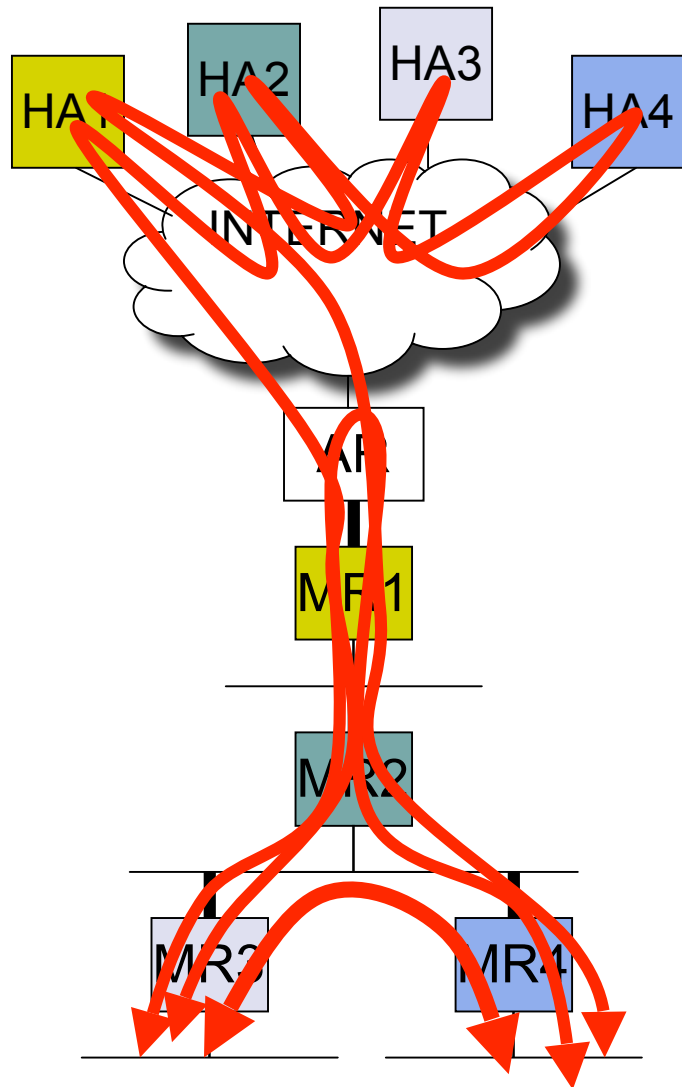

- The Path From MR1 to MR4
  - MR1->AR->HA1->HA4->HA2->HA1->AR->MR1->MR2->MR4
- The Path from MR3 to MR4
  - MR3->MR2->MR1->AR->HA1->HA2->HA3->HA4->HA2->HA1->AR->MR1->MR2->MR4
- **This may be out of scope in NEMO WG**
  - *A mechanism to exchange "Mobile Network Prefix" inside a nested NEMO and to provide certain optimized path.*



# Optimized Path from Nested NEMO to the Internet (vice versa)

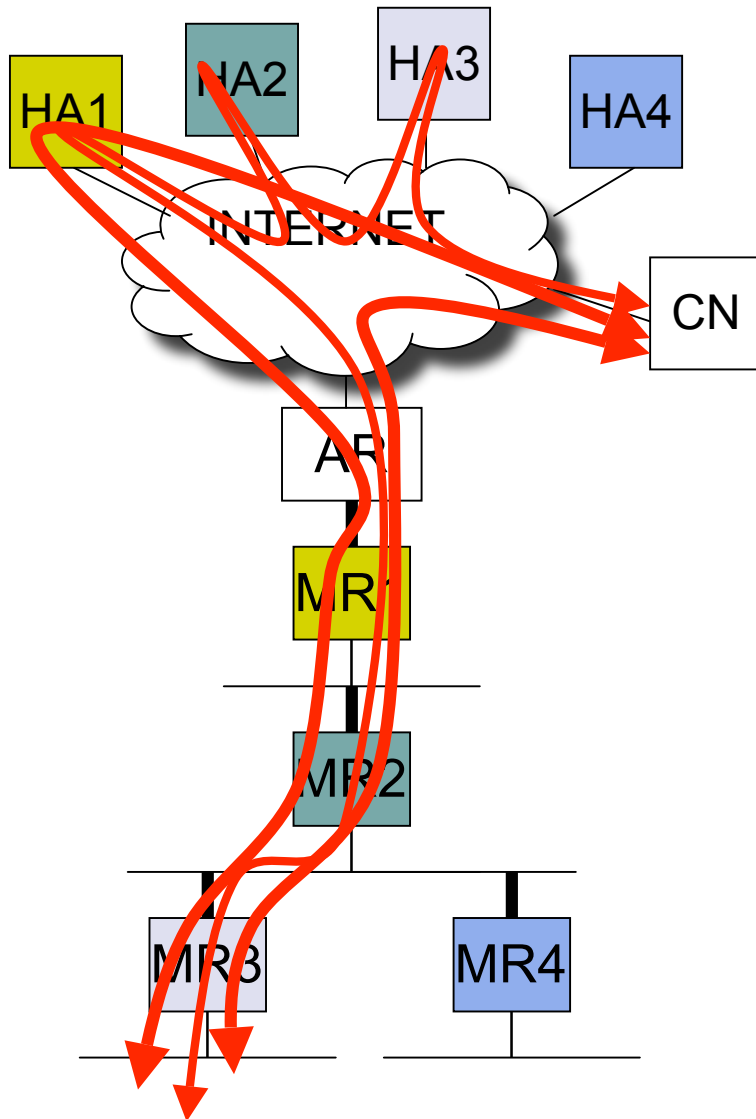

- **This should be addressed in NEMO WG**
- *A mechanism to route packets over nested NEMO without multiple IP encapsulations and ping-pong routing among HAs.*

# Egress-Egress connection

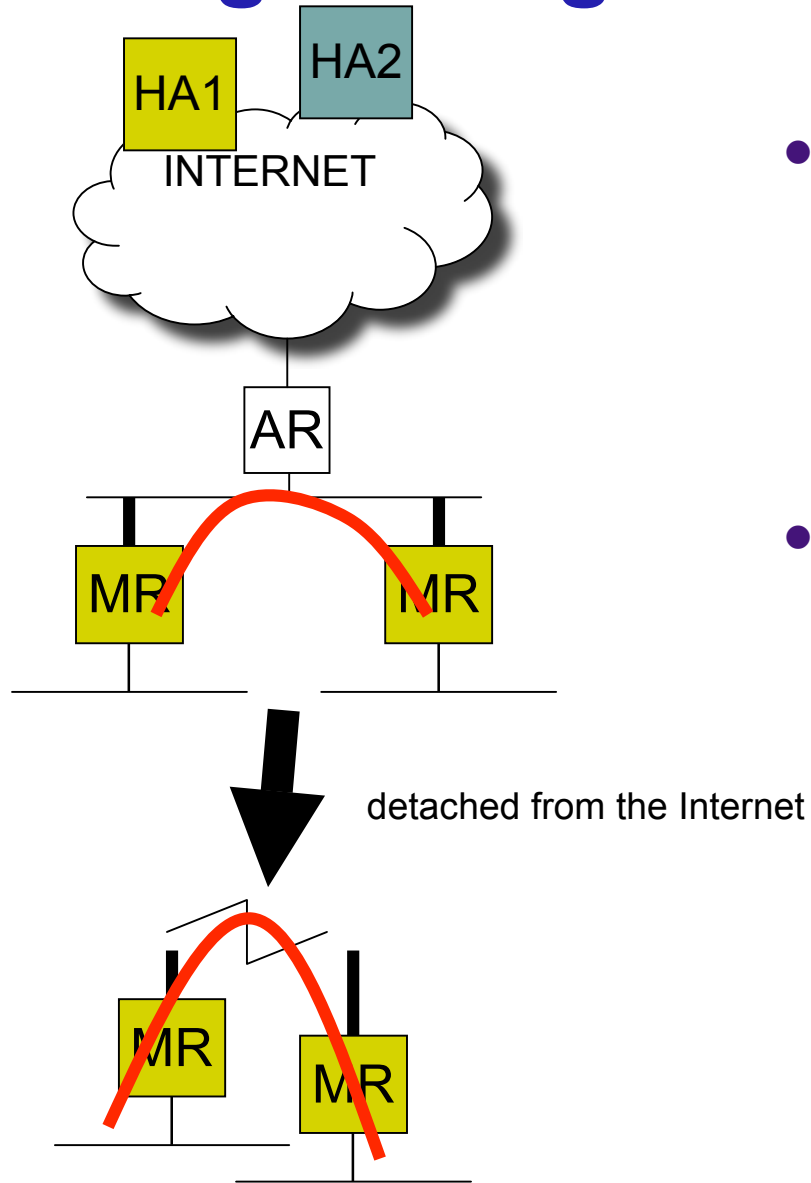

- Communication capability between nearby MRs
  - without Internet reachability
  - without HA involvement
- NEMO scope or maybe not
  - depending on topology of MRs
    - multi-hop?
    - one hop?

# Exit Router Discovery

- Attaching node is unaware of mobility and reachability to the Internet.
  - Mobile Network is seen as an IPv6 link.
  - Since this is NEMO, a mobile network is not always reachable to the Internet due to movements.
- Clarification
  - NEMO scope.
    - Need an mechanism to know the reachability and an exit router(s) to the Internet.
  - Not NEMO scope.
    - forming a nested NEMO without loop in logical fashion
    - maintaining a route between an exit router and each MR

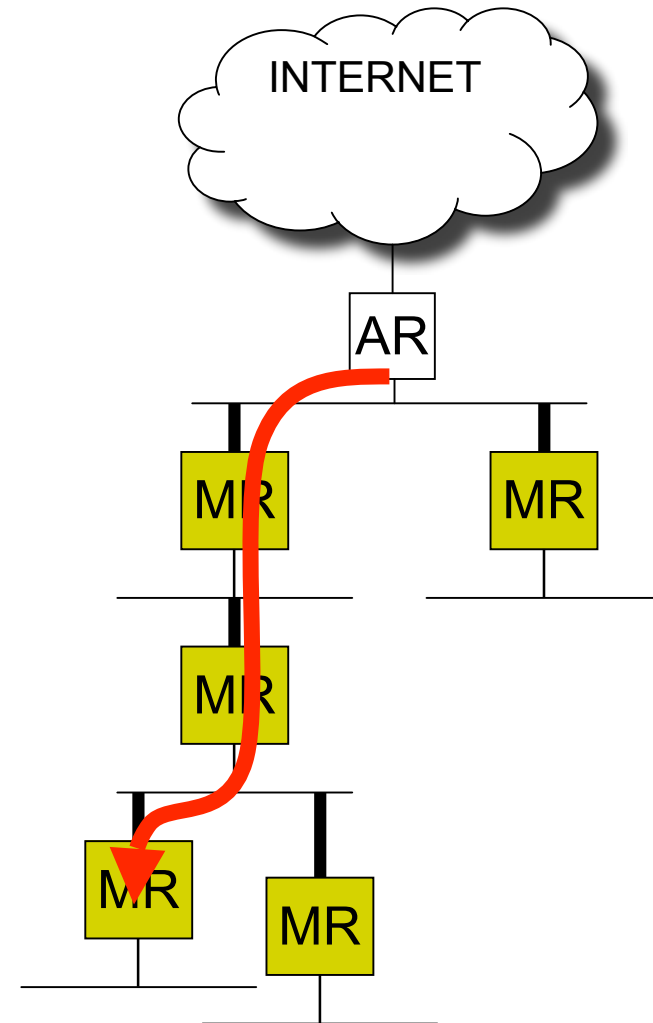

# More info

- MANEMO Web
  - document lists, agenda for pre-BOFs, ML information

**<http://www.mobileip.jp/MANEMO/>**

- ***Pre BOF Thursday 19:30- 21:00 in Tyrolka.***

- Contact address:
  - Ryuji ryuji@sfc.wide.ad.jp
  - Teco teco@inf-net.nl
  - Bryan brmclaug@cisco.com
  - Pascal pthubert@cisco.com

# Related drafts

- ✓ [draft-wakikawa-manemo-problem-statement-00.txt](#)
- ✓ [draft-clausen-nemo-ro-problem-statement-01.txt](#)
- ✓ [draft-boot-manet-nemo-analysis-00.txt](#)
- ✓ [draft-baldessari-c2ccc-nemo-req-00.txt](#)
- ✓ [draft-chakrabarti-mobopts-lowpan-req-01.txt](#)
- ✓ [draft-ietf-nemo-ro-space-analysis-03.txt](#)
- ✓ [draft-ietf-nemo-ro-problem-statement-03.txt](#)
- ✓ [draft-ietf-autoconf-manetarch-01](#)
- ✓ [draft-thubert-tree-discovery-04.txt](#)
- ✓ [draft-thubert-nina-00.txt](#)
- ✓ [draft-petrescu-manemo-nano-00.txt](#)
- ✓ [draft-thubert-nemo-reverse-routing-header-07.txt](#)
- ✓ [draft-templin-autoconf-dhcp-05.txt](#)

# Q&A