

drip
Internet-Draft
Intended status: Informational
Expires: August 26, 2021

S. Card
A. Wiethuechter
AX Enterprize
R. Moskowitz
HTT Consulting
S. Zhao (Editor)
Tencent
A. Gurtov
Linkoeping University
February 22, 2021

Drone Remote Identification Protocol (DRIP) Architecture
draft-ietf-drip-arch-10

Abstract

This document defines an architecture for protocols and services to support Unmanned Aircraft System Remote Identification and tracking (UAS RID), plus RID-related communications, including required architectural building blocks and their interfaces.

Status of This Memo

This Internet-Draft is submitted in full conformance with the provisions of BCP 78 and BCP 79.

Internet-Drafts are working documents of the Internet Engineering Task Force (IETF). Note that other groups may also distribute working documents as Internet-Drafts. The list of current Internet-Drafts is at <https://datatracker.ietf.org/drafts/current/>.

Internet-Drafts are draft documents valid for a maximum of six months and may be updated, replaced, or obsoleted by other documents at any time. It is inappropriate to use Internet-Drafts as reference material or to cite them other than as "work in progress."

This Internet-Draft will expire on August 26, 2021.

Copyright Notice

Copyright (c) 2021 IETF Trust and the persons identified as the document authors. All rights reserved.

This document is subject to BCP 78 and the IETF Trust's Legal Provisions Relating to IETF Documents (<https://trustee.ietf.org/license-info>) in effect on the date of publication of this document. Please review these documents

carefully, as they describe your rights and restrictions with respect to this document. Code Components extracted from this document must include Simplified BSD License text as described in Section 4.e of the Trust Legal Provisions and are provided without warranty as described in the Simplified BSD License.

Table of Contents

1.	Introduction	3
1.1.	Overview UAS Remote ID (RID) and RID Standardization	3
1.2.	Overview of Types of UAS Remote ID	4
1.2.1.	Broadcast RID	4
1.2.2.	Network RID	4
1.3.	Overview of USS Interoperability	6
1.4.	Overview of DRIP Architecture	6
2.	Conventions	8
3.	Definitions and Abbreviations	8
3.1.	Additional Definitions	8
3.2.	Abbreviations	8
3.3.	Claims, Assertions, Attestations, and Certificates	9
4.	HHIT for DRIP Entity Identifier	10
4.1.	UAS Remote Identifiers Problem Space	10
4.2.	HIT as A Trustworthy DRIP Entity Identifier	11
4.3.	HHIT for DRIP Identifier Registration and Lookup	11
4.4.	HHIT for DRIP Identifier Cryptographic	12
5.	DRIP Identifier Registration and Registries	12
5.1.	Public Information Registry	13
5.1.1.	Background	13
5.1.2.	Proposed Approach	13
5.2.	Private Information Registry	13
5.2.1.	Background	13
5.2.2.	Proposed Approach	14
6.	Harvesting Broadcast Remote ID messages for UTM Inclusion	14
6.1.	The CS-RID Finder	15
6.2.	The CS-RID SDSP	15
7.	Privacy for Broadcast PII	15
8.	Security Considerations	16
9.	Acknowledgements	16
10.	References	16
10.1.	Normative References	16
10.2.	Informative References	17
Appendix A.	Overview of Unmanned Aircraft Systems (UAS) Traffic Management (UTM)	19
A.1.	Operation Concept	19
A.2.	UAS Service Supplier (USS)	19
A.3.	UTM Use Cases for UAS Operations	20
A.4.	Automatic Dependent Surveillance Broadcast (ADS-B)	20
Authors' Addresses		21

1. Introduction

This document describes an architecture for protocols and services to support Unmanned Aircraft System Remote Identification and tracking (UAS RID), plus RID-related communications, conforming to proposed and final regulations plus external technical standards, satisfying the requirements listed in the companion requirements document [I-D.ietf-drip-reqs].

1.1. Overview UAS Remote ID (RID) and RID Standardization

UAS Remote Identification (RID) is an application enabler for a UAS to be identified by UTM/USS or third parties entities such as law enforcement. Many safety and other considerations dictate that UAS be remotely identifiable. CAAs worldwide are mandating UAS RID. The European Union Aviation Safety Agency (EASA) has published [Delegated] and [Implementing] Regulations.

CAAs currently promulgate performance-based regulations that do not specify techniques, but rather cite industry consensus technical standards as acceptable means of compliance.

FAA

The FAA published a Notice of Proposed Rule Making [NPRM] in 2019 and whereafter published the Final Rule [FAA_RID] in 2021.

ASTM

ASTM International, Technical Committee F38 (UAS), Subcommittee F38.02 (Aircraft Operations), Work Item WK65041, developed the ASTM [F3411-19] Standard Specification for Remote ID and Tracking.

ASTM defines one set of RID information and two means, MAC-layer broadcast and IP-layer network, of communicating it. If a UAS uses both communication methods, the same information must be provided via both means. The [F3411-19] is cited by FAA in its RID final rule [FAA_RID] as "a potential means of compliance" to a Remote ID rule.

3GPP

With release 16, 3GPP completed the UAS RID requirement study [TS-22.825] and proposed use cases in the mobile network and the services that can be offered based on RID. Release 17 specification works on enhanced UAS service requirements and provides the protocol and application architecture support which is applicable for both 4G and 5G network.

1.2. Overview of Types of UAS Remote ID

1.2.1. Broadcast RID

A set of RID messages are defined for direct, one-way, broadcast transmissions from the UA over Bluetooth or Wi-Fi. These are currently defined as MAC-Layer messages. Internet (or other Wide Area Network) connectivity is only needed for UAS registry information lookup by Observers using the locally directly received UAS RID as a key. Broadcast RID should be functionally usable in situations with no Internet connectivity.

The Broadcast RID is illustrated in Figure 1 below.

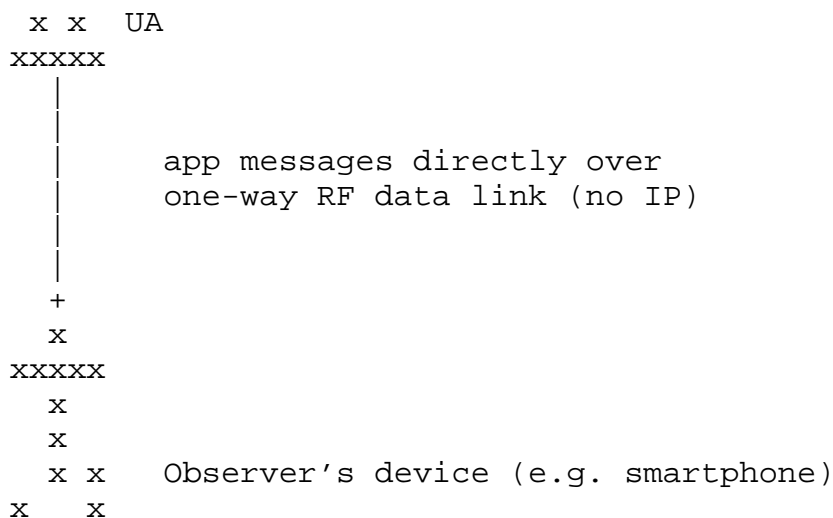

Figure 1

With Broadcast RID, an Observer is limited to their radio "visible" airspace for UAS awareness and information. With Internet queries using harvested RID (see Section 6), the Observer may gain more information about those visible UAS.

1.2.2. Network RID

A RID data dictionary and data flow for Network RID are defined in [F3411-19]. This data flow is from a UAS via unspecified means (but at least in part over the Internet) to a Network Remote ID Service Provider (Net-RID SP). These Net-RID SPs provide the RID data to Network Remote ID Display Providers (Net-RID DP). It is the Net-RID DP that responds to queries from Network Remote ID Observers (expected typically, but not specified exclusively, to be web-based) specifying airspace volumes of interest. Network RID depends upon

connectivity, in several segments, via the Internet, from the UAS to the Observer.

The Network RID is illustrated in Figure 2 below:

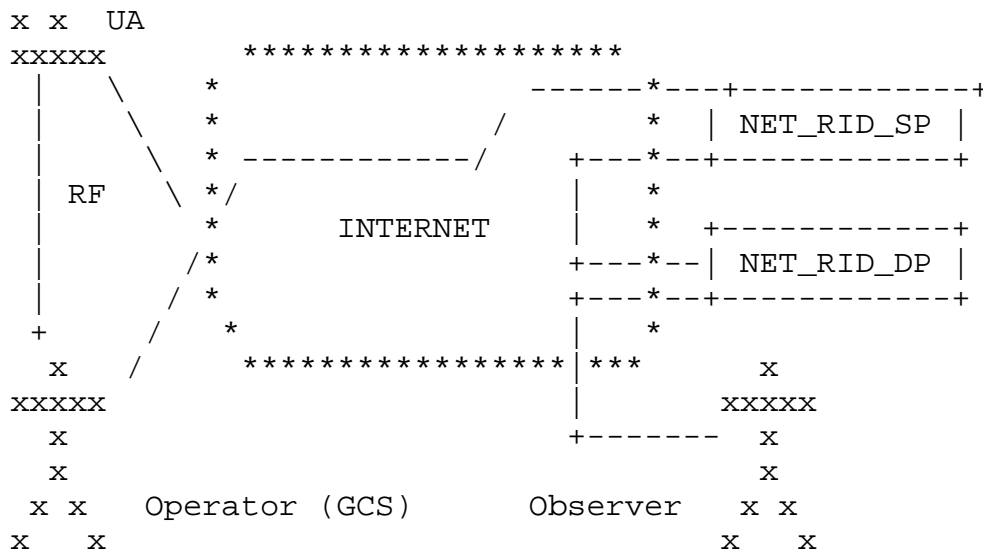

Figure 2

Command and Control (C2) must flow from the GCS to the UA via some path (ex. a direct RF link, but with increasing BVLOS operations expected often to be wireless links at either end with the Internet between). For all but the simplest hobby aircraft, telemetry (at least position and heading) flows from the UA to the GCS via some path (typically the reverse of the C2 path). Thus RID information pertaining to both the GCS and the UA can be sent by whichever has Internet connectivity to the Net-RID SP (typically the USS managing the UAS operation). The Net-RID SP forwards RID information via the Internet to subscribed Net-RID DP (typically other USS). Subscribed Net-RID DP forward RID information via the Internet to subscribed Observer devices. Regulations require and [F3411-19] describes RID data elements end-to-end. [F3411-19] prescribes the protocol only among Net-RID SP, Net-RID DP, and the Discovery and Synchronization Service (DSS).

Informative note: Neither link layer protocols nor the use of links (e.g., the link often existing between the GCS and the UA) for any purpose other than carriage of RID information is in the scope of [F3411-19] Network RID..

1.3. Overview of USS Interoperability

Each UAS is registered to at least one USS. With Net-RID, there is direct communication between the UAS and its USS. With Broadcast-RID, the UAS Operator has either pre-filed a 4D space volume for USS operational knowledge and/or Observers can be providing information about observed UA to a USS. USS exchange information via a Discovery and Synchronization Service (DSS) so all USS collectively have knowledge about all activities in a 4D airspace.

The interactions among Observer, UA, and USS are shown in Figure 3.

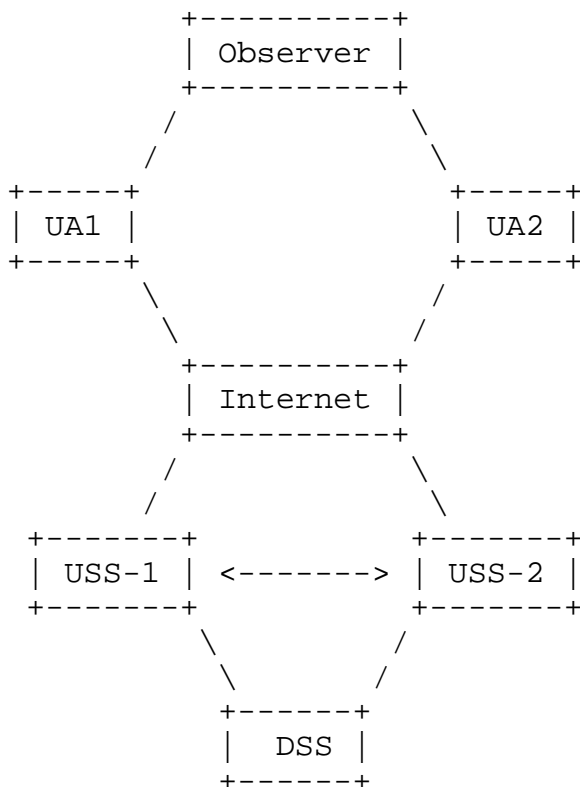

Figure 3

1.4. Overview of DRIP Architecture

The requirements document [I-D.ietf-drip-reqs] also provides an extended introduction to the problem space, use cases, etc. Only a brief summary of that introduction will be restated here as context, with reference to the general UAS RID usage scenarios shown in Figure 4 below.

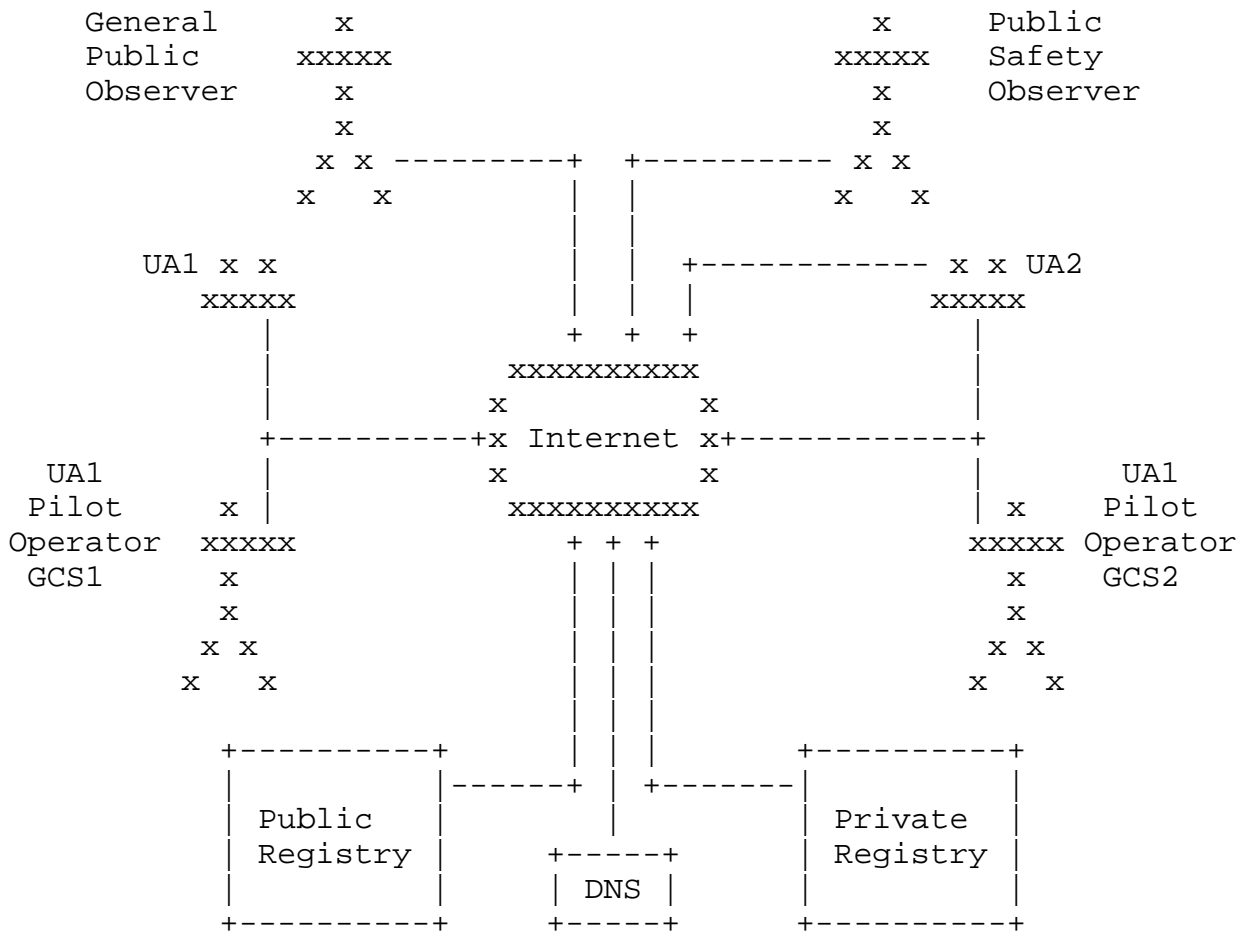

Figure 4

DRIP will enable leveraging existing Internet resources (standard protocols, services, infrastructure, and business models) to meet UAS RID and closely related needs. DRIP will specify how to apply IETF standards, complementing [F3411-19] and other external standards, to satisfy UAS RID requirements. DRIP will update existing and develop new protocol standards as needed to accomplish the foregoing.

This document will outline the UAS RID architecture into which DRIP must fit and the architecture for DRIP itself. This includes presenting the gaps between the CAAs' Concepts of Operations and [F3411-19] as it relates to the use of Internet technologies and UA direct RF communications. Issues include, but are not limited to:

- * Design of trustworthy remote ID and trust in RID messages (Section 4)

- * Mechanisms to leverage Domain Name System (DNS: [RFC1034]), Extensible Provisioning Protocol (EPP [RFC5731]) and Registration Data Access Protocol (RDAP) ([RFC7482]) to provide for private (Section 5.2) and public (Section 5.1) Information Registry.

- * Harvesting broadcast remote ID messages for UTM inclusion (Section 6)

- * Privacy in RID messages (PII protection) (Section 7)

2. Conventions

The key words "MUST", "MUST NOT", "REQUIRED", "SHALL", "SHALL NOT", "SHOULD", "SHOULD NOT", "RECOMMENDED", "NOT RECOMMENDED", "MAY", and "OPTIONAL" in this document are to be interpreted as described in BCP 14 [RFC2119] [RFC8174] when, and only when, they appear in all capitals, as shown above.

3. Definitions and Abbreviations

3.1. Additional Definitions

This document uses terms defined in [I-D.ietf-drip-reqs].

3.2. Abbreviations

ADS-B:	Automatic Dependent Surveillance Broadcast
DSS:	Discovery & Synchronization Service
EdDSA:	Edwards-Curve Digital Signature Algorithm
GCS:	Ground Control Station
HHIT:	Hierarchical HIT Registries
HIP:	Host Identity Protocol
HIT:	Host Identity Tag
RID:	Remote ID
Net-RID SP:	Network RID Service Provider

Net-RID DP: Network RID Display Provider.

PII: Personally Identifiable Information

RF: Radio Frequency

SDSP: Supplemental Data Service Provider

UA: Unmanned Aircraft

UAS: Unmanned Aircraft System

USS: UAS Service Supplier

UTM: UAS Traffic Management

3.3. Claims, Assertions, Attestations, and Certificates

This section introduces the meaning of "Claims", "Assertions", "Attestations", and "Certificates" in the context of DRIP.

This is due to the term "certificate" having significant technologic and legal baggage associated with it, specifically around X.509 certificates. These type of certificates and Public Key Infrastructure invokes more legal and public policy considerations than probably any other electronic communication sector. It emerged as a governmental platform for trusted identity management and was pursued in intergovernmental bodies with links into treaty instruments.

Claims:

For DRIP claims are used in the form of a predicate (X is Y, X has property Y, and most importantly X owns Y). One basic use case of a claim is an entity using a HHIT as an identifier in the DRIP UAS system.

Assertions:

Assertions, under DRIP, are defined as being a set of one or more claims. This definition is borrowed from JWT/CWT. An HHIT in of itself can be seen as a set of assertion. First that the identifier is a handle to an asymmetric keypair owned by the entity and that it also is part of the given registry (specified by the HID).

Attestations:

An attestation is a signed claim. The signee may be the claimant themselves or a third party. Under DRIP this is normally used when a set of entities asserts a relationship between them along with other information.

Certificates:

Certificates in DRIP have a narrow definition of being signed exclusively by a third party and are only over identities.

4. HHIT for DRIP Entity Identifier

This section describes the basic requirements of a DRIP entity identifier per regulation constrains from ASTM [F3411-19] and explains the use of Hierarchical Host Identity Tags (HHITs) as self-asserting IPv6 addresses and thereby a trustable DRIP identifier for use as the UAS Remote ID. HHITs self-attest to the included explicit hierarchy that provides Registrar discovery for 3rd-party ID attestation.

4.1. UAS Remote Identifiers Problem Space

A DRIP entity identifier needs to be "Trustworthy". This means that within the framework of the RID messages, an Observer can establish that the DRIP identifier used does uniquely belong to the UAS. That the only way for any other UAS to assert this DRIP identifier would be to steal something from within the UAS. The DRIP identifier is self-generated by the UAS (either UA or GCS) and registered with the USS.

The data communication of using Broadcast RID faces extreme challenges due to the limitation of the demanding support for Bluetooth. The ASTM [F3411-19] defines the basic RID message which is expected to contain certain RID data and the Authentication message. The Basic RID message has a maximum payload of 25 bytes and the maximum size allocated by ASTM for the RID is 20 bytes and only 3 bytes are left unused. currently, the authentication maximum payload is defined to be 201 bytes.

Standard approaches like X.509 and PKI will not fit these constraints, even using the new EdDSA [RFC8032] algorithm. An example of a technology that will fit within these limitations is an enhancement of the Host Identity Tag (HIT) of HIPv2 [RFC7401] using Hierarchical HITs (HHITs) for UAS RID is outlined in HHIT based UAS RID [I-D.ietf-drip-rid]. As PKI with X.509 is being used in other systems with which UAS RID must interoperate (e.g. Discovery and Synchronization Service and any other communications involving USS)

mappings between the more flexible but larger X.509 certificates and the HHIT-based structures must be devised.

By using the EdDSA HHIT suite, the self-attestations of the RID can be done in as little as 84 bytes. Third-party Certificates can be done in 200 bytes. An Observer would need Internet access to validate a self-attestations claim. A third-party Certificate can be validated via a small credential cache in a disconnected environment. This third-party Certificate is possible when the third-party also uses HHITs for its identity and the UA has the public key and the Certificate for that HHIT.

4.2. HIT as A Trustworthy DRIP Entity Identifier

For a Remote ID to be trustworthy in the Broadcast mode, it is better to have an asymmetric keypair for proof of ID ownership. The common method of using a key signing operation to assert ownership of an ID, does not guarantee name uniqueness. Any entity can sign an ID, claiming ownership. To mitigate spoofing risks, the ID needs to be cryptographically generated from the public key, in such a manner that it is statistically hard for an entity to create a public key that would generate (spoof) the ID. Thus the signing of such an ID becomes an a proof (verifiable attestation, versus mere claim) of ownership.

HITs are statistically unique through the cryptographic hash feature of second-preimage resistance. The cryptographically-bound addition of the Hierarchy and a HHIT registration process (e.g. based on Extensible Provisioning Protocol, [RFC5730]) provide complete, global HHIT uniqueness. This is in contrast to general IDs (e.g. a UUID or device serial number) as the subject in an X.509 certificate.

4.3. HHIT for DRIP Identifier Registration and Lookup

DRIP identifiers need a deterministic lookup mechanism that rapidly provides actionable information about the identified UA. The identifier itself needs to be the inquiry input into the lookup given the constraints imposed by some of the broadcast media. This can best be achieved by an Identifier registration hierarchy cryptographically embedded within the Identifier.

A HHIT itself consists of a registration hierarchy, the hashing crypto suite information, and the hash of these items along with the underlying public key. Additional information, e.g. an IPv6 prefix, can enhance the HHITs use beyond the basic Remote ID function (e.g. use in HIP, [RFC7401]).

Therefore, a DRIP identifier can be represented as a HHIT.

It can be self-generated by a UAS (either UA or GCS) and registered with the Private Information Registry (More details in Section 5.2) identified in its hierarchy fields. Each DRIP identifier represented as a HHIT can not be used more than once.

A DRIP identifier can be assigned to a UAS as a static HHIT by its manufacturer, such as a single HI and derived HHIT encoded as a hardware serial number per [CTA2063A]. Such a static HHIT can only be used to bind one-time use DRIP identifiers to the unique UA. Depending upon implementation, this may leave a HI private key in the possession of the manufacturer (more details in Section 8).

In another case, a UAS equipped for Broadcast RID can be provisioned not only with its HHIT but also with the HI public key from which the HHIT was derived and the corresponding private key, to enable message signature. A UAS equipped for Network RID can be provisioned likewise; the private key resides only in the ultimate source of Network RID messages (i.e. on the UA itself if the GCS is merely relaying rather than sourcing Network RID messages). Each Observer device can be provisioned either with public keys of the DRIP identifier root registries or certificates for subordinate registries.

The Operators, Private Information Registries as well as other UTM entities can possess UAS ID style HHITs. When present, such HHITs can be used with HIP to strongly mutually authenticate and optionally encrypt communications.

4.4. HHIT for DRIP Identifier Cryptographic

The only (known to the authors of this document at the time of its writing) extant fixed-length ID cryptographically derived from a public key are the Host Identity Tag [RFC7401], HITs, and Cryptographically Generated Addresses [RFC3972], CGAs. However, both HITs and CGAs lack registration/retrieval capability. HHIT, on the other hand, is capable of providing a cryptographic hashing function, along with a registration process to mitigate the probability of a hash collision (first registered, first allowed).

5. DRIP Identifier Registration and Registries

UAS registries can hold both public and private UAS information resulting from the DRIP identifier registration process. Given these different uses, and to improve scalability, security, and simplicity of administration, the public and private information can be stored in different registries. A DRIP identifier is amenable to handling as an Internet domain name (at an arbitrary level in the hierarchy). It also can be registered in at least a pseudo-domain (e.g. .ip6.arpa

for reverse lookup), or as a sub-domain (for forward lookup). This section introduces the public and private information registries for DRIP identifiers.

5.1. Public Information Registry

5.1.1. Background

The public registry provides trustable information such as attestations of RID ownership and HDA registration. Optionally, pointers to the repositories for the HDA and RAA implicit in the RID can be included (e.g. for HDA and RAA HHIT|HI used in attestation signing operations). This public information will be principally used by Observers of Broadcast RID messages. Data on UAS that only use Network RID, is only available via an Observer's Net-RID DP that would tend to provide all public registry information directly. The Observer can visually "see" these UAS, but they are silent to the Observer; the Net-RID DP is the only source of information based on a query for an airspace volume.

5.1.2. Proposed Approach

A DRIP public information registry can respond to standard DNS queries, in the definitive public Internet DNS hierarchy. If a DRIP public information registry lists, in a HIP RR, any HIP RVS servers for a given DRIP identifier, those RVS servers can restrict relay services per AAA policy; this requires extensions to [RFC8004]. These public information registries can use secure DNS transport (e.g. DNS over TLS) to deliver public information that is not inherently trustable (e.g. everything other than attestations).

5.2. Private Information Registry

5.2.1. Background

The private information required for DRIP identifiers is similar to that required for Internet domain name registration. A DRIP identifier solution can leverage existing Internet resources: registration protocols, infrastructure and business models, by fitting into an ID structure compatible with DNS names. This implies some sort of hierarchy, for scalability, and management of this hierarchy. It is expected that the private registry function will be provided by the same organizations that run USS, and likely integrated with USS.

5.2.2. Proposed Approach

A DRIP private information registry can support essential Internet domain name registry operations (e.g. add, delete, update, query) using interoperable open standard protocols. It can also support the Extensible Provisioning Protocol (EPP) and the Registry Data Access Protocol (RDAP) with access controls.

It might be listed in a DNS: that DNS could be private; but absent any compelling reasons for use of private DNS, a public DNS hierarchy needs to be in place. The DRIP private information registry in which a given UAS is registered needs to be findable, starting from the UAS ID, using the methods specified in [RFC7484]. A DRIP private information registry can also support WebFinger as specified in [RFC7033].

6. Harvesting Broadcast Remote ID messages for UTM Inclusion

ASTM anticipated that regulators would require both Broadcast RID and Network RID for large UAS, but allow RID requirements for small UAS to be satisfied with the operator's choice of either Broadcast RID or Network RID. The EASA initially specified Broadcast RID for UAS of essentially all UAS and is now also considering Network RID. The FAA RID Final Rules only specifies Broadcast RID for UAS, however, still encourages Network RID for complementary functionality, especially in support of UTM.

One obvious opportunity is to enhance the architecture with gateways from Broadcast RID to Network RID. This provides the best of both and gives regulators and operators flexibility. It offers considerable enhancement over some Network RID options such as only reporting planned 4D operation space by the operator.

These gateways could be pre-positioned (e.g. around airports, public gatherings, and other sensitive areas) and/or crowd-sourced (as nothing more than a smartphone with a suitable app is needed). As Broadcast RID media have limited range, gateways receiving messages claiming locations far from the gateway can alert authorities or a SDSP to the failed sanity check possibly indicating intent to deceive. Surveillance SDSPs can use messages with precise date/time/position stamps from the gateways to multilaterate UA location, independent of the locations claimed in the messages (which may have a natural time lag as it is), which are entirely operator self-reported in UAS RID and UTM.

Further, gateways with additional sensors (e.g. smartphones with cameras) can provide independent information on the UA type and size, confirming or refuting those claims made in the RID messages. This Crowd Sourced Remote ID (CS-RID) would be a significant enhancement,

beyond baseline DRIP functionality; if implemented, it adds two more entity types.

6.1. The CS-RID Finder

A CS-RID Finder is the gateway for Broadcast Remote ID Messages into the UTM. It performs this gateway function via a CS-RID SDSP. A CS-RID Finder could implement, integrate, or accept outputs from, a Broadcast RID receiver. However, it can not interface directly with a GCS, Net-RID SP, Net-RID DP or Network RID client. It would present a TBD interface to a CS-RID SDSP; this interface needs to be based upon but readily distinguishable from that between a GCS and a Net-RID SP.

6.2. The CS-RID SDSP

A CS-RID SDSP would appear (i.e. present the same interface) to a Net-RID SP as a Net-RID DP. A CS-RID SDSP can not present a standard GCS-facing interface as if it were a Net-RID SP. A CS-RID SDSP would present a TBD interface to a CS-RID Finder; this interface can be based upon but readily distinguishable between a GCS and a Net-RID SP.

7. Privacy for Broadcast PII

Broadcast RID messages can contain PII. A viable architecture for PII protection would be symmetric encryption of the PII using a key known to the UAS and its USS. An authorized Observer could send the encrypted PII along with the UAS ID (to entities such as USS of the Observer, or to the UAS in which the UAS ID is registered if that can be determined from the UAS ID itself or to a Public Safety USS) to get the plaintext. Alternatively, the authorized Observer can receive the key to directly decrypt all future PII content from the UA.

PII can be protected unless the UAS is informed otherwise. This could come from operational instructions to even permit flying in a space/time. It can be special instructions at the start or during an operation. PII protection can not be used if the UAS loses connectivity to the USS. The UAS always has the option to abort the operation if PII protection is disallowed.

An authorized Observer can instruct a UAS via the USS that conditions have changed mandating no PII protection or land the UA (abort the operation).

8. Security Considerations

The security provided by asymmetric cryptographic techniques depends upon protection of the private keys. A manufacturer that embeds a private key in an UA may have retained a copy. A manufacturer whose UA are configured by a closed source application on the GCS which communicates over the Internet with the factory may be sending a copy of a UA or GCS self-generated key back to the factory. Keys may be extracted from a GCS or UA. The RID sender of a small harmless UA (or the entire UA) could be carried by a larger dangerous UA as a "false flag." Compromise of a registry private key could do widespread harm. Key revocation procedures are as yet to be determined. These risks are in addition to those involving Operator key management practices.

9. Acknowledgements

The work of the FAA's UAS Identification and Tracking (UAS ID) Aviation Rulemaking Committee (ARC) is the foundation of later ASTM and proposed IETF DRIP WG efforts. The work of ASTM F38.02 in balancing the interests of diverse stakeholders is essential to the necessary rapid and widespread deployment of UAS RID. IETF volunteers who have contributed to this draft include Amelia Andersdotter and Mohamed Boucadair.

10. References

10.1. Normative References

[I-D.ietf-drip-reqs]

Card, S., Wiethuechter, A., Moskowitz, R., and A. Gurtov, "Drone Remote Identification Protocol (DRIP) Requirements", draft-ietf-drip-reqs-06 (work in progress), November 2020.

[RFC2119] Bradner, S., "Key words for use in RFCs to Indicate Requirement Levels", BCP 14, RFC 2119, DOI 10.17487/RFC2119, March 1997, <<https://www.rfc-editor.org/info/rfc2119>>.

[RFC8174] Leiba, B., "Ambiguity of Uppercase vs Lowercase in RFC 2119 Key Words", BCP 14, RFC 8174, DOI 10.17487/RFC8174, May 2017, <<https://www.rfc-editor.org/info/rfc8174>>.

10.2. Informative References

- [CTA2063A] ANSI, "Small Unmanned Aerial Systems Serial Numbers", 2019.
- [Delegated] European Union Aviation Safety Agency (EASA), "EU Commission Delegated Regulation 2019/945 of 12 March 2019 on unmanned aircraft systems and on third-country operators of unmanned aircraft systems", 2019.
- [F3411-19] ASTM, "Standard Specification for Remote ID and Tracking", 2019.
- [FAA_RID] United States Federal Aviation Administration (FAA), "Remote Identification of Unmanned Aircraft", 2021, <<https://www.govinfo.gov/content/pkg/FR-2021-01-15/pdf/2020-28948.pdf>>.
- [FAA_UAS_Concept_Of_Ops] United States Federal Aviation Administration (FAA), "Unmanned Aircraft System (UAS) Traffic Management (UTM) Concept of Operations (V2.0)", 2020, <https://www.faa.gov/uas/research_development/traffic_management/media/UTM_ConOps_v2.pdf>.
- [I-D.ietf-drip-rid] Moskowitz, R., Card, S., Wiethuechter, A., and A. Gurtov, "UAS Remote ID", draft-ietf-drip-rid-06 (work in progress), December 2020.
- [Implementing] European Union Aviation Safety Agency (EASA), "EU Commission Implementing Regulation 2019/947 of 24 May 2019 on the rules and procedures for the operation of unmanned aircraft", 2019.
- [LAANC] United States Federal Aviation Administration (FAA), "Low Altitude Authorization and Notification Capability", n.d., <https://www.faa.gov/uas/programs_partnerships/data_exchange/>.
- [NPRM] United States Federal Aviation Administration (FAA), "Notice of Proposed Rule Making on Remote Identification of Unmanned Aircraft Systems", 2019.

- [RFC1034] Mockapetris, P., "Domain names - concepts and facilities", STD 13, RFC 1034, DOI 10.17487/RFC1034, November 1987, <<https://www.rfc-editor.org/info/rfc1034>>.
- [RFC3972] Aura, T., "Cryptographically Generated Addresses (CGA)", RFC 3972, DOI 10.17487/RFC3972, March 2005, <<https://www.rfc-editor.org/info/rfc3972>>.
- [RFC5730] Hollenbeck, S., "Extensible Provisioning Protocol (EPP)", STD 69, RFC 5730, DOI 10.17487/RFC5730, August 2009, <<https://www.rfc-editor.org/info/rfc5730>>.
- [RFC5731] Hollenbeck, S., "Extensible Provisioning Protocol (EPP) Domain Name Mapping", STD 69, RFC 5731, DOI 10.17487/RFC5731, August 2009, <<https://www.rfc-editor.org/info/rfc5731>>.
- [RFC7033] Jones, P., Salgueiro, G., Jones, M., and J. Smarr, "WebFinger", RFC 7033, DOI 10.17487/RFC7033, September 2013, <<https://www.rfc-editor.org/info/rfc7033>>.
- [RFC7401] Moskowitz, R., Ed., Heer, T., Jokela, P., and T. Henderson, "Host Identity Protocol Version 2 (HIPv2)", RFC 7401, DOI 10.17487/RFC7401, April 2015, <<https://www.rfc-editor.org/info/rfc7401>>.
- [RFC7482] Newton, A. and S. Hollenbeck, "Registration Data Access Protocol (RDAP) Query Format", RFC 7482, DOI 10.17487/RFC7482, March 2015, <<https://www.rfc-editor.org/info/rfc7482>>.
- [RFC7484] Blanchet, M., "Finding the Authoritative Registration Data (RDAP) Service", RFC 7484, DOI 10.17487/RFC7484, March 2015, <<https://www.rfc-editor.org/info/rfc7484>>.
- [RFC8004] Laganier, J. and L. Eggert, "Host Identity Protocol (HIP) Rendezvous Extension", RFC 8004, DOI 10.17487/RFC8004, October 2016, <<https://www.rfc-editor.org/info/rfc8004>>.
- [RFC8032] Josefsson, S. and I. Liusvaara, "Edwards-Curve Digital Signature Algorithm (EdDSA)", RFC 8032, DOI 10.17487/RFC8032, January 2017, <<https://www.rfc-editor.org/info/rfc8032>>.
- [TS-22.825] 3GPP, "UAS RID requirement study", n.d., <<https://portal.3gpp.org/desktopmodules/Specifications/SpecificationDetails.aspx?specificationId=3527>>.

[U-Space] European Organization for the Safety of Air Navigation (EUROCONTROL), "U-space Concept of Operations", 2019, <<https://www.sesarju.eu/sites/default/files/documents/u-space/CORUS%20ConOps%20vol2.pdf>>.

Appendix A. Overview of Unmanned Aircraft Systems (UAS) Traffic Management (UTM)

A.1. Operation Concept

The National Aeronautics and Space Administration (NASA) and FAAs' effort of integrating UAS's operation into the national airspace system (NAS) leads to the development of the concept of UTM and the ecosystem around it. The UTM concept was initially presented in 2013 and version 2.0 is published in 2020 [FAA_UAS_Concept_Of_Ops].

The eventual development and implementation are conducted by the UTM research transition team which is the joint workforce by FAA and NASA. World efforts took place afterward. The Single European Sky ATM Research (SESAR) started the CORUS project to research its UTM counterpart concept, namely [U-Space]. This effort is led by the European Organization for the Safety of Air Navigation (Eurocontrol).

Both NASA and SESAR have published the UTM concept of operations to guide the development of their future air traffic management (ATM) system and make sure safe and efficient integrations of manned and unmanned aircraft into the national airspace.

The UTM composes of UAS operation infrastructure, procedures and local regulation compliance policies to guarantee UAS's safe integration and operation. The main functionality of a UTM includes, but is not limited to, providing means of communication between UAS operators and service providers and a platform to facilitate communication among UAS service providers.

A.2. UAS Service Supplier (USS)

A USS plays an important role to fulfill the key performance indicators (KPIs) that a UTM has to offer. Such Entity acts as a proxy between UAS operators and UTM service providers. It provides services like real-time UAS traffic monitor and planning, aeronautical data archiving, airspace and violation control, interacting with other third-party control entities, etc. A USS can coexist with other USS(s) to build a large service coverage map which can load-balance, relay and share UAS traffic information.

The FAA works with UAS industry shareholders and promotes the Low Altitude Authorization and Notification Capability [LAANC] program

which is the first system to realize some of the UTM envisioned functionality. The LAANC program can automate the UAS's flight plan application and approval process for airspace authorization in real-time by checking against multiple aeronautical databases such as airspace classification and fly rules associated with it, FAA UAS facility map, special use airspace, Notice to Airman (NOTAM), and Temporary Flight Rule (TFR).

A.3. UTM Use Cases for UAS Operations

This section illustrates a couple of use case scenarios where UAS participation in UTM has significant safety improvement.

1. For a UAS participating in UTM and takeoff or land in a controlled airspace (e.g., Class Bravo, Charlie, Delta and Echo in United States), the USS where UAS is currently communicating with is responsible for UAS's registration, authenticating the UAS's fly plan by checking against designated UAS fly map database, obtaining the air traffic control (ATC) authorization and monitor the UAS fly path in order to maintain safe boundary and follow the pre-authorized route.
2. For a UAS participating in UTM and take off or land in an uncontrolled airspace (ex. Class Golf in the United States), pre-fly authorization must be obtained from a USS when operating beyond-visual-of-sight (BVLOS) operation. The USS either accepts or rejects received intended fly plan from the UAS. Accepted UAS operation may share its current fly data such as GPS position and altitude to USS. The USS may keep the UAS operation status near real-time and may keep it as a record for overall airspace air traffic monitor.

A.4. Automatic Dependent Surveillance Broadcast (ADS-B)

The ADS-B is the de facto technology used in manned aviation for sharing location information, which is a ground and satellite based system designed in the early 2000s. Broadcast RID is conceptually similar to ADS-B. However, for numerous technical and regulatory reasons, ADS-B itself is not suitable for low-flying small UA. Technical reasons include: needing RF-LOS to large, expensive (hence scarce) ground stations; needing both a satellite receiver and 1090 MHz transceiver onboard CSWaP constrained UA; the limited bandwidth of both uplink and downlink, which are adequate for the current manned aviation traffic volume, but would likely be saturated by large numbers of UAS, endangering manned aviation; etc. Understanding these technical shortcomings, regulators world-wide have ruled out use of ADS-B for the small UAS for which UAS RID and DRIP are intended.

Authors' Addresses

Stuart W. Card
AX Enterprize
4947 Commercial Drive
Yorkville, NY 13495
USA

Email: stu.card@axenterprize.com

Adam Wiethuechter
AX Enterprize
4947 Commercial Drive
Yorkville, NY 13495
USA

Email: adam.wiethuechter@axenterprize.com

Robert Moskowitz
HTT Consulting
Oak Park, MI 48237
USA

Email: rgm@labs.htt-consult.com

Shuai Zhao
Tencent
2747 Park Blvd
Palo Alto 94588
USA

Email: shuai.zhao@ieee.org

Andrei Gurtov
Linkoeping University
IDA
Linkoeping SE-58183 Linkoeping
Sweden

Email: gurtov@acm.org