

**Question(s):** 14/15

Geneva, 27 January – 7 February 2020

TD**Source:** Editor G.8151/Y.1374**Title:** Draft revised G.8151/Y.1374 (v5.01)**Purpose:** Discussion**Contact:** Yuji Tochio
Fujitsu
JapanTel: +81-44-280-9936
E-mail: tochio@fujitsu.com**Contact:** Hing-Kam Lam
CICT
P.R. ChinaTel: +1 732-275-4646
Email: KamLam@fiberhome.com**Keywords:** G.8151/Y.1374**Abstract:** This document provides the draft revised G.8151/Y.1374.**Document history:**

Version	Date	Description
5.0	11/2018	(Base document for this draft)
5.01	TDxxx/3 (02/2020)	<p>Update:</p> <ul style="list-style-type: none">• Clause 6 to 8 in align with latest G.874 per C1619• Update GFP related description (Table 7-3 and 8-2) per C1870. (Note: Table 7-1 and 7-2 are kept as they are) <p>To DO</p> <ul style="list-style-type: none">• Need to consider a number of FFS (For Futher Study) in this recommendation Per Study Group 15 Guidelines for Recommendation Development Lifecycle• Need to have more investigation to update the GFP requirements of ODUkP/MT_A_Sk and ODUkP-h/MT_A_Sk in Table 7-1 and 7-2 as proposed by C1870

ITU-T

TELECOMMUNICATION
STANDARDIZATION SECTOR
OF ITU

G.8151/Y.1374

(11/2018)

SERIES G: TRANSMISSION SYSTEMS AND MEDIA,
DIGITAL SYSTEMS AND NETWORKS

Packet over Transport aspects – MPLS over Transport
aspects

SERIES Y: GLOBAL INFORMATION
INFRASTRUCTURE, INTERNET PROTOCOL ASPECTS,
NEXT-GENERATION NETWORKS, INTERNET OF
THINGS AND SMART CITIES

Internet protocol aspects – Transport

**Management aspects of the MPLS-TP network
element**

Recommendation ITU-T G.8151/Y.1374

ITU-T G-SERIES RECOMMENDATIONS
TRANSMISSION SYSTEMS AND MEDIA, DIGITAL SYSTEMS AND NETWORKS

INTERNATIONAL TELEPHONE CONNECTIONS AND CIRCUITS	G.100–G.199
GENERAL CHARACTERISTICS COMMON TO ALL ANALOGUE CARRIER-TRANSMISSION SYSTEMS	G.200–G.299
INDIVIDUAL CHARACTERISTICS OF INTERNATIONAL CARRIER TELEPHONE SYSTEMS ON METALLIC LINES	G.300–G.399
GENERAL CHARACTERISTICS OF INTERNATIONAL CARRIER TELEPHONE SYSTEMS ON RADIO-RELAY OR SATELLITE LINKS AND INTERCONNECTION WITH METALLIC LINES	G.400–G.449
COORDINATION OF RADIOTELEPHONY AND LINE TELEPHONY	G.450–G.499
TRANSMISSION MEDIA AND OPTICAL SYSTEMS CHARACTERISTICS	G.600–G.699
DIGITAL TERMINAL EQUIPMENTS	G.700–G.799
DIGITAL NETWORKS	G.800–G.899
DIGITAL SECTIONS AND DIGITAL LINE SYSTEM	G.900–G.999
MULTIMEDIA QUALITY OF SERVICE AND PERFORMANCE – GENERIC AND USER-RELATED ASPECTS	G.1000–G.1999
TRANSMISSION MEDIA CHARACTERISTICS	G.6000–G.6999
DATA OVER TRANSPORT – GENERIC ASPECTS	G.7000–G.7999
PACKET OVER TRANSPORT ASPECTS	G.8000–G.8999
Ethernet over Transport aspects	G.8000–G.8099
MPLS over Transport aspects	G.8100–G.8199
Synchronization, quality and availability targets	G.8200–G.8299
Service Management	G.8600–G.8699
ACCESS NETWORKS	G.9000–G.9999

For further details, please refer to the list of ITU-T Recommendations.

Recommendation ITU-T G.8151/Y.1374

Management aspects of the MPLS-TP network element

Summary

Recommendation ITU-T G.8151/Y.1374 addresses management aspects of the multi-protocol label switching (MPLS) transport profile (MPLS-TP) capable network element containing transport functions of one or more of the layer networks of the MPLS-TP network. The management of the MPLS-TP layer networks is separable from that of its client layer networks so that the same means of management can be used regardless of the client. The management functions for fault management, configuration management, performance monitoring and security management are specified.

This Recommendation aligns with the MPLS-TP architecture and requirements jointly developed by IETF and ITU-T and provides the specification for managing MPLS-TP network elements (NEs) that support the operations, administration, maintenance (OAM) protocol neutral equipment functionality as defined in Recommendations ITU-T G.8121/Y.1381, G.8121.1/Y.1381.1 and G.8121.2/Y.1381.2.

History

Edition	Recommendation	Approval	Study Group	Unique ID*
1.0	ITU-T G.8151/Y.1374	2007-10-22	15	11.1002/1000/9188
2.0	ITU-T G.8151/Y.1374	2012-07-22	15	11.1002/1000/11518
2.1	ITU-T G.8151/Y.1374 (2012) Amd. 1	2012-10-29	15	11.1002/1000/11811
2.2	ITU-T G.8151/Y.1374 (2012) Amd. 2	2013-10-07	15	11.1002/1000/12017
3.0	ITU-T G.8151/Y.1374	2015-01-13	15	11.1002/1000/12386
3.1	ITU-T G.8151/Y.1374 (2015) Amd. 1	2016-04-13	15	11.1002/1000/12825
4.0	ITU-T G.8151/Y.1374	2017-08-13	15	11.1002/1000/13319
5.0	ITU-T G.8151/Y.1374	2018-11-29	15	11.1002/1000/13763

Keywords

Configuration, equipment management, fault, MPLS-TP, performance monitoring, transport resource.

* To access the Recommendation, type the URL <http://handle.itu.int/> in the address field of your web browser, followed by the Recommendation's unique ID. For example, <http://handle.itu.int/11.1002/1000/11830-en>.

FOREWORD

The International Telecommunication Union (ITU) is the United Nations specialized agency in the field of telecommunications, information and communication technologies (ICTs). The ITU Telecommunication Standardization Sector (ITU-T) is a permanent organ of ITU. ITU-T is responsible for studying technical, operating and tariff questions and issuing Recommendations on them with a view to standardizing telecommunications on a worldwide basis.

The World Telecommunication Standardization Assembly (WTSA), which meets every four years, establishes the topics for study by the ITU-T study groups which, in turn, produce Recommendations on these topics.

The approval of ITU-T Recommendations is covered by the procedure laid down in WTSA Resolution 1.

In some areas of information technology which fall within ITU-T's purview, the necessary standards are prepared on a collaborative basis with ISO and IEC.

NOTE

In this Recommendation, the expression "Administration" is used for conciseness to indicate both a telecommunication administration and a recognized operating agency.

Compliance with this Recommendation is voluntary. However, the Recommendation may contain certain mandatory provisions (to ensure, e.g., interoperability or applicability) and compliance with the Recommendation is achieved when all of these mandatory provisions are met. The words "shall" or some other obligatory language such as "must" and the negative equivalents are used to express requirements. The use of such words does not suggest that compliance with the Recommendation is required of any party.

INTELLECTUAL PROPERTY RIGHTS

ITU draws attention to the possibility that the practice or implementation of this Recommendation may involve the use of a claimed Intellectual Property Right. ITU takes no position concerning the evidence, validity or applicability of claimed Intellectual Property Rights, whether asserted by ITU members or others outside of the Recommendation development process.

As of the date of approval of this Recommendation, ITU had not received notice of intellectual property, protected by patents, which may be required to implement this Recommendation. However, implementers are cautioned that this may not represent the latest information and are therefore strongly urged to consult the TSB patent database at <http://www.itu.int/ITU-T/ipr/>.

© ITU 2019

All rights reserved. No part of this publication may be reproduced, by any means whatsoever, without the prior written permission of ITU.

Table of Contents

	Page
1	Scope..... 1
2	References..... 2
3	Definitions 3
3.1	Terms defined elsewhere 3
3.2	Terms defined in this Recommendation 4
4	Abbreviations and acronyms 4
5	Conventions 7
6	MPLS-TP management architecture..... 7
6.1	MPLS-TP network management architecture 7
6.2	MPLS-TP equipment management architecture 10
6.3	Information flows over management points 11
7	Fault (maintenance) management 12
7.1	Fault management applications 12
7.2	Fault management functions..... 14
8	Configuration management 21
8.1	Hardware 21
8.2	Software..... 21
8.3	Protection switching 21
8.4	Trail termination 21
8.5	Adaptation 25
8.6	Diagnostic 37
8.7	Connection..... 43
8.8	Degraded (DEG) thresholds 44
8.9	XXX_Reported..... 44
8.10	Alarm severity 44
8.11	Alarm reporting control 44
8.12	PM thresholds 44
8.13	TCM activation..... 44
8.14	Date and time..... 45
9	Accounting management 45
10	Performance management 45
10.1	Performance management applications 46
10.2	Performance monitoring functions 46
11	Security management..... 49

Bibliography..... 50

Recommendation ITU-T G.8151/Y.1374

Management aspects of the MPLS-TP network element

1 Scope

This Recommendation addresses management aspects of the multi-protocol label switching (MPLS) transport profile (MPLS-TP) capable network element containing transport functions of one or more of the layer networks of the MPLS-TP network. The management of the MPLS-TP layer networks is separable from that of its client layer networks so that the same means of management can be used regardless of the client. In this version of the Recommendation, fault management, configuration management, performance management and security management are specified. Accounting management is for further study.

The generic requirements for managing transport network elements (NEs) are specified in [ITU-T G.7710] and the requirements for the management of equipment used in networks supporting an MPLS-TP are specified in [b-IETF RFC 5951]. This Recommendation specifies the requirements for managing the following MPLS-TP specific equipment functional blocks, which are defined in [ITU-T G.8121]:

- MPLS-TP layer connection function;
- MPLS-TP layer trail termination functions;
- MPLS-TP server to MPLS-TP client adaptation functions;
- MPLS-TP server to Ethernet client adaptation functions;
- synchronous digital hierarchy (SDH) server to MPLS-TP client adaptation functions;
- plesiochronous digital hierarchy (PDH) server to MPLS-TP client adaptation functions;
- optical transport network (OTN) sever to MPLS-TP client adaptation functions;
- Ethernet MAC layer (ETH) sever to MPLS-TP client adaptation functions.

The management of the adaptation of other clients and servers with respect to MPLS-TP is for further study.

This Recommendation also describes the management network organizational model for communication between an element management layer (EML) operations system and the MPLS-TP equipment management function within an MPLS-TP network element.

The architecture described in this Recommendation for the management of MPLS-TP transport networks is based on the following considerations:

- the management view of network element functional elements should be uniform whether those elements form part of an inter-domain interface or part of an intra-domain interface. Those properties necessary to form such a uniform management view are to be included in this Recommendation;
- MPLS-TP layer network entities (MTLNEs) refer to trail termination, adaptation and connection functions as described in [ITU-T G.8110.1];
- a network element may only contain MPLS-TP layer network entities;
- a network element may contain both MTLNEs and client layer network entities (CLNEs);
- client layer entities are managed as part of their own logical domain (e.g., Ethernet management network);
- CLNE and MTLNE may or may not share a common message communication function (MCF) and management application function (MAF) depending on the application;

- CLNE and MTLNE may or may not share the same agent;
- server layer network entities (SLNEs) and MTLNEs may or may not share the same agent.

This Recommendation provides a representation of the MPLS-TP technology using the methodologies that have been used for other transport technologies (e.g., SDH, OTN and Ethernet).

2 References

The following ITU-T Recommendations and other references contain provisions which, through reference in this text, constitute provisions of this Recommendation. At the time of publication, the editions indicated were valid. All Recommendations and other references are subject to revision; users of this Recommendation are therefore encouraged to investigate the possibility of applying the most recent edition of the Recommendations and other references listed below. A list of the currently valid ITU-T Recommendations is regularly published. The reference to a document within this Recommendation does not give it, as a stand-alone document, the status of a Recommendation.

- [ITU-T G.707] Recommendation ITU-T G.707/Y.1322 (2007), *Network node interface for the synchronous digital hierarchy (SDH)*.
- [ITU-T G.709] Recommendation ITU-T G.709/Y.1331 (2016), *Interfaces for the optical transport network*.
- ~~[ITU-T G.805] Recommendation ITU-T G.805 (2000), *Generic functional architecture of transport networks*.~~
- [ITU-T G.806] Recommendation ITU-T G.806 (2012), *Characteristics of transport equipment – Description methodology and generic functionality*.
- [ITU-T G.7041] Recommendation ITU-T G.7041/Y.1303 (2016), *Generic framing procedure (GFP)*.
- [ITU-T G.7044] Recommendation ITU-T G.7044/Y.1347 (2011), *Hitless adjustment of ODUflex (GFP)*.
- [ITU-T G.7710] Recommendation ITU-T G.7710/Y.1701 (2012), *Common equipment management function requirements*.
- [ITU-T G.7712] Recommendation ITU-T G.7712/Y.1703 (2010), *Architecture and specification of data communication network*,
- [ITU-T G.8051] Recommendation ITU-T G.8051/Y.1345 (2017/2020), *Management aspects of the Ethernet Transport (ET) capable network element*.
- [ITU-T G.8110.1] Recommendation ITU-T G.8110.1/Y.1370.1 (2011), *Architecture of MPLS Transport Profile (MPLS-TP) layer network*.
- [ITU-T G.8112] Recommendation ITU-T G.8112/Y.1373 (2020), *Interfaces for the MPLS transport profile layer network*
- [ITU-T G.8113.1] Recommendation ITU-T G.8113.1/Y.1372.1 (2016), *Operations, administration and maintenance mechanism for MPLS-TP in packet transport networks*.
- [ITU-T G.8113.2] Recommendation ITU-T G.8113.2/Y.1372.2 (2016), *Operations, administration and maintenance mechanisms for MPLS-TP networks using the tools defined for MPLS*.
- [ITU-T G.8121] Recommendation ITU-T G.8121/Y.1381 (2018), *Characteristics of MPLS-TP equipment functional blocks*.

- [ITU-T G.8121.1] Recommendation ITU-T G.8121.1/Y.1381.1 (2018), *Characteristics of MPLS Transport Profile (MPLS-TP) equipment functional blocks supporting G.8113.1/Y.1372.1 OAM mechanisms.*
- [ITU-T G.8121.2] Recommendation ITU-T G.8121.2/Y.1381.2 (2018), *Characteristics of MPLS Transport Profile (MPLS-TP) equipment functional blocks supporting G.8113.2/Y.1372.2 OAM mechanisms.*
- ~~[ITU-T M.20] Recommendation ITU-T M.20 (1992), *Maintenance philosophy for telecommunication networks.*~~
- [ITU-T M.3010] Recommendation ITU-T M.3010 (2000), *Principles for a telecommunications management network.*
- [ITU-T M.3013] Recommendation ITU-T M.3013 (2000), *Considerations for a telecommunications management network.*
- [ITU-T M.3100] Recommendation ITU-T M.3100 (2005), *Generic network information model.*
- [ITU-T X.700] Recommendation ITU-T X.700 (1992), *Management framework for Open Systems Interconnection (OSI) For CCITT Applications.*
- [ITU-T X.701] Recommendation ITU-T X.701 (1997), *Information technology – Open Systems Interconnection – Systems management overview.*
- ~~[ITU-T X.733] Recommendation ITU-T X.733 (1992), *Information technology – Open Systems Interconnection – Systems Management: Alarm reporting function.*~~
- ~~[ITU-T X.735] Recommendation ITU-T X.735 (1992), *Information technology – Open Systems Interconnection – Systems management: Log control function.*~~
- [ITU-T Y.1563] Recommendation ITU-T Y.1563 (2009), *Ethernet frame transfer and availability performance.*

3 Definitions

3.1 Terms defined elsewhere

This Recommendation uses the following terms defined elsewhere:

- 3.1.1 agent:** [ITU-T X.701]
- 3.1.2 alarm reporting:** [ITU-T M.3100]
- 3.1.3 alarm reporting control (ARC):** [ITU-T M.3100]
- 3.1.4 atomic function (AF):** [ITU-T G.806]
- 3.1.5 data communication network (DCN):** [ITU-T G.7712]
- 3.1.6 local craft terminal:** [ITU-T G.7710]
- 3.1.7 managed entity:** [ITU-T M.3100]
- 3.1.8 managed object (MO):** [ITU-T X.700]
- 3.1.9 managed object class (MOC):** [ITU-T X.701]
- 3.1.10 management application function (MAF):** [ITU-T G.7710]
- 3.1.11 management interface:** [ITU-T M.3100]
- 3.1.12 management point (MP):** [ITU-T G.806]
- 3.1.13 manager:** [ITU-T X.701]

- 3.1.14 **message communication function (MCF):** [ITU-T M.3013]
- 3.1.15 **network element (NE):** [ITU-T M.3010]
- 3.1.16 **network element function (NEF):** [ITU-T M.3010]
- 3.1.17 **operations system:** [ITU-T M.3010]
- 3.1.18 **operations system function:** [ITU-T M.3100]
- 3.1.19 **persistence interval:** [ITU-T M.3100]
- 3.1.20 **Q-interface:** [ITU-T M.3010]
- 3.1.21 **qualified problem:** [ITU-T M.3100]
- 3.1.22 **timed interval:** [ITU-T M.3100]
- 3.1.23 **workstation function (WF):** [ITU-T M.3010]

3.2 Terms defined in this Recommendation

This Recommendation defines the following terms:

3.2.1 MPLS-TP management network (MT.MN): An MPLS-TP management network is a subset of a telecommunication management network (TMN) that is responsible for managing the parts of a network element that contain MPLS-TP layer network entities. A MT.MN may be subdivided into a set of MPLS-TP management subnetworks.

3.2.2 MPLS-TP management subnetwork (MT.MSN): An MPLS-TP management subnetwork (MT.MSN) consists of a set of separate embedded control channels (ECCs) and associated intra-site data communication links which are interconnected to form a data communication network (DCN) within any given MPLS-TP transport topology. For MPLS-TP, the physical channel supporting the ECC is the MPLS-TP management communication channel (MCC) as defined in [ITU-T G.7712]. A MT.MSN represents a MPLS-TP specific local communication network (LCN) portion of a network operator's overall DCN or telecommunication management network (TMN).

3.2.3 MPLS-TP network element (MT.NE): The part of a network element that contains entities from one or more MPLS-TP layer networks. A MT.NE may therefore be a standalone physical entity or a subset of a network element. It supports at least network element functions (NEFs) and may also support an operations system function (OSF). It contains managed objects (MOs), a message communication function (MCF) and a management application function (MAF). The functions of a MT.NE may be contained within a network element (NE) that also supports other layer networks. These layer network entities are considered to be managed separately from MPLS-TP entities. As such they are not part of the MPLS-TP management network (MT.MN) or MPLS-TP management subnetwork (MT.MSN).

4 Abbreviations and acronyms

This Recommendation uses the following abbreviations and acronyms:

1SL	One-Way Synthetic Loss
AcSL	Accepted Signal Label
AF	Atomic Function
AIS	Alarm Indication Signal
ALM	ALarM reporting
ARC	Alarm Reporting Control
CC	Continuity Check

CLNE	Client Layer Network Entity
CoS	Class of Service
CP	Connection Point
CSF	Client Signal Fail
CTP	Connection Termination Point
CtrlP	Control Plane
DCN	Data Communication Network
DEG	Degraded
DLM	Direct Loss Measurement
DM	Delay Measurement
ECC	Embedded Communication Channel
E-LSP	Explicitly TC-encoded-PSC LSP
EMF	Equipment Management Function
EML	Element Management Layer
EMS	Element Management System
ETH	Ethernet MAC layer
FCAPS	Fault management, Configuration management, Account management, Performance management and Security management
FLR	Frame Loss Ratio
GNE	Gateway Network Element
ILM	Inferred Loss Measurement
IP	Internet Protocol
LAN	Local Area Network
LCK	Locked
LCN	Local Communication Network
LCT	Local Craft Terminal
LM	Loss Measurement
L-LSP	Label-only-inferred PSC LSP
LSP	Label Switched Path
MAC	Media Access Control
MAF	Management Application Function
MCC	Management Communication Channel
MCF	Message Communication Function
MD	Mediation Device
MEP	Maintenance entity group End Point
MF	Mediation Function
MgmtP	Management Plane

MI	Management Information
MIB	Management Information Base
MIP	Maintenance entity group Intermediate Point
MN	Management Network
MO	Managed Object
MOC	Managed Object Class
MP	Management Point
MPLS	Multi-Protocol Label Switching
MPLS-TP	MPLS Transport Profile
MSN	Management SubNetwork
MSRP	MPLS-TP Shared Ring Protection
MT.C	MPLS-TP Channel layer (Note – Equivalent to MPLS-TP transport service layer)
MTLNE	MPLS-TP Layer Network Entity
MTM-n	MPLS-TP Transport Module layer n
MT.MN	MPLS-TP MN
MT.MSN	MPLS-TP MSN
MT.NE	MPLS-TP NE
MT.P	MPLS-TP Path layer
MT.S	MPLS-TP Section layer
NALM	No ALaRm reporting
NALM-CD	No ALaRm reporting, Count Down
NALM-NR	No ALaRm reporting, Not Ready
NALM-QI	No ALaRm reporting, Qualified Inhibit
NALM-TI	No ALaRm reporting, Timed Inhibit
NE	Network Element
NEF	Network Element Function
NEL	Network Element Layer
OAM	Operations, Administration and Maintenance
OAMP	Operations, Administration, Maintenance and Provisioning
OS	Operations System
OSF	Operations System Function
OSI	Open Systems Interconnection
OTN	Optical Transport Network
PDH	Plesiochronous Digital Hierarchy
PHB	Per Hop Behaviour
PMC	Performance Monitoring Clock
PSC	PHB Scheduling Class

PW	Pseudowire
QoS	Quality of Service
RTC	Real Time Clock
RTR	Reset Threshold Report
SCC	Signalling Communication Channel
SDH	Synchronous Digital Hierarchy
SES	Severely Errored Seconds
SLNE	Server Layer Network Entity
TCM	Tandem Connection Monitoring
TLV	Type Length Value
TMN	Telecommunication Management Network
TR	Threshold Report
TTL	Time-To-Live
TTP	Trail Termination Point
WAN	Wide Area Network
WS	WorkStation
WTR	Wait To Restore

5 Conventions

In this Recommendation, MT.MN stands for MPLS-TP management network, MT.MSN for MPLS-TP management subnetwork, MT.NE for MPLS-TP NE, MT.C for MPLS-TP channel layer, MT.P for MPLS-TP path layer and MT.S for MPLS-TP section layer.

6 MPLS-TP management architecture

See clause 6 of [ITU-T G.7710] for the generic architecture for managing transport equipment. MPLS-TP specific management architecture is described below.

The transport layer networks of MPLS-TP are described in [ITU-T G.8110.1], [ITU-T G.8112], [ITU-T G.8121], [ITU-T G.8121.1] and [ITU-T G.8121.2]. The management of the MPLS-TP layer networks is separable from that of its client layer networks so that the same means of management can be used regardless of the client.

[Editor note: If we try to in align with G.874, we should list Arch, Interface and Equipment, but not OAM]

6.1 MPLS-TP ~~network~~ management network architecture

~~The transport layer network architecture of MPLS-TP is described in [ITU-T G.8110.1]. The management of the MPLS-TP layer networks is separable from that of its client layer networks so that the same means of management can be used regardless of the client.~~

6.1.1 Relationship between TMN, MT.MN and MT.MSN

~~The MPLS-TP management network (MT.MN) may be partitioned into MPLS-TP management subnetworks (MT.MSNs).~~ The inter-relationship between a management network, its subnetworks and a telecommunication management network (TMN) as generically described in clause 6.1.1 of [ITU-T G.7710] is applicable to MPLS-TP.

This Recommendation defines the MPLS-TP management network (MT.MN) and subnetworks (MT.MSNs).

6.1.2 Access to the MT.MSN

See clause 6.1.2 of [ITU-T G.7710] for the generic requirements.

6.1.3 MT.MSN requirements

See clause 6.1.3 of [ITU-T G.7710] for the generic requirements.

In addition all MT.NEs must support message communication functions (MCFs). The MCF of an MT.NE initiates/terminates (in the sense of the lower protocol layers), forwards, or otherwise processes management messages over management communication channels (MCCs), or over other DCN interfaces. In addition:

- all MT.NEs are required to terminate the MT.S-MCCs. In OSI terms, this means that each NE must be able to perform the functions of an end system;
- MT.NEs may also be required to forward management messages between ports according to routing control information held in the MT.NE. In OSI terms, this means that some MT.NEs may be required to perform the functions of an intermediate system;
- in addition to supporting interfaces for the MT.S-MCC, a MT.NE may also be required to support other DCN interfaces, which may include MT.P-MCCs, or MT.C-MCCs or an Ethernet DCN interface.

The use of the MT.P-MCCs and MT.C-MCCs for management communications is within the scope of this Recommendation, [see clause 6.1.7](#).

6.1.4 MT.MSN data communication network

Refer to clause 6.1.4 of [ITU-T G.7710] for the generic requirements.

6.1.4.1 Management communication channel

The MT.MN supports three MCCs:

- 1) MT.S-MCC (MCC_S);
- 2) MT.P-MCC (MCC_P);
- 3) MT.C-MCC (MCC_C).

The general MT.S-, MT.P- and MT.C-MCCs are described in [ITU-T G.7712].

Figure 6-1 illustrates a network scenario consisting of two operators. Operator B provides an MT.P Service to Operator A (i.e., Operator B transports the MT.P signal that begins and ends Operator A's domain). According to [ITU-T G.8110.1], the MCC_P and the MCC_C signals passed transparently through Operator B's network.

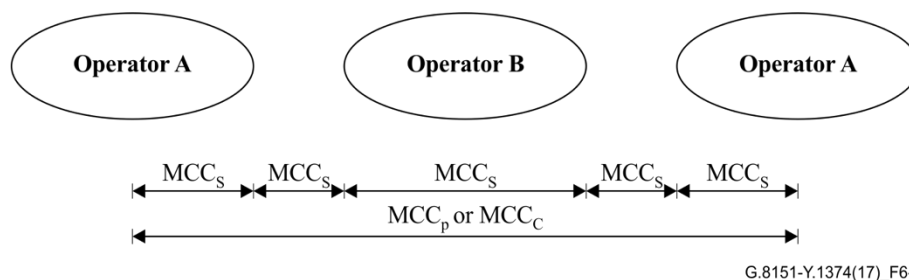

Figure 6-1 – MCC scenarios

The physical layer is terminated in every network element and its related adaptation function provides the MT.S signals as well as the MCC_S. Hence, the MCC_S cannot cross administrative domains. In Figure 6-1, Figure 6-2 and Figure 6-3 illustrate scenarios where the MCC_P and MCC_C are transported transparently through Operator B's domain (the Operator B network elements are not shown in Figure 6-2 and Figure 6-3). In these scenarios, it is possible that Operator B may use the MCC_S within its own domain for the management of its domain.

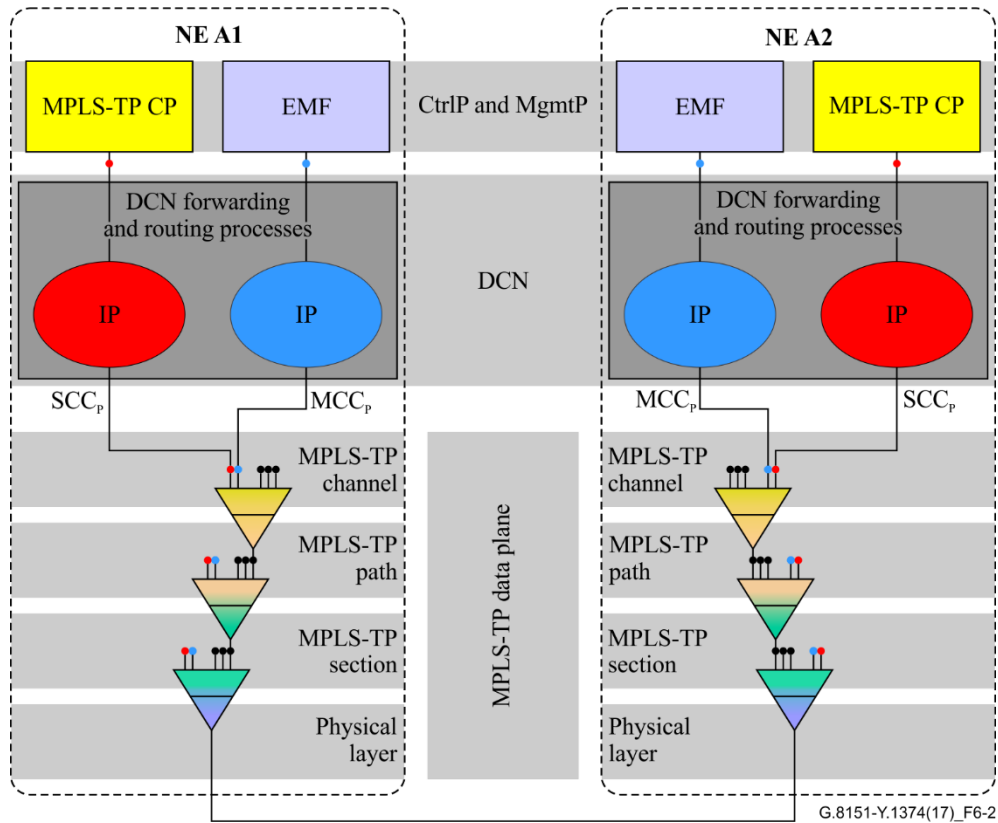

Figure 6-2 – MCC_P scenario example 1

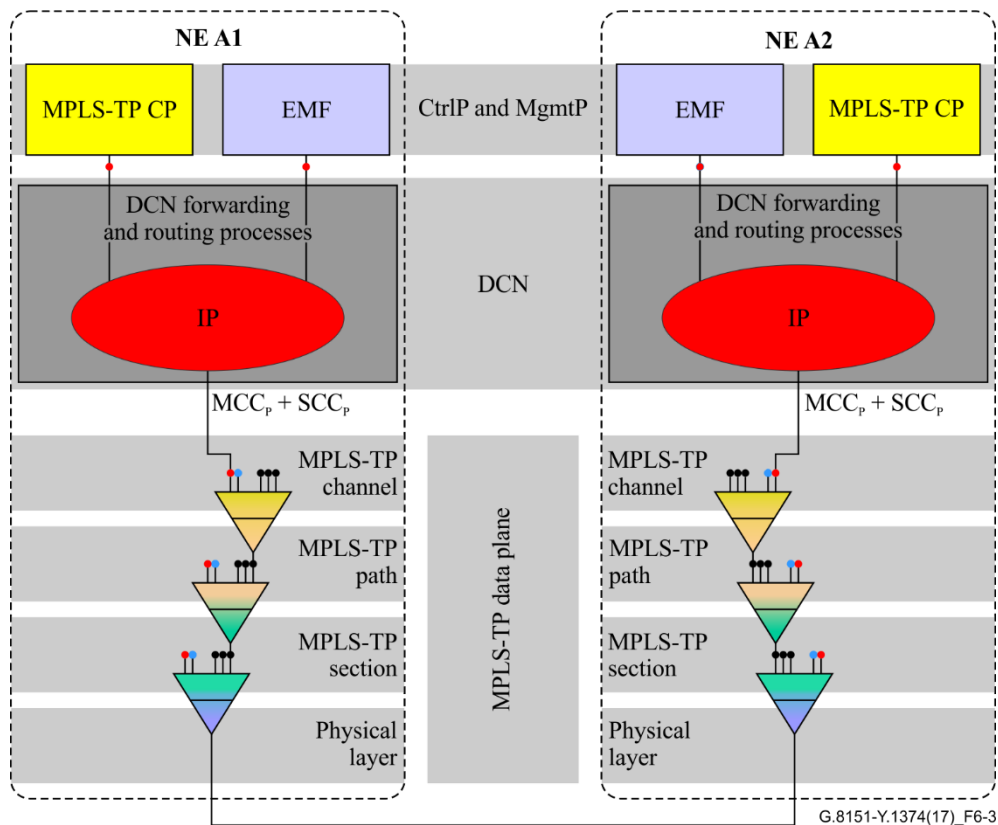

Figure 6-3 – MCC_P scenario example 2

6.1.4.2 MCC physical characteristics

The MT.S-, MT.C- and MT.P-MCCs are logical elements within the MPLS-TP transport module layer n (MTM-n). The MCC provides general management communications between two MPLS-TP network elements with access to the MT.S, MT.P and MT.C characteristic information respectively. The MT.S-, MT.P-, or MT.C-MCC is provided by the MPLS-TP operations, administration and maintenance (OAM) function at section, path, or channel layer as described in [ITU-T G.7712] or by any other embedded communication channel (ECC) of the MPLS-TP transport network.

The MT.S management communication channel (MCC_S) shall operate as a single message channel between MT.S termination points. The bit rate of the MCC_S shall be configurable.

The MT.P management communication channel (MCC_P) shall operate as a single message channel between any network elements that terminate the MT.P layer. The MCC_P is transported transparently through MT.NEs that only terminates the MT.S layer and forwards the MT.P signal. The bit rate of the MCC_P shall be configurable.

The MT.C management communication channel (MCC_C) shall operate as a single message channel between any network elements that terminate the MT.C layer. The MCC_C is transported transparently through MT.NEs that only terminates the MT.S layer or the MT.S and MT.P layers and forwards the MT.C signal. The bit rate of the MCC_C shall be configurable.

6.1.4.3 MCC data link layer protocol

The MCC data link protocols for management applications are under study for [ITU-T G.7712].

6.1.5 Management of DCN

See clause 6.1.5 of [ITU-T G.7710] for the generic requirements.

6.1.6 Remote log-in

See clause 6.1.6 of [ITU-T G.7710] for the generic requirements.

6.1.7 Relationship between technology domains

See clause 6.1.7 of [ITU-T G.7710] for the generic requirements.

6.2 MPLS-TP equipment management architecture

See clause 6.2 of [ITU-T G.7710] for a generic description of the equipment management architecture.

Figure 6-4 below is from Figure 5 of G.7710 that shows the functions inside the MT NE.

~~This clause provides an overview of the minimum functions that are required to support inter-vendor/network communications and single-ended maintenance of MT.NEs within a management subnetwork (MSN), or between communicating peer MT.NEs across a network interface. Single-ended maintenance is the ability to access remotely located MT.NEs to perform maintenance functions (see clause 10.1 of [ITU-T G.7710]).~~

~~The management functions have been categorized according to the classifications given in [ITU-T X.700].~~

~~Detailed specifications of the management functions, in terms of managed objects classes, attributes and message specification are for further study.~~

~~The MPLS-TP equipment management function (EMF) (see Figure 6-4) provides the means through which the MPLS-TP network element function (NEF) is managed by an internal or external manager. If a network element (NE) contains an internal manager, this manager will be part of the MPLS-TP EMF.~~

~~The MPLS-TP EMF interacts with the other atomic functions (AFs) (refer to [ITU-T G.8121]) by exchanging information across the management point (MP) reference points. See [ITU-T G.806] and [ITU-T G.8121] for more information on atomic functions and on MPs. The MPLS-TP EMF contains a number of functions that provide a data reduction mechanism on the information received across the MP reference points. The outputs of these functions are available to the agent via the network element resources and management application functions (MAF) which represent this information as managed objects.~~

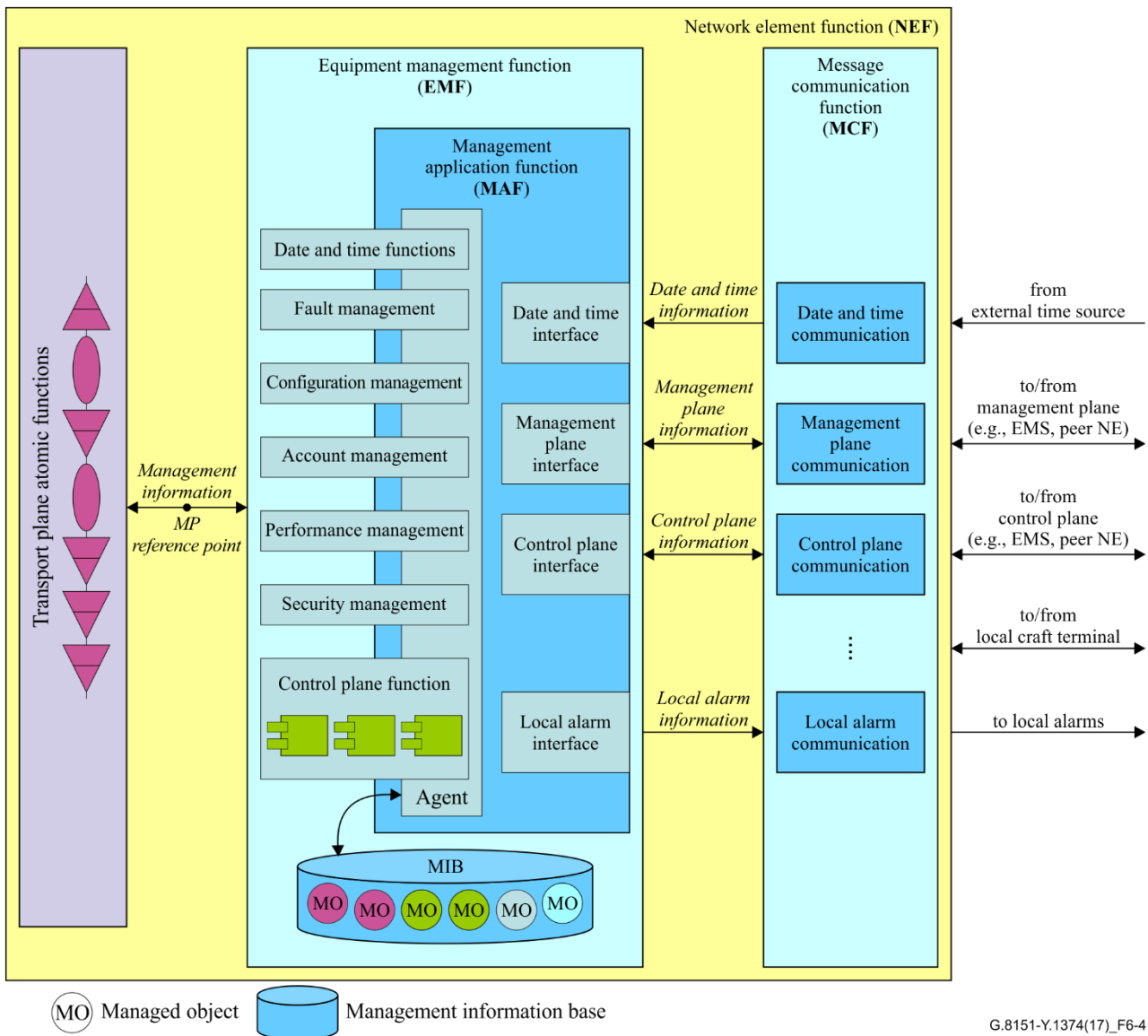

Figure 6.4 – MPLS-TP equipment management function (from Figure 5/G.7710)

Network element resources provide event processing and storage. The MAF processes the information provided to and by the NE resources. The agent converts this information to management messages and responds to management messages from the manager by performing the appropriate operations on the managed objects.

This information to and from the agent is passed to the message communication function (MCF).

6.3 Information flows over management points

See clause 6.3 of [ITU-T G.7710] for the generic description of the information flows over management points (MPs).

The information flow over the MP reference points is described in specific detail for each atomic function in [ITU-T G.8121], [ITU-T G.8121.1] and [ITU-T G.8121.2]. Note that these information flows and associated functions apply equally to both the client and supervisory channel due to the independent nature of these signals. This implies neither that the supervisory channel shall provide all the functions described, nor that [ITU-T G.8121], [ITU-T G.8121.1] and [ITU-T G.8121.2] will provide the details of which functions are available.

The information flows described in this clause are functional. The existence of these information flows in the equipment will depend on the functionality provided by the MPLS-TP NE and the options selected.

The information flow over the MP reference points that arises from anomalies and defects detected in the atomic functions is described in specific details for each atomic function in [ITU-T G.8121].

The information flow over the MP reference points that arises from provisioning and reporting data is described in specific details for each atomic function in [ITU-T G.8121]. The information listed under the Input columns in the tables in clauses 9, 10 and 11 of [ITU-T G.8121], [ITU-T G.8121.1] and [ITU-T G.8121.2] refers to the provisioning data that is passed from the MPLS-TP EMF to the atomic functions. The information listed under the Output column of those tables refers to the reports passed to the MPLS-TP EMF from the atomic functions.

7 Fault (maintenance) management

See clause 7 of [ITU-T G.7710] for the generic requirements for fault management. MT-specific specifications, if needed, are explicitly described.

Fault management is a set of functions which enables the detection, isolation and correction of abnormal operation of the telecommunication network and its environment. It provides facilities for the performance of the maintenance phases from [ITU-T M.20]. The quality assurance measurements for fault management include component measurements for reliability, availability and survivability.

7.1 Fault management applications

See clause 7.1 of [ITU-T G.7710] for a description of the basic fault management applications.

7.1.1 Supervision

See clause 7.1.1 of [ITU-T G.7710] for a generic description of the supervision applications.

The supervision process describes the way in which the actual occurrence of a disturbance or fault is analysed with the purpose of providing an appropriate indication of performance and/or detected fault condition to maintenance personnel. The supervision philosophy is based on the concepts underlying the functional model of [ITU-T G.805], [ITU-T G.8110.1] and the alarm reporting function of [ITU-T X.733].

The five basic supervision categories are related to: transmission, quality of service, processing, equipment and environment. These supervision processes are able to declare fault causes, which need further validation before the appropriate alarm is reported. See [ITU-T G.7710] for additional discussion of these categories.

The MT.NE shall indicate to the OS when a termination point is no longer able to supervise the signal (e.g., implementing equipment has a fault or loss of power).

7.1.1.1 Transmission supervision

See clause 7.1.1.1 of [ITU-T G.7710] for a description of transmission supervision.

For MT.NE, the defects that must be monitored for the purpose of transmission supervision are defined in clause 6.1 of [ITU-T G.8121].

The atomic function associated failure conditions are listed in clause 7.2.1.

7.1.1.2 Quality of service supervision

See clause 7.1.1.2 of [ITU-T G.7710] for a description of quality of service supervision.

7.1.1.3 Processing supervision

See [clause 7.1.1.3 of \[ITU-T G.7710\]](#) for a description of processing supervision.

7.1.1.4 Hardware supervision

See [clause 7.1.1.4 of \[ITU-T G.7710\]](#) for a description of equipment supervision.

7.1.1.5 Environment supervision

See [clause 7.1.1.5 of \[ITU-T G.7710\]](#) for a description of environmental supervision.

7.1.2 Validation

See [clause 7.1.2 of \[ITU-T G.7710\]](#) for a description of fault cause validation.

7.1.3 Alarm handling

7.1.3.1 Severity assignment

See [clause 7.1.3.1 of \[ITU-T G.7710\]](#) for a description of severity categories.

7.1.3.2 Alarm reporting control

[See clause 7.1.3.2 of \[ITU-T G.7710\] for a description of alarm reporting control \(ARC\).](#)

~~Alarm reporting control (ARC) provides an automatic in-service provisioning capability.~~

~~The following ARC states may be specified for a managed entity:~~

~~ALM — Alarm reporting; alarm reporting is turned on.~~

~~NALM — No alarm reporting; alarm reporting is turned off.~~

~~NALM CD — No alarm reporting, count down; this is a substate of NALM-QI and performs the persistence timing countdown function when the managed entity is qualified problem free.~~

~~NALM NR — No alarm reporting, not ready; this is a substate of NALM-QI and performs a wait function until the managed entity is qualified problem free.~~

~~NALM-QI — No alarm reporting, qualified Inhibit; alarm reporting is turned off until the managed entity is qualified problem free for a specified persistence interval.~~

~~NALM-TI — No alarm reporting, timed inhibit; alarm reporting is turned off for a specified timed interval.~~

~~Alarm reporting may be turned off (using NALM, NALM-TI, or NALM-QI) on a per-managed entity basis to allow sufficient time for customer testing and other maintenance activities in an "alarm free" state. Once a managed entity is ready, alarm reporting is automatically turned on (to ALM). The managed entity may be automatically turned on either by using NALM-TI or NALM-QI and allowing the resource to transition out automatically, or by invoking first the NALM state from an element management system (EMS) and when maintenance activity is done, invoking the ALM state. This later automation is carried out by the EMS. For further details relating to ARC, see [ITU-T M.3100].~~

7.1.3.3 Reportable failures

See [clause 7.1.3.3 of \[ITU-T G.7710\]](#) for a description of reportable failures.

7.1.3.4 Alarm reporting

[See clause 7.1.3.4 of \[ITU-T G.7710\] for a description of alarm surveillance.](#)

~~Alarm surveillance is concerned with the detection and reporting of relevant events and conditions which occur in the network. In a network, events and conditions detected within the equipment and incoming signals should be reportable. In addition, a number of events external to the equipment~~

should also be reportable. Alarms are indications that are automatically generated by an NE as a result of the declaration of a failure. The OS shall have the ability to define which events and conditions generate autonomous reports and which shall be reported on request.

The following alarm-related functions shall be supported:

- 1) — autonomous reporting of alarms;
- 2) — request for reporting of all alarms;
- 3) — reporting of all alarms;
- 4) — allow or inhibit of autonomous alarm reporting;
- 5) — reporting on request status of allow or inhibit alarm reporting;
- 6) — reporting of protection switch events.

7.1.3.4.1 Local reporting

See [clause 7.1.3.4.1 of \[ITU-T G.7710\]](#) for a description of local reporting.

7.1.3.4.2 TMN reporting

See [clause 7.1.3.4.2 of \[ITU-T G.7710\]](#) for a description of TMN reporting.

7.2 Fault management functions

Figure 7-1 ~~below is from Figure 7-1 of G.7710 that show~~^{contains} the functional model of fault management inside the MPLS-TP EMF. ~~This model is consistent with the alarm flow functional model, specified in [ITU-T M.3100]. It does not address configuration aspects relating to fault management, the full ARC functional model, nor does it define where all possible event report parameters get assigned. Figure 7-1 is intended only to illustrate which well-known functions are impacted by the ARC, and which are not, and to provide a generalized alarm flow view.~~

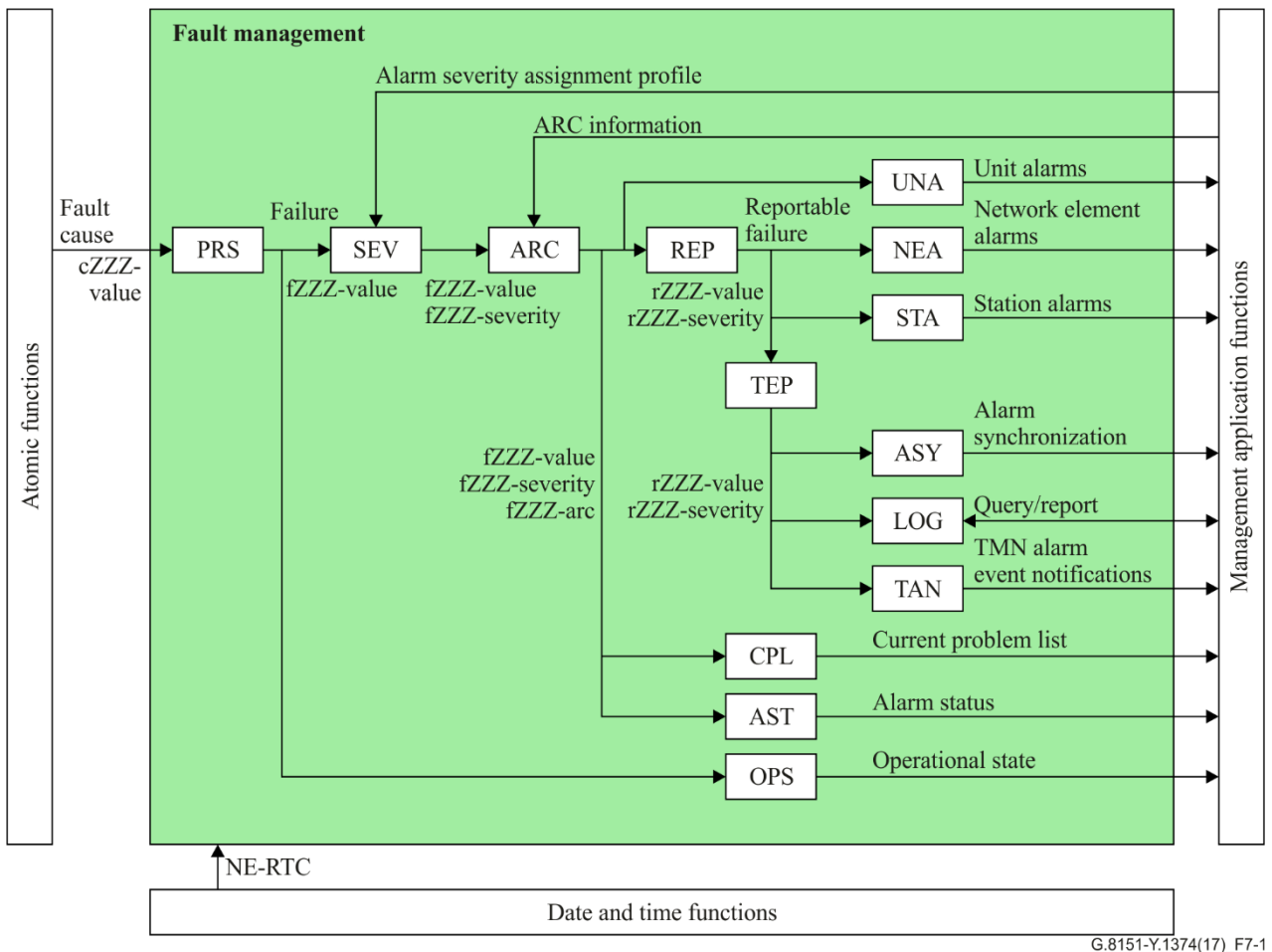

Figure 7-1 – Fault management within the MPLS-TP NEF (from Figure 7-1/G.7710)

7.2.1 Fault cause persistency function – PRS

See clause 7.2.1 of [ITU-T G.7710] for a description of PRS.

The defect correlations provide a data reduction mechanism on the fault and performance monitoring primitives' information presented at the MP reference points.

The equipment management function within the network element performs a persistency check on the fault causes (that are reported across the MP reference points) before it declares a fault cause a failure. In addition to the transmission failures, hardware failures with signal transfer interruption are also reported at the input of the fault cause function for further processing. See Figure 7-2.

Symbol

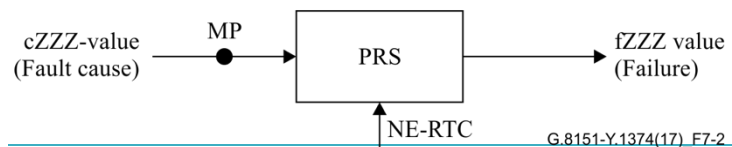

Figure 7-2 – Fault cause persistency function

For MT.NE that supports the following functions specified in [ITU-T G.8121], the EMF PRS process shall support the persistency check for the fault causes listed in Table 7-1.

Inputs and outputs

Table 7-1 – Inputs/outputs for the fault cause persistency function

Atomic function (ITU-T G.8121)	Input	Output
MT_C	cFOP-PMb cFOP-PMc cFOP-CM cFOP-NR cFOP-TO	fFOP-PMb fFOP-PMc fFOP-CM fFOP-NR fFOP-TO
MTp_C	cFOP-PMb cFOP-PMc cFOP-CM cFOP-NR cFOP-TO	fFOP-PMb fFOP-PMc fFOP-CM fFOP-NR fFOP-TO
MT_TT_Sk	cSSF cLCK cLOC cMMG cUNM cUNP cUNC cDEG cRDI	fSSF fLCK fLOC fMMG fUNM fUNP fUNC fDEG fRDI
MT/ETH_A_Sk	cCSF	fCSF
Sn/MT_A_Sk	cPLM cLFD cEXM cUPM	fPLM fLFD fEXM fUPM
Sn-X-L/MT_A_Sk	cPLM cLFD cEXM cUPM	fPLM fLFD fEXM fUPM
Sm/MT_A_Sk	cPLM cLFD cEXM cUPM	fPLM fLFD fEXM fUPM
Sm-X-L/MT_A_Sk	cPLM cLFD cEXM cUPM	fPLM fLFD fEXM fUPM
Pq/MT_A_Sk	cPLM cLFD cEXM cUPM	fPLM fLFD fEXM fUPM
Pq-X-L/MT_A_Sk	cPLM cLFD cEXM cUPM	fPLM fLFD fEXM fUPM

Table 7-1 – Inputs/outputs for the fault cause persistency function

Atomic function ([ITU-T G.8121])	Input	Output
ODUKP/MT_A_Sk	cPLM cLFD cEXM cUPM	fPLM fLFD fEXM fUPM
ODUKP-h/MT_A_Sk	cPLM cLFD cEXM cUPM	fPLM fLFD fEXM fUPM

See [ITU-T G.7710] for the mapping of failure (fXXX) to the generic probable cause to be used in alarm reporting.

Process

~~The equipment management function within the network element performs a persistency check on the fault causes before it declares a fault cause a failure.~~

~~A transmission failure (fXXX) shall be declared if the fault cause persists continuously for 2.5 ± 0.5 s. The failure shall be cleared if the fault cause is absent continuously for 10 ± 0.5 s.~~

~~The specific set of failures associated with each atomic function is listed in Table 7-1.~~

~~The failure declaration and clearing shall be time stamped. The time stamp shall indicate the time at which the fault cause is activated at the input of the fault cause persistency (i.e., defect-to-failure integration) function and the time at which the fault cause is deactivated at the input of the fault cause persistency function.~~

7.2.2 Severity assignment function – SEV

See [clause 7.2.2 of \[ITU-T G.7710\]](#) for a description of the severity assignment function.

7.2.3 Alarm reporting control function – ARC

[See clause 7.2.3 of \[ITU-T G.7710\] for a description of the severity reporting control function \(ARC\).](#)

~~The ARC function allows a management system to control the alarm reporting on a managed entity basis as defined in [ITU-T M.3100].~~

The alarms that can be controlled with this function are defined for each atomic function in [ITU-T G.8121].

~~The following ARC states may be specified for a managed entity:~~

~~ALM — Alarm reporting; alarm reporting is turned on.~~

~~NALM — No alarm reporting; alarm reporting is turned off.~~

~~NALM-CD — No alarm reporting, count down; this is a substate of NALM-QI and performs the persistence timing countdown function when the managed entity is qualified problem free.~~

~~NALM-NR — No alarm reporting, not ready; this is a substate of NALM-QI and performs a wait function until the managed entity is qualified problem free.~~

~~NALM-QI — No alarm reporting, qualified inhibit; alarm reporting is turned off until the managed entity is qualified problem free for a specified persistence interval.~~

~~NALM-TI — No alarm reporting, timed inhibit; alarm reporting is turned off for a specified timed interval.~~

~~The ALM state is required for all managed entities that can detect alarms.~~

~~In addition, at least one of the states: NALM, NALM-TI, or NALM-QI must be supported.~~

~~If NALM-QI is supported, then NALM-NR is required and NALM-CD is optional.~~

For MT.NE that supports the following atomic functions specified in [ITU-T G.8121], the EMF ARC process shall support the ARC function for the failures listed in Table 7-2.

Table 7-2 – ARC specifications for MPLS-TP

Atomic function	Qualified problems	QoS reporting	Default state value
MT_C	fFOP-PMb fFOP-PMc fFOP-CM fFOP-NR fFOP-TO	For further study	ALM
MTp_C	fFOP-PMb fFOP-PMc fFOP-CM fFOP-NR fFOP-TO	For further study	ALM
MT_TT_Sk	fSSF fLCK fLOC fMMG fUNM fUNP fUNC fDEG fRDI	For further study	ALM
MT/ETH_A_Sk	fCSF	For further study	ALM
Sn/MT_A_Sk	fPLM fLFD fEXM fUPM	For further study	ALM
Sn-X-L/MT_A_Sk	fPLM fLFD fEXM fUPM	For further study	ALM
Sm/MT_A_Sk	fPLM fLFD fEXM fUPM	For further study	ALM

Table 7-2 – ARC specifications for MPLS-TP

Atomic function	Qualified problems	QoS reporting	Default state value
Sm-X-L/MT_A_Sk	fPLM fLFD fEXM fUPM	For further study	ALM
Pq/MT_A_Sk	fPLM fLFD fEXM fUPM	For further study	ALM
Pq-X-L/MT_A_Sk	fPLM fLFD fEXM fUPM	For further study	ALM
ODUkP/MT_A_Sk	fPLM fLFD fEXM fUPM	For further study	ALM
ODUkP-h/MT_A_Sk	fPLM fLFD fEXM fUPM	For further study	ALM

7.2.4 Reportable failure function – REP

See [clause 7.2.4 of \[ITU-T G.7710\]](#) for a description of the reportable failure function.

7.2.5 Unit alarms function – UNA

See [clause 7.2.5 of \[ITU-T G.7710\]](#) for a description of the unit alarms function.

7.2.6 Network element alarms function – NEA

See [clause 7.2.6 of \[ITU-T G.7710\]](#) for a description of the network element alarms function.

7.2.7 Station alarms function – STA

See [clause 7.2.7 of \[ITU-T G.7710\]](#) for a description of the station alarms function.

7.2.8 TMN event pre-processing function – TEP

See [clause 7.2.8 of \[ITU-T G.7710\]](#) for a description of the TMN event pre-processing function.

7.2.9 Alarm synchronization function – ASY

See [clause 7.2.9 of \[ITU-T G.7710\]](#) for a description of the alarm synchronization function.

7.2.10 Logging function – LOG

~~Alarm history management is concerned with the recording of alarms. Historical data shall be stored in registers in the NE. Each register contains all the parameters of an alarm message.~~

~~Registers shall be readable on demand or periodically. The OS can define the operating mode of the registers as wrapping or stop when full. The OS may also flush the registers or stop recording at any time.~~

~~NOTE—Wrapping is the deletion of the earliest record to allow a new record when a register is full. Flushing is the removal of all records in the register. See [ITU-T X.735] for additional details.~~

See [clause 7.2.10](#) of [ITU-T G.7710] for a description of the logging function.

7.2.11 TMN alarm event notification function – TAN

See [clause 7.2.11](#) of [ITU-T G.7710] for a description of the TMN alarm event notification function.

7.2.12 Current problem list function – CPL

See [clause 7.2.12](#) of [ITU-T G.7710] for a description of the current problem list function.

7.2.13 Alarm status function – AST

See [clause 7.2.13](#) of [ITU-T G.7710] for a description of the alarm status function.

7.2.14 Operational state function – OPS

See [clause 7.2.14](#) of [ITU-T G.7710] for a description of the operational state function.

For MT.NE that supports the following functions specified in [ITU-T G.8121], the EMF OPS process shall support the failures listed in Table 7-3, which lists the failures that could influence the operational state of the related objects.

Table 7-3 – Operational state function input and output signals for MPLS-TP

Atomic function	Failure input (fZZZ-value)	Operational state output (enabled/disabled)
MT_C	fFOP-PMb fFOP-PMc fFOP-CM fFOP-NR fFOP-TO	Enabled Enabled Enabled Enabled Enabled
MTp_C	fFOP-PMb fFOP-PMc fFOP-CM fFOP-NR fFOP-TO	Enabled Enabled Enabled Enabled Enabled
MT_TT_Sk	fSSF fLCK fLOC fMMG fUNM fUNP fUNC fDEG fRDI	Enabled Enabled Enabled Enabled Enabled Enabled Enabled Enabled Enabled
Sn/MT_A_Sk	fPLM fLFD fEXM	Enabled Enabled Enabled

Table 7-3 – Operational state function input and output signals for MPLS-TP

Atomic function	Failure input (fZZZ-value)	Operational state output (enabled/disabled)
	fUPM	Enabled
Sn-X-L/MT_A_Sk	fPLM fLFD fEXM fUPM	Enabled Enabled Enabled Enabled
Sm/MT_A_Sk	fPLM fLFD fEXM fUPM	Enabled Enabled Enabled Enabled
Sm-X-L/MT_A_Sk	fPLM fLFD fEXM fUPM	Enabled Enabled Enabled Enabled
Pq/MT_A_Sk	fPLM fLFD fEXM fUPM	Enabled Enabled Enabled Enabled
Pq-X-L/MT_A_Sk	fPLM fLFD fEXM fUPM	Enabled Enabled Enabled Enabled
ODUKP/MT_A_Sk	fPLM fLFD fEXM fUPM	Disabled Enabled Disabled Enabled Disabled Enabled Disabled Enabled
ODUKP-h/MT_A_Sk	fPLM fLFD fEXM fUPM	Disabled Enabled Disabled Enabled Disabled Enabled Disabled Enabled

7.2.15 External events

For further study.

8 Configuration management

See [clause 8 of](#) [ITU-T G.7710] for the generic requirements for configuration management. MPLS-TP detailed specifications, if needed, are explicitly described.

8.1 Hardware

See [clause 8.1 of](#) [ITU-T G.7710] for a description of hardware management.

8.2 Software

See [clause 8.2 of](#) [ITU-T G.7710] for a description of software management.

8.3 Protection switching

See [clause 8.3 of \[ITU-T G.7710\]](#) for a description of the generic management requirements for protection switching. ~~The MPLS-TP specific management requirements will be provided after the protection switching process is defined in [ITU-T G.8121].~~

This function allows a user to provision and monitor the operation of protection processes deployed in an MT connection process defined in clause 9.1 of [ITU-T G.8121].

MI signals concerning the protection processes are listed in Table 8-4 and communicated between the EMF and the protection process through the management point. According these MI signals, the EMF generates a corresponding event notification and state report signals to the MAF.

For the protection processes supported by an MT.NE, the MT.NE EMF shall support the following management functions:

- Provisioning the protection switching management information
- Retrieving the protection switching management information
- Notifying the changes of the protection switching management information
- Receiving the monitored protection switching management information

8.4 Trail termination

See [clause 8.4 of \[ITU-T G.7710\]](#) for a description of trail termination management.

This function allows a user to provision and monitor the operation of the MPLS-TP Trail Termination process.

The management information (MI) signals listed in the table(s) of this clause are communicated between the EMF and the MPLS-TP trail termination process across the MP within the MT.NE.

For MT.NE that supports the MT_TT function specified in [ITU-T G.8121], the EMF shall support the following management functions for the MI listed in Table 8-1:

- provisioning the trail termination management information;
- retrieving the trail termination management information;
- notifying the changes of the trail termination management information;
- receiving the monitored trail termination management information.

Table 8-1 – Provisioning and reporting for termination functions

MI signal	Value range	Default value
MT_TT_So Provisioning		
MT_TT_SO_MI_GAL_ENABLE	True, false	(Note 3)
MT_TT_So_MI_TTLVALUE	0 to 255	255
MT_TT_So_MI_MEG_ID	String; values are OAM protocol-specific	(Note 1)
MT_TT_So_MI_MEP_ID	String; values are OAM protocol-specific	(Note 1)
MT_TT_So_MI_CC_OAM_Tool	[ITU-T G.8113.1], [ITU-T G.8113.2]	N/A
MT_TT_So_MI_RDI_OAM_Tool	[ITU-T G.8113.1], [ITU-T G.8113.2]	N/A
MT_TT_So_MI_CC_Enable	True, false	False

Table 8-1 – Provisioning and reporting for termination functions

MI signal	Value range	Default value
MT_TT_So_MI_CVp_Enable	True, false The combination of MT_TT_So_MI_CC_Enable= false and MT_TT_So_MI_CVp_Enable =true is not allowed.	False
MT_TT_So_MI_CC_CoS	0, 1, 2, 3, 4, 5, 6, 7	7
MT_TT_So_MI_CC_Period	3.33 ms, 10 ms, 100 ms, 1 s, 10 s, 1 min, 10 min	100 ms
MT_TT_So_MI_1LMp_Enable	True, false	False
MT_TT_So_MI_LMp_OAM_Tool[1... M _{LMp}]	[ITU-T G.8113.1], [ITU-T G.8113.2]	N/A
MT_TT_So_MI_LMp_Enable[1... M _{LMp}]	True, false	False
MT_TT_So_MI_LMp_Period[1... M _{LMp}]	100 ms, 1 s, 10 s	100 ms
MT_TT_So_MI_LMp_CoS[1... M _{LMp}]	0, 1, 2, 3, 4, 5, 6, 7	–
MT_TT_So_MI_DMp_OAM_Tool[1... M _{DMp}]	[ITU-T G.8113.1], [ITU-T G.8113.2]	N/A
MT_TT_So_MI_DMp_Enable[1... M _{DMp}]	True, false	False
MT_TT_So_MI_DMp_Period[1... M _{DMp}]	100 ms, 1 s, 10 s	100 ms
MT_TT_So_MI_DMp_Test_ID[1... M _{DMp}]	(Note 2)	–
MT_TT_So_MI_DMp_CoS[1... M _{DMp}]	0, 1, 2, 3, 4, 5, 6, 7	–
MT_TT_So_MI_DMp_Length[1... M _{DMp}]	Non-negative integer representing number of bytes for the length of the padding type length value (TLV).	0
MT_TT_So_MI_1DMp_OAM_Tool[1... M _{1DMp}]	[ITU-T G.8113.1], [ITU-T G.8113.2]	N/A
MT_TT_So_MI_1DMp_Enable[1... M _{1DMp}]	True, false	False
MT_TT_So_MI_1DMp_Period[1... M _{1DMp}]	100 ms, 1 s, 10 s	100 ms
MT_TT_So_MI_1DMp_Test_ID[1... M _{1DMp}]	(Note 2)	–
MT_TT_So_MI_1DMp_CoS[1... M _{1DMp}]	0, 1, 2, 3, 4, 5, 6, 7	–
MT_TT_So_MI_1DMp_Length[1... M _{1DMp}]	Non-negative integer representing number of bytes for the length of the padding TLV.	0
MT_TT_So_MI_SLp_OAM_Tool[1... M _{SLp}]	[ITU-T G.8113.1], [ITU-T G.8113.2]	N/A
MT_TT_So_MI_SLp_Enable[1... M _{SLp}]	True, false	False
MT_TT_So_MI_SLp_Period[1... M _{SLp}]	100 ms, 1 s, 10 s	100 ms
MT_TT_So_MI_SLp_Test_ID[1... M _{SLp}]	(Note 2)	–
MT_TT_So_MI_SLp_CoS[1... M _{SLp}]	0, 1, 2, 3, 4, 5, 6, 7	–
MT_TT_So_MI_SLp_Length[1... M _{SLp}]	Non-negative integer representing number of bytes	0

Table 8-1 – Provisioning and reporting for termination functions

MI signal	Value range	Default value
	for the length of the padding TLV.	
MT_TT_So_MI_1SLp_OAM_Tool[1...M _{1SLp}]	[ITU-T G.8113.1], [ITU-T G.8113.2]	N/A
MT_TT_So_MI_1SLp_Enable[1...M _{1SLp}]	True, false	False
MT_TT_So_MI_1SLp_Period[1...M _{1SLp}]	100 ms, 1 s, 10 s	100 ms
MT_TT_So_MI_1SLp_CoS[1...M _{1SLp}]	0, 1, 2, 3, 4, 5, 6, 7	–
MT_TT_So_MI_1SLp_Test_ID[1...M _{1SLp}]	(Note 2)	–
MT_TT_So_MI_1SLp_Length[1...M _{1SLp}]	Non-negative integer representing number of bytes for the length of the padding TLV.	0
MT_TT_Sk Provisioning		
MT_TT_Sk_MI_GAL_Enable	True, false	(Note 3)
MT_TT_Sk_MI_MEG_ID	String; values are OAM protocol-specific	(Note 2)
MT_TT_Sk_MI_PeerMEP_ID	String; values are OAM protocol-specific	Empty list
MT_TT_Sk_MI_CC_OAM_Tool	[ITU-T G.8113.1], [ITU-T G.8113.2]	N/A
MT_TT_Sk_MI_RDI_OAM_Tool	[ITU-T G.8113.1], [ITU-T G.8113.2]	N/A
MT_TT_Sk_MI_CC_Enable	True, false	False
MT_TT_Sk_MI_CVp_Enable	True, false The combination of MT_TT_Sk_MI_CC_Enable=false and MT_TT_Sk_MI_CVp_Enable=true is not allowed.	False
MT_TT_Sk_MI_CC_Period	3.33 ms, 10 ms, 100 ms, 1 s, 10 s, 1 min, 10 min	100 ms
MT_TT_Sk_MI_CC_CoS	0, 1, 2, 3, 4, 5, 6, 7	7
MT_TT_Sk_MI_1LMp_Enable	True, false	False
MT_TT_Sk_MI_Get_SvdCC	Last received continuity check (CC) frame(s) that caused defect	–
MT_TT_Sk_MI_LMp_OAM_Tool[1... M _{LMp}]	[ITU-T G.8113.1], [ITU-T G.8113.2]	N/A

Table 8-1 – Provisioning and reporting for termination functions

MI signal	Value range	Default value
MT_TT_Sk_MI_LMp_Enable[1... M _{LMp}]	True, false	False
MT_TT_Sk_MI_LMp_CoS[1... M _{LMp}]	0, 1, 2, 3, 4, 5, 6, 7	–
MT_TT_Sk_MI_LM_DEGM	2-10; See Table 7-1 of [ITU-T G.806]	10
MT_TT_Sk_MI_LM_M	2-10	10
MT_TT_Sk_MI_LM_DEGTHR	0% to 100%; See Table 7-1 of [ITU-T G.806]	30%
MT_TT_Sk_MI_LM_TFMIN	For further study	For further study
MT_TT_Sk_MI_1second	–	–
MT_TT_Sk_MI_DMp_OAM_Tool[1... M _{DMp}]	[ITU-T G.8113.1], [ITU-T G.8113.2]	N/A
MT_TT_Sk_MI_DMp_Enable[1... M _{DMp}]	True, false	False
MT_TT_Sk_MI_DMp_CoS[1... M _{DMp}]	0, 1, 2, 3, 4, 5, 6, 7	–
MT_TT_Sk_MI_1DMp_OAM_Tool[1... M _{1DMp}]	[ITU-T G.8113.1], [ITU-T G.8113.2]	N/A
MT_TT_Sk_MI_1DMp_Enable[1...M _{1DMp}]	True, false	False
MT_TT_Sk_MI_1DMp_Test_ID[1...M _{1DMp}]	(Note 2)	–
MT_TT_Sk_MI_SLp_OAM_Tool[1... M _{SLp}]	[ITU-T G.8113.1], [ITU-T G.8113.2]	N/A
MT_TT_Sk_MI_SLp_Enable[1... M _{SLp}]	True, false	False
MT_TT_Sk_MI_SLp_CoS[1... M _{SLp}]	0, 1, 2, 3, 4, 5, 6, 7	–
MT_TT_Sk_MI_1SLp_OAM_Tool	[ITU-T G.8113.1], [ITU-T G.8113.2]	N/A
MT_TT_Sk_MI_1SLp_Enable[1... M _{1SLp}]	True, false	False
MT_TT_Sk_MI_1SLp_Test_ID[1... M _{1SLp}]	(Note 2)	–
MT_TT_Sk_MI_AIS_OAM_Tool	[ITU-T G.8113.1], [ITU-T G.8113.2]	N/A
MT_TT_Sk_MI_LCK_OAM_Tool	[ITU-T G.8113.1], [ITU-T G.8113.2]	N/A
MT_TT_Sk Reporting		
MT_TT_Sk_MI_SvdCC	Last received CC packet(s) that causes the defect	–
<p>NOTE 1 – A value must be provided at provisioning.</p> <p>NOTE 2 – The Test ID field is optional when this proactive measurement tool is used.</p> <p>NOTE 3 – MI_GAL_Enable must be set to true on label switched paths (LSPs) and sections, and to false on pseudowires (PWs). Setting it to true for PWs is for further study.</p>		

8.4.1 Trail termination – ITU-T G.8121.1 specific

For MT.NE that supports the MT_TT function specified in [ITU-T G.8121.1], there is no additional MI to be managed beyond those listed in Table 8-1.

NOTE – In [ITU-T G.8121.1], MI_LMC_Enable and MI_LML_Enable are used to mean MI_1LMp_Enable and MI_LMp_Enable as described in [ITU-T G.8121].

8.4.2 Trail termination – ITU-T G.8121.2 specific

For MT.NE that supports the MT_TT function specified in [ITU-T G.8121.2], the EMF shall in addition support the management of the MIs listed in Table 8-1.1:

Table 8-1.1 – Provisioning and reporting for termination functions

MI signal	Value range	Default value
MT_TT_So Provisioning		
MT_TT_So_MI_CCCV_Mode[]	Coord, Src, Sink	Coord
MT_TT_So_MI_Local_Discr[]	32-bit value	0
MT_TT_So Reporting		
MT_TT_So_MI_DMp_PeriodChanged[1...MDMp]	True, false	False
MT_TT_So_MI_LMp_PeriodChanged[1...MLMp]	True, false	False
MT_TT_Sk Provisioning		
MT_TT_Sk_MI_CCCV_Mode[]	Coord, Src, Sink	Coord
MT_TT_Sk_MI_Remote_Discr[]	32-bit value	0
MT_TT_Sk_MI_PeerMEPID[]		
MT_TT_Sk_MI_DMp_CopyPad[1...MDMp]	0,128	0
MT_TT_Sk_MI_LMp_LMType[1...MLMp]	Inferred loss measurement (ILM), direct loss measurement (DLM)	
MT_TT_Sk_MI_LMp_CountBytes[1...MLMp]	True, false	True
MT_TT_Sk_MI_PM_ClearError	–	–
MT_TT_Sk_MI_PM_Responder_Enable	True, false	True
MT_TT_Sk Reporting		
MT_TT_Sk_MI_DMp_ReportError(Error)[1...MDMp]	True, false	False
MT_TT_Sk_MI_LMp_ReportError(Error)[1...MLMp]	True, false	False

8.5 Adaptation

See clause 8.5 of [ITU-T G.7710] for a description of adaptation management.

An access point that has multiple adaptation functions connected to it, thereby allowing different clients to be transported via the server signal, requires a mechanism for the selection of the active client.

This function allows a user to provision and monitor the operation of the MPLS-TP adaptation processes.

The MI signals listed in the following table are communicated between the EMF and the adaptation processes across the management point within the MPLS-TP NE.

For MT.NE that supports the adaptation functions specified in [ITU-T G.8121], the EMF shall support the following management functions for the MI listed in Table 8-2:

- provisioning the flow forwarding management information;
- retrieving the flow forwarding management information;

- notifying the changes of the flow forwarding management information.

Table 8-2 – Provisioning and reporting for adaptation functions

MI signal	Value range	Default value
MT/MT_A_So Provisioning		
MT/MT_A_So_MI_Admin_State	Locked (LCK), Normal	Normal
MT/MT_A_So_MI_Label [1...M]	16 to (2**20)-1	(Note 2)
MT/MT_A_So_MI_LSPType[1...M]	Explicitly TC-encoded-PSC LSP (E-LSP), label-only-inferred PSC LSP (L-LSP)	(Note 1)
MT/MT_A_So_MI_CoS[1...M]	(Note 1)	(Note 1)
MT/MT_A_So_MI_PHB2EXPMapping[1...M]	(Note 1)	(Note 1)
MT/MT_A_So_MI_QoSEncodingMode[1...M]	A, B (Note 5)	(Note 2)
MT/MT_A_So_MI_Mode	Mode 1, Mode 2	Mode 1
MT/MT_A_So_MI_LCK_OAM_Tool[1...M]	[ITU-T G.8113.1], [ITU-T G.8113.2]	N/A
MT/MT_A_So_MI_LCK_Period[1...M]	1 s, 1 min	1 s
MT/MT_A_So_MI_LCK_CoS[1...M]	0 to 7	7
MT/MT_A_So_MI_APS_OAM_Tool[1...M]	For further study	For further study
MT/MT_A_So_MI_APS_CoS[1...M]	0 to 7	7
MT/MT_A_So_MI_GAL_Enable[1...M]	True, false	(Note 4)
MT/MT_A_Sk Provisioning		
MT/MT_A_Sk_MI_Admin_State	LCK, Normal	Normal
MT/MT_A_Sk_MI_Label [1...M]	16 to (2**20)-1	(Note 2)
MT/MT_A_Sk_MI_LSPType[1...M]	E-LSP, L-LSP	(Note 1)
MT/MT_A_Sk_MI_CoS[1...M]	(Note 1)	(Note 1)
MT/MT_A_Sk_MI_TC2PHBMapping[1...M]	(Note 1)	(Note 1)
MT/MT_A_Sk_MI_QoSDecodingMode[1...M]	A, B (Note 5)	(Note 2)
MT/MT_A_Sk_MI_Mode	Mode 1, Mode 2	Mode 1
MT/MT_A_Sk_MI_AIS_OAM_Tool[1...M]	[ITU-T G.8113.1], [ITU-T G.8113.2]	N/A
MT/MT_A_Sk_MI_AIS_Period[1...M]	1 s, 1 min	1 s
MT/MT_A_Sk_MI_AIS_CoS[1...M]	0 to 7	7
MT/MT_A_Sk_MI_LCK_OAM_Tool[1...M]	[ITU-T G.8113.1], [ITU-T G.8113.2]	N/A
MT/MT_A_Sk_MI_LCK_Period[1...M]	1 s, 1 min	1 s
MT/MT_A_Sk_MI_LCK_CoS[1...M]	0 to 7	7
MT/MT_A_Sk_MI_APS_OAM_Tool[1...M]	For further study	For further study

Table 8-2 – Provisioning and reporting for adaptation functions

MI signal	Value range	Default value
MT/MT_A_Sk_MI_GAL_Enable [1...M]	True, false	(Note 4)
MT/MSRP_A_So Provisioning		
MT/MSRP_A_So_MI_GAL_Enable	True, false	True
MT/MSRP_A_So_MI_APS_CoS	0...7	
MT/MSRP_A_So_MI_APS_OAM_Tool	MSRP (See [ITU-T G.8121])	N/A
MT/MSRP_A_Sk Provisioning		
MT/MSRP_A_Sk_MI_GAL_Enable	True, false	True
MT/MSRP_A_Sk_MI_APS_OAM_Tool	MSRP (See [ITU-T G.8121])	N/A
MSRP/MT_A_Sk Provisioning		
MSRP/MT_MI_DestNode_ID[1...m]	For further study	For further study
MTDi/MT_A_Sk Provisioning		
MTDi/MT_A_Sk_MI_DS_MP_Type NOTE – This MI should be properly configured by the EMF on the basis of the MPLS-TP connection configuration within the node but not exposed to the operator as a configuration parameter in the NE/EMS management interface. See clause 9.4.2.2.2 of [ITU-T G.8121] and its Appendix I for examples of configuration of this MI.	Maintenance entity group end point (MEP), Maintenance entity group intermediate Point (MIP)	–
MT/ETH_A_So Provisioning		
MT/ETH_A_So_MI_Admin_State	LCK, Normal	Normal
MT/ETH_A_So_MI_FCSEnable	True, false	True
MT/ETH_A_So_MI_CWEnable	True, false	True
MT/ETH_A_So_MI_SQUse	True, false	False
MT/ETH_A_So_MI_PRI2CoSMapping	(Note 1)	(Note 1)
MT/ETH_A_So_MI_MEP_MAC* (Note 3)	6-byte unicast MAC address	–
MT/ETH_A_So_MI_Client_MEL* (Note 3)	0 to 7	7
MT/ETH_A_So_MI_LCK_Period* (Note 3)	1 s, 1 min	1 s
MT/ETH_A_So_MI_LCK_Pri* (Note 3)	0 to 7	7
MT/ETH_A_So_MI_MEL* (Note 3)	0 to 7	7
MT/ETH_A_Sk_MI_GAL_Enable	True, false	(Note 4)
MT/ETH_A_Sk_MI_CSF_OAM_Tool	[ITU-T G.8113.1], [ITU-T G.8113.2]	N/A
MT/ETH_A_So_MI_CSF_Period	(Note 1)	(Note 1)

Table 8-2 – Provisioning and reporting for adaptation functions

MI signal	Value range	Default value
MT/ETH_A_So_MI_CSF_CoS	0 to 7	7
MT/ETH_A_So_MI_CSF_Enable	True, false	False
MT/ETH_A_So_MI_CSFrdifdiEnable	True, false	False
MT/ETH_A_Sk Provisioning		
MT/ETH_A_Sk_MI_FCSEnable	True, false	True
MT/ETH_A_Sk_MI_CWEnable	True, false	False
MT/ETH_A_Sk_MI_SQUse	True, false	False
MT/ETH_A_Sk_MI_GAL_Enable	True, false	(Note 4)
MT/ETH_A_Sk_MI_CoS2PRIMapping	(Note 1)	(Note 1)
MT/ETH_A_Sk_MI_MEL* (Note 3)	0 to 7	7
MT/ETH_A_Sk_MI_Admin_State	LCK, Normal	Normal
MT/ETH_A_Sk_MI_LCK_Period* (Note 3)	1 s, 1 min	1 s
MT/ETH_A_Sk_MI_LCK_Pri* (Note 3)	0 to 7	7
MT/ETH_A_Sk_MI_Client_MEL* (Note 3)	0 to 7	7
MT/ETH_A_Sk_MI_MEP_MAC* (Note 3)	6-byte unicast MAC address	–
MT/ETH_A_Sk_MI_AIS_Pri* (Note 3)	0 to 7	7
MT/ETH_A_Sk_MI_AIS_Period* (Note 3)	1 s, 1 min	1 s
MT/ETH_A_Sk_MI_GAL_Enable	True, false	(Note 4)
MT/ETH_A_Sk_MI_CSF_OAM_Tool	[ITU-T G.8113.1], [ITU-T G.8113.2]	N/A
MT/ETH_A_Sk_MI_CSF_Reported	True, false	False
MT/ETH_A_Sk_MI_CSFrdifdiEnable	True, false	False
MT/SCC_A_So Provisioning		
MT/SCC_A_So_MI_Active	True, false	True
MT/SCC_A_So_MI_ECC_CoS	0 to 7	7
MT/SCC_A_So_MI_GAL_Enable	True, false	(Note 4)
MT/SCC_A_Sk Provisioning		
MT/SCC_A_Sk_MI_Active	True, false	True
MT/SCC_A_Sk_GAL_Enable	True, false	(Note 4)
MT/MCC_A_So Provisioning		
MT/MCC_A_So_MI_Active	True, false	True
MT/MCC_A_So_MI_ECC_CoS	0 to 7	7
MT/MCC_A_So_MI_GAL_enable	True, false	(Note 4)
MT/MCC_A_Sk Provisioning		
MT/MCC_A_Sk_MI_Active	True, false	True
MT/MCC_A_Sk_MI_GAL_Enable	True, false	(Note 4)
Sn/MT_A_So Provisioning		
Sn/MT_A_So_MI_SCCType	0 to 255	32

Table 8-2 – Provisioning and reporting for adaptation functions

MI signal	Value range	Default value
Sn/MT_A_So_MI_Label[1...M]	16 to (2**20)-1	(Note 2)
Sn/MT_A_So_MI_LSPTType[1...M]	E-LSP, L-LSP	–
Sn/MT_A_So_MI_CoS[1...M]	0 to 7	–
Sn/MT_A_So_PHB2TCMapping[1...M]	(Note 1)	–
Sn/MT_A_So_MI_QoSEncodingMode[1...M]	A, B (Note 5)	–
Sn/MT_A_So_MI_Mode[1...M]	Mode 1, Mode 2	Mode 1
Sn/MT_A_Sk Provisioning		
Sn/MT_A_Sk_MI_SCCType	0 to 255	32
Sn/MT_A_Sk_MI_Label[1...M]	16 to (2**20)-1	(Note 2)
Sn/MT_A_Sk_MI_LSPTType[1...M]	E-LSP, L-LSP	(Note 1)
Sn/MT_A_Sk_MI_CoS[1...M]	(Note 1)	(Note 1)
Sn/MT_A_Sk_MI_TC2PHBMapping[1...M]	(Note 1)	(Note 1)
Sn/MT_A_Sk_MI_QoSDecodingMode[1...M]	A, B (Note 5)	(Note 1)
Sn/MT_A_Sk_MI_Mode[1...M]	Mode 1, Mode 2	Mode 1
Sn/MT_A_Sk_MI_LCK_Period[1...M]	1 s, 1 min	1 s
Sn/MT_A_Sk_MI_LCK_CoS[1...M]	0 to 7	–
Sn/MT_A_Sk_MI_LCK_OAM_Tool [1...M]	[ITU-T G.8113.1], [ITU-T G.8113.2]	N/A
Sn/MT_A_Sk_MI_Admin_State	LCK, Normal	Normal
Sn/MT_A_Sk_MI_AIS_Period[1...M]	1 s, 1 min	1 s
Sn/MT_A_Sk_MI_AIS_CoS[1...M]	0 to 7	–
Sn/MT_A_Sk_MI_AIS_OAM_Tool[1...M]	[ITU-T G.8113.1], [ITU-T G.8113.2]	N/A
Sn/MT_A_Sk_MI_GAL_enable[1...M]	True, false	(Note 4)
Sn/MT_A_Sk Reporting		
Sn/MT_A_Sk_MI_AcSL (see Table 9-11 of [ITU-T G.707])	0 to 255	–
Sn/MT_A_Sk_MI_AcEXI (see Table 6-2 of [ITU-T G.7041])	0 to 15	–
Sn/MT_A_Sk_MI_LastValidUPI (see Table 6-3 of [ITU-T G.7041])	0 to 255	–
Sn-X-L/MT_A_So Provisioning		
Sn-X-L/MT_A_So_MI_SCCType (See Table 6-3 of [ITU-T G.7041])	0 to 255	32
Sn-X-L/MT_A_So_MI_Label[1...M]	16 to (2**20)-1	(Note 2)
Sn-X-L/MT_A_So_MI_LSPTType[1...M]	E-LSP, L-LSP	–
Sn-X-L/MT_A_So_MI_CoS[1...M]	0 to 7	(Note 1)
Sn-X-L/MT_A_So_PHB2TCMapping[1...M]	(Note 1)	(Note 1)
Sn-X-L/MT_A_So_MI_QoSEncodingMode[1...M]	A, B (Note 5)	(Note 1)
Sn-X-L/MT_A_So_MI_Mode[1...M]	Mode 1, Mode 2	Mode 1

Table 8-2 – Provisioning and reporting for adaptation functions

MI signal	Value range	Default value
Sn-X-L/MT_A_Sk Provisioning		
Sn-X-L/MT_A_Sk_MI_SCCType (See Table 6-3 of [ITU-T G.7041])	0 to 255	32
Sn-X-L/MT_A_Sk_MI_Label[1...M]	16 to (2**20)-1	(Note 2)
Sn-X-L/MT_A_Sk_MI_LSPTType[1...M]	E-LSP, L-LSP	–
Sn-X-L/MT_A_Sk_MI_CoS[1...M]	0 to 7	(Note 1)
Sn-X-L/MT_A_Sk_MI_TC2PHBMapping[1...M]	(Note 1)	(Note 1)
Sn-X-L/MT_A_Sk_MI_QoSDecodingMode[1...M]	A, B (Note 5)	(Note 1)
Sn-X-L/MT_A_Sk_MI_Mode[1...M]	Mode 1, Mode 2	Mode 1
Sn-X-L/MT_A_Sk_MI_LCK_Period[1...M]	1 s, 1 min	1 s
Sn-X-L/MT_A_Sk_MI_LCK_CoS[1...M]	0 to 7	–
Sn-X-L/MT_A_Sk_MI_LCK_OAM_Tool [1...M]	[ITU-T G.8113.1], [ITU-T G.8113.2]	N/A
Sn-X-L/MT_A_Sk_MI_Admin_State	LCK, Normal	Normal
Sn-X-L/MT_A_Sk_MI_AIS_Period[1...M]	1 s, 1 min	1 s
Sn-X-L/MT_A_Sk_MI_AIS_CoS[1...M]	0 to 7	–
Sn-X-L/MT_A_Sk_MI_AIS_OAM_Tool [1...M]	[ITU-T G.8113.1], [ITU-T G.8113.2]	N/A
Sn-X-L /MT_A_Sk_MI_GAL_Enable [1...M]	True, false	(Note 4)
Sn-X-L/MT_A_Sk Reporting		
Sn-X-L/MT_A_Sk_MI_AcSL (see Table 9-11 of [ITU-T G.707])	0 to 255	–
Sn-X-L/MT_A_Sk_MI_AcEXI (see Table 6-2 of [ITU-T G.7041])	0 to 15	–
Sn-X-L/MT_A_Sk_MI_LastValidUPI (See Table 6-3 of [ITU-T G.7041])	0 to 255	–
Sm/MT_A_So Provisioning		
Sm/MT_A_So_MI_SCCType	0 to 255	32
Sm/MT_A_So_MI_Label[1...M]	16 to (2**20)-1	(Note 2)
Sm/MT_A_So_MI_LSPTType[1...M]	E-LSP, L-LSP	–
Sm/MT_A_So_MI_CoS[1...M]	0 to 7	–
Sm/MT_A_So_PHB2TCMapping[1...M]	(Note 1)	(Note 1)
Sm/MT_A_So_MI_QoSEncodingMode[1...M]	A, B (Note 5)	(Note 1)
Sm/MT_A_So_MI_Mode[1...M]	Mode 1, Mode 2	Mode 1
Sm/MT_A_Sk Provisioning		
Sm/MT_A_Sk_MI_SCCType	0 to 255	32
Sm/MT_A_Sk_MI_Label[1...M]	16 to (2**20)-1	(Note 2)
Sm/MT_A_Sk_MI_LSPTType[1...M]	E-LSP, L-LSP	–
Sm/MT_A_Sk_MI_CoS[1...M]	0 to 7	–

Table 8-2 – Provisioning and reporting for adaptation functions

MI signal	Value range	Default value
Sm/MT_A_Sk_MI_TC2PHBMapping[1...M]	(Note 1)	(Note 1)
Sm/MT_A_Sk_MI_QoSDecodingMode[1...M]	A, B (Note 5)	(Note 1)
Sm/MT_A_Sk_MI_Mode[1...M]	Mode 1, Mode 2	Mode 1
Sm/MT_A_Sk_MI_LCK_Period[1...M]	1 s, 1 min	1 s
Sm/MT_A_Sk_MI_LCK_CoS[1...M]	0 to 7	–
Sm/MT_A_Sk_MI_LCK_OAM_Tool [1...M]	[ITU-T G.8113.1], [ITU-T G.8113.2]	N/A
Sm/MT_A_Sk_MI_Admin_State	LCK, Normal	Normal
Sm/MT_A_Sk_MI_AIS_Period[1...M]	1 s, 1 min	1 s
Sm/MT_A_Sk_MI_AIS_CoS[1...M]	0 to 7	–
Sm/MT_A_Sk_MI_AIS_OAM_Tool[1...M]	[ITU-T G.8113.1], [ITU-T G.8113.2]	N/A
Sm/MT_A_Sk_MI_GAL_Enable[1...M]	True, false	(Note 4)
Sm/MT_A_Sk Reporting		
Sm/MT_A_Sk_MI_AcSL (See Table 9-12 and Table 9-13 of [ITU-T G.707])	0 to 255	–
Sm/MT_A_Sk_MI_AcEXI (See Table 6-2 of [ITU-T G.7041])	0 to 15	–
Sm/MT_A_Sk_MI_LastValidUPI (See Table 6-3 of [ITU-T G.7041])	0 to 255	–
Sm-X-L/MT_A_So Provisioning		
Sm-X-L/MT_A_So_MI_SCCType	0 to 255	32
Sm-X-L/MT_A_So_MI_Label[1...M]	16 to (2**20)-1	(Note 2)
Sm-X-L/MT_A_So_MI_LSPTType[1...M]	E-LSP, L-LSP	–
Sm-X-L/MT_A_So_MI_CoS[1...M]	0 to 7	–
Sm-X-L/MT_A_So_PHB2TCMapping[1...M]	(Note 1)	(Note 1)
Sm-X-L/MT_A_So_MI_QoSEncodingMode[1...M]	A, B (Note 5)	(Note 1)
Sm-X-L/MT_A_So_MI_Mode[1...M]	Mode 1, Mode 2	Mode 1
Sm-X-L/MT_A_Sk Provisioning		
Sm-X-L/MT_A_Sk_MI_SCCType	0 to 255	32
Sm-X-L/MT_A_Sk_MI_Label[1...M]	16 to (2**20)-1	(Note 2)
Sm-X-L/MT_A_Sk_MI_LSPTType[1...M]	E-LSP, L-LSP	–
Sm-X-L/MT_A_Sk_MI_CoS[1...M]	0 to 7	–
Sm-X-L/MT_A_Sk_MI_TC2PHBMapping[1...M]	(Note 1)	(Note 1)
Sm-X-L/MT_A_Sk_MI_QoSDecodingMode[1...M]	A, B (Note 5)	(Note 1)
Sm-X-L/MT_A_Sk_MI_Mode[1...M]	Mode 1, Mode 2	Mode 1
Sm-X-L/MT_A_Sk_MI_LCK_Period[1...M]	1 s, 1 min	1 s
Sm-X-L/MT_A_Sk_MI_LCK_CoS[1...M]	0 to 7	–

Table 8-2 – Provisioning and reporting for adaptation functions

MI signal	Value range	Default value
Sm-X-L/MT_A_Sk_MI_LCK_OAM_Tool [1...M]	[ITU-T G.8113.1], [ITU-T G.8113.2]	N/A
Sm-X-L/MT_A_Sk_MI_Admin_State	LCK, Normal	Normal
Sm-X-L/MT_A_Sk_MI_AIS_Period[1...M]	1 s, 1 min	1 s
Sn-X-L/MT_A_Sk_MI_AIS_CoS[1...M]	0 to 7	–
Sm-X-L/MT_A_Sk_MI_AIS_OAM_Tool [1...M]	[ITU-T G.8113.1], [ITU-T G.8113.2]	N/A
Sm-X-L/MT_A_Sk_MI_GAL_Enable[1...M]	True, false	(Note 4)
Sm-X-L/MT_A_Sk Reporting		
Sm-X-L/MT_A_Sk_MI_AcSL	0 to 255	–
Sm-X-L/MT_A_Sk_MI_AcEXI	0 to 15	–
Sm-X-L/MT_A_Sk_MI_LastValidUPI	0 to 255	–
Pq/MT_A_So Provisioning		
Pq/MT_A_So_MI_SCCType	0 to 255	32
Pq/MT_A_So_MI_Label[1...M]	16 to (2**20)-1	(Note 2)
Pq/MT_A_So_MI_LSPTType[1...M]	E-LSP, L-LSP	–
Pq/MT_A_So_MI_CoS[1...M]	0 to 7	–
Pq/MT_A_So_PHB2TCMapping[1...M]	(Note 1)	(Note 1)
Pq/MT_A_So_MI_QoSEncodingMode[1...M]	A, B (Note 5)	(Note 1)
Pq/MT_A_So_MI_Mode[1...M]	Mode 1, Mode 2	Mode 1
Pq/MT_A_Sk Provisioning		
Pq/MT_A_Sk_MI_SCCType	0 to 255	32
Pq/MT_A_Sk_MI_Label[1...M]	16 to (2**20)-1	(Note 2)
Pq/MT_A_Sk_MI_LSPTType[1...M]	E-LSP, L-LSP	–
Pq/MT_A_Sk_MI_CoS[1...M]	0 to 7	–
Pq/MT_A_Sk_MI_TC2PHBMapping[1...M]	(Note 1)	(Note 1)
Pq/MT_A_Sk_MI_QoSDecodingMode[1...M]	A, B (Note 5)	(Note 1)
Pq/MT_A_Sk_MI_Mode[1...M]	Mode 1, Mode 2	Mode 1
Pq/MT_A_Sk_MI_LCK_Period[1...M]	1 s, 1 min	1 s
Pq/MT_A_Sk_MI_LCK_CoS[1...M]	0 to 7	–
Pq/MT_A_Sk_MI_LCK_Tool[1...M]	[ITU-T G.8113.1], [ITU-T G.8113.2]	N/A
Pq/MT_A_Sk_MI_Admin_State	LCK, Normal	Normal
Pq/MT_A_Sk_MI_AIS_Period[1...M]	1 s, 1 min	1 s
Pq/MT_A_Sk_MI_AIS_CoS[1...M]	0 to 7	–
Pq/MT_A_Sk_MI_AIS_Tool[1...M]	[ITU-T G.8113.1], [ITU-T G.8113.2]	N/A

Table 8-2 – Provisioning and reporting for adaptation functions

MI signal	Value range	Default value
Pq/MT_A_Sk_MI_GAL_Enable [1...M]	True, false	(Note 4)
Pq/MT_A_Sk Reporting		
Pq/MT_A_Sk_MI_AcSL (See clause 2.1.2 of [ITU-T G.832])	0 to 7	–
Pq/MT_A_Sk_MI_AcEXI (See Table 6-2 of [ITU-T G.7041])	0 to 15	–
Pq/MT_A_Sk_MI_LastValidUPI (See Table 6-3 of [ITU-T G.7041])	0 to 255	–
Pq-X-L/MT_A_So Provisioning		
Pq-X-L/MT_A_So_MI_SCCType	0 to 255	32
Pq-X-L/MT_A_So_MI_Label[1...M]	16 to (2**20)-1	(Note 2)
Pq-X-L/MT_A_So_MI_LSPTType[1...M]	E-LSP, L-LSP	–
Pq-X-L/MT_A_So_MI_CoS[1...M]	0 to 7	–
Pq-X-L/MT_A_So_PHB2TCMapping[1...M]	(Note 1)	(Note 1)
Pq-X-L/MT_A_So_MI_QoSEncodingMode[1...M]	A, B (Note 5)	(Note 1)
Pq-X-L /MT_A_So_MI_Mode[1...M]	Mode 1, Mode 2	Mode 1
Pq-X-L/MT_A_Sk Provisioning		
Pq-X-L/MT_A_Sk_MI_SCCType	0 to 255	32
Pq-X-L/MT_A_Sk_MI_Label[1...M]	16 to (2**20)-1	(Note 2)
Pq-X-L/MT_A_Sk_MI_LSPTType[1...M]	E-LSP, L-LSP	–
Pq-X-L/MT_A_Sk_MI_CoS[1...M]	0 to 7	–
Pq-X-L/MT_A_Sk_MI_TC2PHBMapping[1...M]	(Note 1)	(Note 1)
Pq-X-L/MT_A_Sk_MI_QoSDecodingMode[1...M]	A, B (Note 5)	(Note 1)
Pq-X-L/MT_A_Sk_MI_Mode[1...M]	Mode 1, Mode 2	Mode 1
Pq-X-L/MT_A_Sk_MI_LCK_Period[1...M]	1 s, 1 min	1 s
Pq-X-L/MT_A_Sk_MI_LCK_CoS[1...M]	0 to 7	–
Pq-X-L/MT_A_Sk_MI_LCK_Tool[1...M]	[ITU-T G.8113.1], [ITU-T G.8113.2]	N/A
Pq-X-L/MT_A_Sk_MI_Admin_State	LCK, Normal	Normal
Pq-X-L/MT_A_Sk_MI_AIS_Period[1...M]	1 s, 1 min	1 s
Pq-X-LMT_A_Sk_MI_AIS_CoS[1...M]	0 to 7	–
Pq-X-L/MT_A_Sk_MI_AIS_Tool[1...M]	[ITU-T G.8113.1], [ITU-T G.8113.2]	N/A
Pq-X-L//MT_A_Sk_MI_GAL_Enable[1...M]	True, false	(Note 4)
Pq-X-L/MT_A_Sk Reporting		
Pq-X-L/MT_A_Sk_MI_AcSL	0 to 7	–
Pq-X-L/MT_A_Sk_MI_AcEXI	0 to 15	–
Pq-X-L/MT_A_Sk_MI_LastValidUPI	0 to 255	–
ODUKP/MT_A_So Provisioning		

Table 8-2 – Provisioning and reporting for adaptation functions

MI signal	Value range	Default value
ODUKP/MT_A_So_MI_Active	True, false	False
ODUKP/MT_A_So_MI_SCCType	0 to 255	32
ODUKP/MT_A_So_MI_Label[1...M]	16 to (2**20)-1	(Note 2)
ODUKP/MT_A_So_MI_LSPTType[1...M]	E-LSP, L-LSP	–
ODUKP/MT_A_So_MI_CoS[1...M]	0 to 7	–
ODUKP/MT_A_So_PHB2TCMapping[1...M]	(Note 1)	(Note 1)
ODUKP/MT_A_So_MI_QoSEncodingMode[1...M]	A, B (Note 5)	(Note 1)
ODUKP/MT_A_So_MI_Mode[1...M]	Mode 1, Mode 2	Mode 1
ODUKP/MT_A_Sk Provisioning		
ODUKP/MT_A_Sk_MI_Active	True, false	False
ODUKP/MT_A_Sk_MI_SCCType	0 to 255	32
ODUKP/MT_A_Sk_MI_Label[1...M]	16 to (2**20)-1	(Note 2)
ODUKP/MT_A_Sk_MI_LSPTType[1...M]	E-LSP, L-LSP	–
ODUKP/MT_A_Sk_MI_CoS[1...M]	0 to 7	–
ODUKP/MT_A_Sk_MI_TC2PHBMapping[1...M]	(Note 1)	(Note 1)
ODUKP/MT_A_Sk_MI_QoSDecodingMode[1...M]	A, B (Note 5)	(Note 1)
ODUKP/MT_A_So_MI_Mode[1...M]	Mode 1, Mode 2	Mode 1
ODUKP/MT_A_Sk_MI_LCK_Period[1...M]	1 s, 1 min	1 s
ODUKP/MT_A_Sk_MI_LCK_CoS[1...M]	0 to 7	–
ODUKP/MT_A_Sk_MI_LCK_Tool[1...M]	[ITU-T G.8113.1], [ITU-T G.8113.2]	N/A
ODUKP/MT_A_Sk_MI_Admin_State	LCK, Normal	Normal
ODUKP/MT_A_Sk_MI_AIS_Period[1...M]	1 s, 1 min	1 s
ODUKP/MT_A_Sk_MI_AIS_CoS[1...M]	0 to 7	–
ODUKP/MT_A_Sk_MI_AIS_Tool[1...M]	[ITU-T G.8113.1], [ITU-T G.8113.2]	N/A
ODUKP/MT_A_Sk_MI_GAL_Enable[1...M]	True, false	(Note 4)
ODUKP/MT_A_Sk Reporting		
ODUKP/MT_A_Sk_MI_AcPT (See Table 15-8 of [ITU-T G.709])	0 to 255	Not Applicable–
ODUKP/MT_A_Sk_MI_AcEXI (See Table 6-2 of [ITU-T G.7041])	0 to 15	Not Applicable–
ODUKP-h/MT_A_Sk_MI_LastInvalidUPI ODUKP/MT_A_Sk_MI_LastValidUPI (See Table 6-3 of [ITU-T G.7041])	0 to 255	Not Applicable–
ODUKP-h/MT_A_So provisioning		
ODUKP-h/MT_A_So_MI_Active	True, false	False
ODUKP-h/MT_A_So_MI_SCCType	0 to 255	32
ODUKP-h/MT_A_So_MI_Label[1...M]	16 to (2**20)-1	(Note 2)
ODUKP-h/MT_A_So_MI_LSPTType[1...M]	E-LSP, L-LSP	–

Table 8-2 – Provisioning and reporting for adaptation functions

MI signal	Value range	Default value
ODUKP-h/MT_A_So_MI_CoS[1...M]	0 to 7	–
ODUKP-h/MT_A_So_PHB2TCMapping[1...M]	(Note 1)	–
ODUKP-h/MT_A_So_MI_QoSEncodingMode[1...M]	A, B (Note 5)	–
ODUKP-h/MT_A_So_MI_Mode[1...M]	Mode 1, Mode 2	Mode 1
ODUKP-h/MT_A_So_MI_GAL_Enable[1...M]	True, False	(Note 4)
ODUKP-h/MT_A_So_MI_INCREASE	True, false	False
ODUKP-h/MT_A_So_MI_DECREASE	True, false	False
ODUKP-h/MT_A_So_MI_TSNUM	According to [ITU-T G.7044]	N/A
ODUKP-h/MT_A_So_MI_ODUflexRate	<i>FlexCBR, FlexGFP</i>	<i>N/A</i>
ODUKP-h/MT_A_So reporting		
ODUKP-h/MT_A_So_MI_ADJSTATE	According to [ITU-T G.7044]	N/A
ODUKP-h/MT_A_Sk provisioning		
ODUKP-h/MT_A_Sk_MI_Active	True, false	False
ODUKP-h /MT_A_Sk_MI_SCCType	True, false	False
ODUKP-h /MT_A_Sk_MI_Label[1...M]	0 to 255	32
ODUKP-h /MT_A_Sk_MI_LSPTType[1...M]	16 to (2**20)-1	(Note 2)
ODUKP-h /MT_A_Sk_MI_CoS[1...M]	E-LSP, L-LSP	–
ODUKP-h /MT_A_Sk_MI_TC2PHBMapping[1...M]	0 to 7	–
ODUKP-h /MT_A_Sk_MI_QoSDecodingMode[1...M]	(Note 1)	–
ODUKP/MT_A_Sk_MI_Mode[1...M]	A, B (Note 5)	–
ODUKP-h /MT_A_Sk_MI_LCK_Period[1...M]	1 s, 1 min	1 s
ODUKP-h /MT_A_Sk_MI_LCK_CoS[1...M]	0 to 7	7
ODUKP-h /MT_A_Sk_MI_LCK_Tool[1...M]	[ITU-T G.8113.1], [ITU-T G.8113.2]	N/A
ODUKP-h /MT_A_Sk_MI_Admin_State	LCK, Normal	Normal
ODUKP-h /MT_A_Sk_MI_AIS_Period[1...M]	1 s, 1 min	1 s
ODUKP-h /MT_A_Sk_MI_AIS_CoS[1...M]	0 to 7	7
ODUKP-h /MT_A_Sk_MI_AIS_Tool[1...M]	[ITU-T G.8113.1], [ITU-T G.8113.2]	N/A
ODUKP-h /MT_A_Sk_MI_GAL_Enable[1...M]	True, false	(Note 4)
ODUKP-h/MT_A_Sk_MI_INCREASE	True, false	False
ODUKP-h/MT_A_Sk_MI_DECREASE	True, false	False
ODUKP-h/MT_A_Sk reporting		
ODUKP-h/MT_A_Sk_MI_AcPT (See Table 15-8 of [ITU-T G.709])	According to [ITU-T G.709] 0 to 255	N/A Not applicable

Table 8-2 – Provisioning and reporting for adaptation functions

MI signal	Value range	Default value
ODUkP-h/MT_A_Sk_MI_AcEXI (See Table 6-2 of [ITU-T G.7041])	0 to 255 According to [ITU-T G.709]	Not applicable N/A
ODUkP-h/MT_A_Sk_MI_LastInvalidUPI (See Table 6-3 of [ITU-T G.7041]) ODUkP-h/MT_A_Sk_MI_LastValidUPI	0 to 255 According to [ITU-T G.709]	Not applicable N/A
ETH/MT_A_So Provisioning		
ETH/MT_A_So_MI_Label[1...M]	16 to (2**20)-1	(Note 2)
ETH/MT_A_So_MI_LSPTType[1...M]	E-LSP, L-LSP	(Note 1)
ETH/MT_A_So_MI_CoS[1...M]	(Note 1)	(Note 1)
ETH/MT_A_So_PHB2TCMapping[1...M]	(Note 1)	(Note 1)
ETH/MT_A_So_MI_QoSEncodingMode[1...M]	A, B (Note 5)	(Note 2)
ETH/MT_A_So_MI_Mode[1...M]	Mode 1, Mode 2	Mode 1
ETH/MT_A_So_MI_Etype		
ETH/MT_A_Sk Provisioning		
ETH/MT_A_Sk_MI_Label[1...M]	16 to (2**20)-1	(Note 2)
ETH/MT_A_Sk_MI_LSPTType[1...M]	E-LSP, L-LSP	–
ETH/MT_A_Sk_MI_CoS[1...M]	0 to 7	–
ETH/MT_A_Sk_MI_TC2PHBMapping[1...M]	(Note 1)	(Note 1)
ETH/MT_A_Sk_MI_QoSDecodingMode[1...M]	A, B (Note 5)	(Note 1)
ETH/MT_A_Sk_MI_Mode[1...M]	Mode 1, Mode 2	Mode 1
ETH/MT_A_Sk_MI_LCK_Enable[1...M]	True, false	True
ETH/MT_A_Sk_MI_LCK_Period[1...M]	1 s, 1 min	1 s
ETH/MT_A_Sk_MI_LCK_CoS[1...M]	0 to 7	7
ETH/MT_A_Sk_MI_LCK_OAM_Tool[1...M]	[ITU-T G.8113.1], [ITU-T G.8113.2]	N/A
ETH/MT_A_Sk_MI_Admin_State	LCK, Normal	Normal
ETH/MT_A_Sk_MI_AIS_Enable[1...M]	True, false	True
ETH/MT_A_Sk_MI_AIS_Period[1...M]	1 s, 1 min	1 s
ETH/MT_A_Sk_MI_AIS_CoS[1...M]	0 to 7	7
ETH/MT_A_Sk_MI_AIS_OAM_Tool[1...M]	[ITU-T G.8113.1], [ITU-T G.8113.2]	N/A
<p>NOTE 1 – According to [ITU-T G.8121].</p> <p>NOTE 2 – A value must be provided at provisioning.</p> <p>NOTE 3 – Indicates ETH OAM related.</p> <p>NOTE 4 – MI_GAL_Enable must be set to true on LSPs and sections and to false on PWs. Setting it to true for PWs is for further study.</p> <p>NOTE 5 – See clause 8.2.1 of [ITU-T G.8121] for the semantic of A and B.</p>		

8.5.1 Adaptation – ITU-T G.8121.1 specific

For MT.NE that supports the adaptation functions specified in [ITU-T G.8121.1], the EMF shall in addition support the management of the MIs listed in Table 8-2.1.

Table 8-2.1 – Provisioning and reporting for adaptation functions

MI signal	Value range	Default value
MT/ETH_A_So Provisioning		
MT/ETH_A_So_MI_CSFdciEnable	True, false	False

8.5.2 Adaptation – ITU-T G.8121.2 specific

For MT.NE that supports the adaptation functions specified in [ITU-T G.8121.2], the EMF shall in addition support the management of the MIs listed in Table 8-2.2.

Table 8-2.2 – Provisioning and reporting for adaptation functions

MI signal	Value range	Default value
MT/MT_A_Sk Provisioning		
MT/MT_A_Sk_MI_Local_Defect	True, false	False
Sn/MT_A_Sk Provisioning		
Sn/MT_A_Sk_MI_Local_Defect	True, false	False
Sn-X-L/MT_A_Sk Provisioning		
Sn-X-L/MT_A_Sk_MI_Local_Defect	True, false	False
Sm/MT_A_Sk Provisioning		
Sm/MT_A_Sk_MI_Local_Defect	True, false	False
Sm-X-L/MT_A_Sk Provisioning		
Sm-X-L/MT_A_Sk_MI_Local_Defect	True, false	False
Pq/MT_A_Sk Provisioning		
Pq/MT_A_Sk_MI_Local_Defect	True, false	False
Pq-X-L/MT_A_Sk Provisioning		
Pq-X-L/MT_A_Sk_MI_Local_Defect	True, false	False
ODUKP/MT_A_Sk Provisioning		
ODUKP/MT_A_Sk_MI_Local_Defect	True, false	False
ODUKP-h/MT_A_Sk provisioning		
ODUKP-h/MT_A_Sk_MI_Local_Defect	True, false	False
ETH/MT_A_Sk Provisioning		
ETH/MT_A_Sk_MI_Local_Defect	True, false	False

8.6 Diagnostic

This clause provides the requirements for the management of the MT diagnostic trail termination functions (MTDe_TT)

For MT.NE that supports the MTDe_TT function specified in [ITU-T G.8121], the EMF shall support the following management functions for the MIs listed in Table 8-3:

- provisioning the trail termination management information;

- retrieving the trail termination management information;
- notifying the changes of the trail termination management information;
- receiving the monitored trail termination management information.

Table 8-3 – Provisioning and reporting for diagnostic trail termination function

MI signal	Value range	Default value
MTDe_TT_So Provisioning		
MTDe_TT_So_MI_GAL_Enable	True, false	(Note 3)
MTDe_TT_So_MI_TTLVALUE	0 to 255	255
MTDe_TT_So_MI_CV_OAM_Tool	[ITU-T G.8113.1], [ITU-T G.8113.2]	N/A
MTDe_TT_So_MI_CV_Series ()	See Tables 8-3.1 and 8-3.2 for the respective parameters and values	See Tables 8-3.1 and 8-3.2 for the respective parameters and values
MTDe_TT_So_MI_1TH_OAM_Tool	[ITU-T G.8113.1], [ITU-T G.8113.2]	N/A
MTDe_TT_So_MI_1TH_Start(CoS, Pattern, Length, Period) NOTE – Pattern is ITU-T G.8121.1 specific	Class of service (CoS): 0 to 7 Length: 0 to L The value of L depends on implementation, e.g., may be 2 ³² . Patterns, Period: for further study	Default value of Length: 0
MTDe_TT_So_MI_1TH_Terminate	–	–
MTDe_TT_So_MI_LMo_OAM_Tool	[ITU-T G.8113.1], [ITU-T G.8113.2]	N/A
MTDe_TT_So_MI_LMo_Start(CoS,Period) [1...M _{LMo}]	CoS: 0 to 7 Period: 100 ms, 1 s, 10 s	
MTDe_TT_So_MI_LMo_Intermediate_Request [1...M _{LMo}]	–	–
MTDe_TT_So_MI_LMo_Terminate[1...M _{LMo}]	–	–
MTDe_TT_So_MI_DMo_OAM_Tool	[ITU-T G.8113.1], [ITU-T G.8113.2]	N/A
MTDe_TT_So_MI_DMo_Start(CoS,Test_ID, Length,Period)[1...M _{DMo}]	CoS: 0 to 7 Test_ID: (Note 2) Length: 0 to L. The value of L depends on implementation, e.g., may be 2 ³² . Period: 1 s, 10 s, 1 min	Default value of Length: 0 Default value of Period: 1 min
MTDe_TT_So_MI_DMo_Terminate[1...M _{DMo}]	–	–
MTDe_TT_So_MI_1DMo_OAM_Tool	[ITU-T G.8113.1], [ITU-T G.8113.2]	N/A
MTDe_TT_So_MI_1DMo_Start(CoS,Test_ID, Length,Period)[1...M _{1DMo}]	CoS: 0 to 7 Test_ID: (Note 2) Length: 0 to L. The value of L depends on implementation, e.g., may be 2 ³² . Period: 100 ms, 1 s, 10 s	Default value of Length: 0
MTDe_TT_So_MI_DMo_Intermediate_Reques t[1...M _{LMo}]	–	–
MTDe_TT_So_MI_1DMo_Terminate [1...M _{1DMo}]	–	–

Table 8-3 – Provisioning and reporting for diagnostic trail termination function

MI signal	Value range	Default value
MTDe_TT_So_MI_SLo_OAM_Tool	[ITU-T G.8113.1], [ITU-T G.8113.2]	N/A
MTDe_TT_So_MI_SLo_Start(CoS,Test_ID, Length,Period)[1...M _{SLo}]	CoS: 0 to 7 Test_ID: (Note 2) Length: 0 to L. The value of L depends on implementation, e.g., may be 2 ³² . Period: 0.1 ms, 0.5 ms, 1 ms, 3.3 ms, 10 ms, 100 ms	Default value of Length: 0 Default value of Period: 10 ms
MTDe_TT_So_MI_SLo_Intermediate_Request [1...M _{LMo}]	–	–
MTDe_TT_So_MI_SLo_Terminate[1...M _{SLo}]	–	–
MTDe_TT_So_MI_Admin_State	LCK, Normal	Normal
MTDe_TT_So_MI_Lock_Instruct_Enable	True, false	True
MTDe_TT_So_MI_DP_Loopback_Enable	True, false	False
MTDe_TT_So Reporting		
MTDe_TT_So_MI_CV_Series_Result()	See Tables 8-3.1 and 8-3.2 for the respective parameters and values	See Tables 8-3.1 and 8-3.2 for the respective parameters and values
MTDe_TT_So_MI_1TH_Result(Sent)	–	–
MTDe_TT_So_MI_LMo_Result(N_TF,N_LF,F_TF,F_LF)[1...M _{LMo}]	–	–
MTDe_TT_So_MI_DMo_Result(count, B_FD[],F_FD[],N_FD[])[1...M _{DMo}]	–	–
MTDe_TT_So_MI_SLo_Result(N_TF,N_LF, F_TF,F_LF)[1...M _{SLo}]	–	–
MTDe_TT_Sk Provisioning		
MTDe_TT_Sk_MI_GAL_Enable	True, false	(Note 3)
MTDe_TT_Sk_MI_CV_OAM_Tool	[ITU-T G.8113.1], [ITU-T G.8113.2]	N/A
MTDe_TT_Sk_MI_1TH_OAM_Tool	[ITU-T G.8113.1], [ITU-T G.8113.2]	N/A
MTDe_TT_Sk_MI_1TH_Start(Pattern, Length, Period) NOTE – Pattern, length and period are ITU-T G.8121.1 specific	For further study	
MTDe_TT_Sk_MI_1TH_Terminate	–	–
MTDe_TT_Sk_MI_LMo_OAM_Tool	[ITU-T G.8113.1], [ITU-T G.8113.2]	N/A
MTDe_TT_Sk_MI_DMo_OAM_Tool	[ITU-T G.8113.1], [ITU-T G.8113.2]	N/A
MTDe_TT_Sk_MI_1DMo_OAM_Tool	[ITU-T G.8113.1], [ITU-T G.8113.2]	N/A
MTDe_TT_Sk_MI_1DMo_Start(Cos, Test_ID)[1...M _{1DMo}]	(Note 2)	–

Table 8-3 – Provisioning and reporting for diagnostic trail termination function

MI signal	Value range	Default value
MTDe_TT_Sk_MI_1DMo_Terminate [1...M _{1DMo}]	–	–
MTDe_TT_Sk_MI_SLo_OAM_Tool	[ITU-T G.8113.1], [ITU-T G.8113.2]	N/A
MTDe_TT_Sk_MI_DP_Loopback_Enable	True, false	False
MTDe_TT_Sk Reporting		
MTDe_TT_Sk_MI_1TH_Result(REC,CRC,BE R,OO)	–	–
MTDe_TT_Sk_MI_1DMo_Intermediate_Request[1...M _{1DMo}]	–	–
MTDe_TT_Sk_MI_1DMo_Result(count,N_FD [])[1...M _{DMo}]	–	–
MTDe_TT_Sk_MI_Admin_State_Request	Trigger to LCK, Trigger to Normal	–
MTDi_TT_So Provisioning		
MTDi_TT_So_MI_GAL_Enable	True, false	(Note 3)
MTDi_TT_So_MI_TTLVALUE	0 to 255	255
MTDi_TT_So_MI_MIP_ID	String; values are OAM protocol-specific	(Note 1)
MTDi_TT_So_MI_CV_OAM_Tool	[ITU-T G.8113.1], [ITU-T G.8113.2]	N/A
MTDi_TT_So_MI_DP_Loopback_Enable	True, false	False
MTDi_TT_Sk Provisioning		
MTDi_TT_Sk_MI_GAL_Enable	True, false	(Note 3)
MTDi_TT_Sk_MI_MIP_ID	String; values are OAM protocol-specific	(Note 1)
MTDi_TT_Sk_MI_CV_OAM_Tool	[ITU-T G.8113.1], [ITU-T G.8113.2]	N/A
MTDi_TT_Sk_MI_DP_Loopback_Enable	True, false	False
NOTE 1 – A value must be provided at provisioning.		
NOTE 2 – The Test ID field is optional when this proactive measurement tool is used.		
NOTE 3 – MI_GAL_Enable must be set to true on LSPs and sections and to false on PWs. Setting it to true for PWs is for further study.		

8.6.1 Diagnostic – ITU-T G.8121.1 specific

For MT.NE that supports the MTDe_TT function specified in [ITU-T G.8121.1], the EMF shall in addition support the management of the MIs listed in Table 8-3.1:

Table 8-3.1 – Provisioning and reporting for termination functions

MI signal	Value range	Default value
MTDe_TT_So Provisioning		
MTDe_TT_So_MI_CV_Series(CoS, N, Length, Period)	Time-to-live (TTL): 0 to 255 CoS: 0 to 7 N: 1 to n. The value of n depends on implementation, e.g., may be 2 ³² . Length: 0 to L. The value of L depends on implementation, e.g., may be 2 ³² . Period: 5 to 10 s.	Default value of N: 3 Default value of length: 0 Default value of period: 5 s.
MTDe_TT_So_MI_CV_Test(CoS, Pattern, Length, Period)	See [ITU-T G.8121.1]	
MTDe_TT_So Reporting		
MTDe_TT_So_MI_CV_Test_Result(Sent, REC, REC, ERR, OO)	See [ITU-T G.8121.1]	
MTDe_TT_So_MI_CV_Series_Result(REC, ERR, OO)	For further study	
MTDe_TT_Sk Provisioning		
MTDe_TT_Sk_MI_MEP_ID	See [ITU-T G.8121.1]	

8.6.2 Diagnostic – ITU-T G.8121.2 specific

For MT.NE that supports the MT_TT function specified in [ITU-T G.8121.2], the EMF shall in addition support the management of the MIs listed in Table 8-3.2:

Table 8-3.2 – Provisioning and reporting for termination functions

MI signal	Value range	Default value
MTDe_TT_So Provisioning		
MTDe_TT_So_MI_Target_FEC	See [ITU-T G.8121.2]	–
MTDe_TT_So_MI_CV_Series (Session_ID, Counter, Period, CoS, Size, ValidateFEC, ValidateReverse, TargetFECStack)	CoS: 0 to 7 To be defined for other parameters	8.10 CoS: 7 8.10 To be defined for other parameters
MTDe_TT_So_MI_CV_Trace(Session_ID, CoS, ValidateFEC, ValidateReverse, TargetFECStack)	CoS: 0 to 7 To be defined for other parameters	CoS: 7 To be defined for other parameters
MTDe_TT_So_MI_FEC_Checking	True, false	True
MTDe_TT_So_MI_DMo_Start(CoS, Test_ID, Length, Period, CopyPad)[1...M _{DMo}] (Note)	CoS: 0 to 7 Length: 0 to L. The value of L depends on implementation, e.g., may be 2 ³² . Period: 1 s, 10 s, 1 min CopyPad: True, false Test_ID: non-negative integer	

Table 8-3.2 – Provisioning and reporting for termination functions

MI signal	Value range	Default value
MTDe_TT_So_MI_LMo_Start(CoS, Test_ID, Period, LMType, CountBytes)[1...MLMo] (Note)	CoS: 0 to 7 Period: 1 s, 10 s, 1 min LMType: ILM, DLM CountBytes: True, false Test_ID: non-negative integer	
MTDe_TT_So_MI_LMDMo_Start(CoS, Test_ID, Length, Period, LMType, CountBytes, CopyPad)[1...MLMDMo]	CoS: 0 to 7 Length: 0 to L. Period: 1 s, 10 s, 1 min LMType: ILM, DLM CountBytes: True, false CopyPad: True, false Test_ID: non-negative integer	
MTDe_TT_So_MI_LMDMo_Terminate [1...MLMDMo]	–	
MTDe_TT_So_MI_LI_Period	1, 255	1
MTDe_TT_So_MI_LI_MEPID	0 to 255	255
MTDe_TT_So_MI_LI_CoS	0, 1, 2, 3, 4, 5, 6, 7	7
MTDe_TT_So Reporting		
MTDe_TT_So_MI_CV_Series_Result(Session_ID, Rev, CoS, OOO, FWErr, BWErr)	To be defined	–
MTDe_TT_So_MI_CV_Trace_Result (Session_ID, Result)	To be defined	–
MTDe_TT_So_MI_CV_BWErr(Session_ID, Seq, RC, SubRC, ErrTLV)	To be defined	–
MTDe_TT_So_MI_CV_BWErr(Session_ID, Seq, RC, SubRC, ErrTLV)	To be defined	–
MTDe_TT_So_MI_DMo_ReportError(Error) [1...MDMo]	True, false	
MTDe_TT_So_MI_DMo_PeriodChanged [1...MDMo]	True, false	
MTDe_TT_So_MI_LMo_ReportError(Error) [1...MLMo]	True, false	
MTDe_TT_So_MI_LMo_PeriodChanged [1...MLMo]	True, false	
MTDe_TT_Sk Provisioning		
MTDe_TT_Sk_MI_PM_Responder_Enable	True, false	False
MTDe_TT_Sk_MI_FEC_Checking	True, false	True
MTDe_TT_Sk Reporting		
MTDi_TT_So Provisioning		
MTDi_TT_So_MI_Target_FEC	See [ITU-T G.8121.2]	–
MTDi_TT_So_MI_Ifnun	See [ITU-T G.8121.2]	–

Table 8-3.2 – Provisioning and reporting for termination functions

MI signal	Value range	Default value
MTDi_TT_So_MI_MTU	See [ITU-T G.8121.2]	–
MTDi_TT_Sk Provisioning		
MTDi_TT_Sk_MI_FEC_Checking	See [ITU-T G.8121.2]	–
NOTE – These MI signals are defined in MTDe_TT_So in [ITU-T G.8121] and [ITU-T G.8121.2] does not use these MI signals as defined in Table 8-3 in this Recommendation.		

8.7 Connection

See clause 8.6 of [ITU-T G.7710] for a description of connection management.

This function allows a user to provision the operation of a MPLS-TP connection process.

The MI signals, listed in this clause, are communicated from the EMF to the connection process through the management point.

For MT.NE that supports the MT_C and MTp_C functions specified in [ITU-T G.8121], the EMF shall support the following management functions for the MIs listed in Table 8-4:

- provisioning the trail termination management information;
- retrieving the trail termination management information;
- notifying the changes of the trail termination management information.

Table 8-4 – Provisioning and reporting for connection functions

MI signal	Value range	Default value
MT_C Provisioning (per matrix connection)		
MT_C_MI_ConnectionType	Protected, unprotected	Unprotected
MT_C_MI_Return_CP_ID	NULL (for unidirectional), or the connection point (CP) identifier (for bidirectional)	–
MT_C_MI_ConnectionPortIds	Set of CP identifiers	–
MT_C Provisioning		
MT_C_MI_MatrixControl	Connect, disconnect	N/A
MT_C Provisioning (per protection process)		
MT_C_MI_PS_WorkingPortId	(Note)	(Note)
MT_C_MI_PS_ProtectionPortId	(Note)	(Note)
MT_C_MI_PS_ProfType	(Note)	(Note)
MT_C_MI_PS_OperType	(Note)	(Note)
MT_C_MI_PS_HoTime	(Note)	(Note)
MT_C_MI_PS_WTR	(Note)	(Note)
MT_C_MI_PS_ExtCMD	(Note)	(Note)
MT_C_MI_PS_SD_Protection	Disabled, enabled	Disabled
MTp_C Provisioning (per protection process)		
MT_C_MI_PS_WorkingPortId	(Note)	(Note)

Table 8-4 – Provisioning and reporting for connection functions

MI signal	Value range	Default value
MT_C_MI_PS_ProtectionPortId	(Note)	(Note)
MT_C_MI_PS_ProfType	(Note)	(Note)
MT_C_MI_PS_OperType	(Note)	(Note)
MT_C_MI_PS_HoTime	(Note)	(Note)
MT_C_MI_PS_WTR	(Note)	(Note)
MT_C_MI_PS_ExtCMD	(Note)	(Note)
MT_C_MI_PS_SD_Protection	Disabled, enabled	Disabled
MSRP_C Provisioning (per ring protection process)		
MI_MSRRP_EastPort	(Note)	(Note)
MI_MSRRP_WestPort	(Note)	(Note)
MI_MSRRP_ProfType	(Note)	(Note)
MI_MSRRP_HoTime	(Note)	(Note)
MI_MSRRP_WTR	(Note)	(Note)
MI_MSRRP_ExtCMD	(Note)	(Note)
NOTE – According to [ITU-T G.8121].		

8.7.1 Connection – ITU-T G.8121.1 specific

For MT.NE that supports the MT_C functions specified in [ITU-T G.8121.1], there is no additional MI to be managed beyond those listed in Table 8-4.

8.7.2 Connection – ITU-T G.8121.2 specific

For MT.NE that supports the MT_C functions specified in [ITU-T G.8121.2], there is no additional MI to be managed beyond those listed in Table 8-2.

8.8 Degraded (DEG) thresholds

For further study.

8.9 XXX_Reported

See clause 8.8 of [ITU-T G.7710] for a description of XXX_Reported management.

8.10 Alarm severity

See clause 8.9 of [ITU-T G.7710] for a description of alarm severity.

8.11 Alarm reporting control

See clause 8.10 of [ITU-T G.7710] for a description of alarm report control.

8.12 PM thresholds

For further study.

8.13 TCM activation

For further study.

8.14 Date and time

The date and time functions within the MPLS-TP EMF comprise the local real time clock (RTC) function and the performance monitoring clock (PMC) function. The message communication function within the MPLS-TP NEF shall be capable of setting the local RTC function.

The date and time values are incremented by a free-running local clock, or by an external timing source. The fault management, configuration management, account management, performance management and security management (FCAPS) functions need date and time information, e.g., to time stamp event reports. They obtain this information from the date and time function.

8.14.1 Date and time applications

Clause 8.13.1 of [ITU-T G.7710] identifies three date and time applications. These are:

- 1) time-stamping;
- 2) performance monitoring clock signals;
- 3) activity scheduling.

The MPLS-TP NEF functional requirements for these applications are specified in the following clauses.

8.14.1.1 Time-stamping

See clause 8.13.1.1 of [ITU-T G.7710] for a description of the time-stamping application.

8.14.1.2 Performance monitoring clock signals

See clause 8.13.1.2 of [ITU-T G.7710] for a description of the PMC signals.

8.14.1.3 Activity scheduling

See clause 8.13.1.3 of [ITU-T G.7710] for a description of the activity scheduling.

8.14.2 Date and time functions

[See clause 8.13.2 of \[ITU-T G.7710\] for a description of the date and time application.](#)

~~There are three date and time functions defined. The local RTC function is required for time stamping and activity scheduling. The local RTC alignment function is required for aligning the clock with an external time reference. The PMC function, in addition to RTC, is typical for digital counter measurements.~~

8.14.2.1 Local RTC function

The local RTC function is specified in clause 8.13.2.1 of [ITU-T G.7710].

8.14.2.2 Local RTC alignment function with external time reference

The local RTC alignment function with external time reference is specified in clause 8.13.2.2 of [ITU-T G.7710].

8.14.2.3 Performance monitoring clock function

The performance monitoring clock function is specified in clause 8.13.2.3 of [ITU-T G.7710].

9 Accounting management

For further study.

10 Performance management

See clause 10 of [ITU-T G.7710] for the generic requirements for performance management. MPLS-TP specific management requirements are described below.

10.1 Performance management applications

See clause 10.1 of [ITU-T G.7710] for the generic description for performance management applications.

10.2 Performance monitoring functions

See clause 10.2 of [ITU-T G.7710] for generic requirements of performance monitoring functions.

The following are MPLS-TP specific performance management requirements:

- 1) PM measurements are managed at trail termination points (TTPs) and connection termination points (CTPs) (i.e., MEPs/MIPs are created and deleted).
- 2) One MEP has to be created per TTP if that has to be supervised.
- 3) Two types of measurement jobs have to be supported (proactive, on-demand).
- 4) Proactive measurement jobs are managed at MEPs (establish, disable, enable, terminate).
- 5) On-demand measurement jobs are managed at MEPs (establish, modify, abort).
- 6) On-demand measurements can be done using four different OAM PDU generation mechanisms: single instance, repetitive instance, single series and repetitive series. To describe these mechanisms, the following terms are used:
 - OAM PDU generation type:
generation pattern of the on-demand OAM message.
valid types are: single instance, repetitive instance, single series and repetitive series.
 - Message period (x)
frequency of the OAM message generation within a series.
note that a value of zero (i.e., $x = 0$) means that only one OAM message per measurement interval is generated.
 - Measurement interval (y)
defines discrete non-overlapping periods of time during which measurements are performed (i.e., OAM messages are generated) and reports are gathered at the end of the measurement intervals.
note that a value of zero means a degenerated measurement interval with a single OAM message and the report is sent as immediately as possible.
 - Repetition period (z)
defines the time between the start of two measurement intervals;
this IS applicable for the repetitive instance type and MAY be applicable for the repetitive series type.
note that a value of zero means not applicable (N/A). This is for the cases of single instance, single series, or repetitive series without extra gap in between the measurement intervals (i.e., also as known as continuous series).
 - Start time
defines the start of the on-demand session.
 - Stop time
defines the stop of the on-demand session.

- Session duration

stop time – start time.

note that session duration is not a configuration parameter. That is, it is not needed in the configuration.

The four on-demand measurements are illustrative in Figure 10-1 of [ITU-T G.8051].

Note that in the repetitive series case, if the repetition period $z = y + x$, or the value is not provisioned, then there is no extra gap between the end of the measurement interval and the start of the new measurement interval. This pattern is also known as the continuous series cases. The repetition period (z) is needed if there is extra gap between the measurement intervals.

- 7) It shall be possible to configure the following on-demand measurement parameters (including the default values):
 - a) OAM PDU generation type; default = repetitive instance;
 - b) Start time; default = current time;
 - c) Stop time; default = current time + 1 hour;
 - d) OAM message period; default = 0;
 - e) Measurement interval; default = 0;
 - e) Repetition period; default = 0.
- 8) Parallel measurement jobs, one per priority, can be established.
- 9) Performance data is stored in registers associated to the measurement job.
- 10) On-demand measurement jobs are automatically terminated after (last) report is sent.
- 11) Threshold profiles are managed at the managed element (create, modify, delete)
- 12) It shall be possible to retrieve the following configuration information:
 - a) All existing MEPs/MIPs within a TP (TTP or CTP);
 - b) All existing measurement jobs within a MEP;
 - c) All existing threshold profiles within a network element;
 - d) All threshold settings within a proactive PM measurement job.
- 13) It shall be possible to retrieve all proactive PM measurement current and history performance data within a MEP.
- 14) It shall be possible to request intermediate reports on an on-demand PM measurement job of "single series" and "repetitive series" types.
- 15) It shall be possible to request an autonomous continuous reporting of performance data from all proactive PM measurement jobs within a MEP (i.e., automatic "push" of the measured PM data).
- 16) On-demand loss measurement can be measured by directly counting the data traffic or can be inferred by counting the synthetic traffic. If on-demand loss measurement is supported, for each measurement interval, the MPLS-TP NE should:
 - Receive from the transport plane the measurements (i.e., N_TF, N_LF, F_TF, F_LF) at the end of each measurement interval.

According to the definition of near-end and far-end frame loss in clause 8.1 of [ITU-T G.8013], for a MEP, N_TF and N_LF refer to the transmitted and lost ingress frames while F_TF and F_LF refer to the transmitted and lost egress frames.

Note that one-way synthetic loss (1SL) can provide only near-end measurement (i.e., N_TF, N_LF).

- Store the measurements (TN_TF, TN_LF, TF_TF, TF_LF) and calculate the frame loss ratios (FLRs) ($TN_FLR = TN_LF / TN_TF$, $TF_FLR = TF_LF / TF_TF$). The measurements and FLRs shall be reported to the management system.
- At the instruction of the management system, the NE shall be able to request from the transport plane the intermediate (i.e., before the end of the Measurement Interval) measurements, calculate the intermediate FLRs, and report the intermediate results (TN_TF, TN_LF, TN_FLR, TF_TF, TF_LF, TF_FLR) to the management system.

NOTE – An on-demand loss measurement (LM) or delay measurement (DM) session could be a single series of OAM messages or a single instance of OAM message. A single instance OAM could be considered as a special case of a single series OAM.

- 17) Proactive loss measurement can be measured by directly counting the data traffic or can be inferred by counting the synthetic traffic. If proactive loss measurement is supported, for each loss measurement session the MPLS-TP NE should:
- Receive from the transport plane the measurements (i.e., pN_TF, pN_LF, pF_TF, pF_LF) for each OAM period.
Note that 1SL can support only near-end measurement (i.e., N_TF, N_LF).
 - Calculate the FLRs ($N_FLR = pN_LF / pN_TF$, $F_FLR = pF_LF / pF_TF$) for each OAM period; store the temporal minimum, average and maximum statistics (mN_FLR, aN_FLR, xN_FLR, mF_FLR, aF_FLR, xF_FLR) in the current 15-minute and 24-hour registers. The stored statistics shall be available for retrieval by the management system.
 - The FLR measurements of a monitored entity measured during severely errored seconds (SES) shall be included in the computation of its FLR statistics, unless the SES is part of the unavailable time period.
NOTE – This is in line with the definition made in Note 1 of clause 1 in [ITU-T Y.1563].
 - At the maturity of the current 15-minute and 24-hour periods, the statistics in the current registers shall move to the history registers and then reset the current registers to zeros. See detailed requirements in [ITU-T G.7710].
- 18) If on-demand 1-way DM is supported, for each on-demand 1-way DM measurement interval, the MPLS-TP NE should:
- Receive from the transport plane the array of near-end measurements (count, N_FD[]) at the end of each measurement interval.
 - Store the measurements, compute the corresponding array of N_FD[] and report the near-end measurements (count, N_FD[], N_FD[]) to the management system.
 - At the instruction of the management system, the NE shall be able to request from the transport plane the intermediate measurements, calculate the intermediate N_FD[], and report the intermediate results (count, N_FD[], N_FD[]) to the management system.
- 19) If proactive 1-way DM is supported, for each proactive 1-way DM session the MPLS-TP NE should:
- Receive from the transport plane the near-end measurements (pN_FD, pN_FD) for each OAM period.
 - Store the temporal minimum, average and maximum (N_FD, N_FD) in the current 15-minute and 24-hour registers. The stored statistics shall be available for retrieval by the management system.
 - At the maturity of the current 15-minute and 24-hour periods, the statistics in the current registers shall move to the history registers and then reset the current registers to zeros. See detailed requirements in [ITU-T G.7710].

- 20) If on-demand 2-way DM is supported, for each on-demand 2-way DM measurement interval, the MPLS-TP NE should:
- Receive from the transport plane the array of near-end, far-end and bidirectional measurements (count, N_FD[], F_FD[], B_FD[]) at the end of each measurement interval.
 - Store the measurements, compute the corresponding array of FDV[], and report the near-end, far-end, and bidirectional (2-way) measurements (count, N_FD[], F_FD[], B_FD[]; N_FDV[], F_FDV[], B_FDV[]) to the management system.
 - At the instruction of the management system, the NE shall be able to request from the transport plane the intermediate measurements, calculate the intermediate FDV[], and report the intermediate results (count, N_FD[], F_FD[], B_FD[]; N_FDV[], F_FDV[], B_FDV[]) to the management system.
- 21) If proactive 2-way DM is supported, for each proactive 2-way DM session the MPLS-TP NE should:
- Receive from the transport plane the near-end, far-end and bidirectional measurements (N_FD, F_FD, B_FD; N_FDV, F_FD, B_FD) for each OAM period.
 - Store the temporal minimum, average and maximum for each type of the measurements (N_FD, F_FD, B_FD; N_FD, F_FD, B_FD) for the current 15-minute and 24-hour registers. The stored statistics shall be available for retrieval by the management system.
 - At the maturity of the current 15-minute and 24-hour periods, the statistics in the current registers shall move to the history registers and then reset current registers to zeros. See detailed requirements in [ITU-T G.7710].
- 22) The MPLS-TP NE should support the ability to configure for the start and stop at the respondent-end MEP of a single-ended measurement session.

MPLS-TP NE shall provide the following PM management information (see Table 10-1).

Table 10-1 – PM management information

PM management information	ITU-T G.8121 function
MT_TT_Sk_MI_pN_LF	MT_TT_Sk
MT_TT_Sk_MI_pN_TF	
MT_TT_Sk_MI_pF_LF	
MT_TT_Sk_MI_pF_TF	
MT_TT_Sk_MI_pF_DS	
MT_TT_Sk_MI_pN_DS	
MT_TT_Sk_MI_pB_FD	
MT_TT_Sk_MI_pB_FD	
MT_TT_Sk_MI_pN_FD	
MT_TT_Sk_MI_pN_FD	
MT_TT_Sk_MI_pF_FD	
MT_TT_Sk_MI_pF_FD	
MT/ETH_A_Sk_MI_pFCSErrors	

The EMF shall support the following functions:

- notifying of the PM management information.

11 Security management

See [ITU-T G.7710] for a description of security management.

Bibliography

- [b-IETF RFC 5951] IETF RFC 5951 (2010), *Network Management Requirements for MPLS-based Transport Networks*.

ITU-T Y-SERIES RECOMMENDATIONS

GLOBAL INFORMATION INFRASTRUCTURE, INTERNET PROTOCOL ASPECTS, NEXT-GENERATION NETWORKS, INTERNET OF THINGS AND SMART CITIES

GLOBAL INFORMATION INFRASTRUCTURE	
General	Y.100–Y.199
Services, applications and middleware	Y.200–Y.299
Network aspects	Y.300–Y.399
Interfaces and protocols	Y.400–Y.499
Numbering, addressing and naming	Y.500–Y.599
Operation, administration and maintenance	Y.600–Y.699
Security	Y.700–Y.799
Performances	Y.800–Y.899
INTERNET PROTOCOL ASPECTS	
General	Y.1000–Y.1099
Services and applications	Y.1100–Y.1199
Architecture, access, network capabilities and resource management	Y.1200–Y.1299
Transport	Y.1300–Y.1399
Interworking	Y.1400–Y.1499
Quality of service and network performance	Y.1500–Y.1599
Signalling	Y.1600–Y.1699
Operation, administration and maintenance	Y.1700–Y.1799
Charging	Y.1800–Y.1899
IPTV over NGN	Y.1900–Y.1999
NEXT GENERATION NETWORKS	
Frameworks and functional architecture models	Y.2000–Y.2099
Quality of Service and performance	Y.2100–Y.2199
Service aspects: Service capabilities and service architecture	Y.2200–Y.2249
Service aspects: Interoperability of services and networks in NGN	Y.2250–Y.2299
Enhancements to NGN	Y.2300–Y.2399
Network management	Y.2400–Y.2499
Network control architectures and protocols	Y.2500–Y.2599
Packet-based Networks	Y.2600–Y.2699
Security	Y.2700–Y.2799
Generalized mobility	Y.2800–Y.2899
Carrier grade open environment	Y.2900–Y.2999
FUTURE NETWORKS	Y.3000–Y.3499
CLOUD COMPUTING	Y.3500–Y.3999
INTERNET OF THINGS AND SMART CITIES AND COMMUNITIES	
General	Y.4000–Y.4049
Definitions and terminologies	Y.4050–Y.4099
Requirements and use cases	Y.4100–Y.4249
Infrastructure, connectivity and networks	Y.4250–Y.4399
Frameworks, architectures and protocols	Y.4400–Y.4549
Services, applications, computation and data processing	Y.4550–Y.4699
Management, control and performance	Y.4700–Y.4799
Identification and security	Y.4800–Y.4899
Evaluation and assessment	Y.4900–Y.4999

For further details, please refer to the list of ITU-T Recommendations.

SERIES OF ITU-T RECOMMENDATIONS

Series A	Organization of the work of ITU-T
Series D	Tariff and accounting principles and international telecommunication/ICT economic and policy issues
Series E	Overall network operation, telephone service, service operation and human factors
Series F	Non-telephone telecommunication services
Series G	Transmission systems and media, digital systems and networks
Series H	Audiovisual and multimedia systems
Series I	Integrated services digital network
Series J	Cable networks and transmission of television, sound programme and other multimedia signals
Series K	Protection against interference
Series L	Environment and ICTs, climate change, e-waste, energy efficiency; construction, installation and protection of cables and other elements of outside plant
Series M	Telecommunication management, including TMN and network maintenance
Series N	Maintenance: international sound programme and television transmission circuits
Series O	Specifications of measuring equipment
Series P	Telephone transmission quality, telephone installations, local line networks
Series Q	Switching and signalling, and associated measurements and tests
Series R	Telegraph transmission
Series S	Telegraph services terminal equipment
Series T	Terminals for telematic services
Series U	Telegraph switching
Series V	Data communication over the telephone network
Series X	Data networks, open system communications and security
Series Y	Global information infrastructure, Internet protocol aspects, next-generation networks, Internet of Things and smart cities
Series Z	Languages and general software aspects for telecommunication systems

