

**Question(s):** 14/15

Geneva, 20 November – 1 December 2023

TD**Source:** Editors G.8152**Title:** Draft revision to ITU-T G.8152 “Protocol-neutral management information model for the MPLS-TP network element”, v3.0 for consent**Contact:** Kam LAM
CICT
China
Tel: +1 732-275-4646
Email: kam.lam@fhusainc.com**Contact:** Scott Mansfield
Ericsson
Canada
Tel: +1 724 931 9316
Email: scott.mansfield@ericsson.com**Abstract:** The document contains the editor draft of revision to Recommendation G.8152 “Protocol-neutral management information model for the MPLS-TP network element”, v3.0 for consent.**Document history:**

Version	Date	Description
2.01	WD14-14 (09/2019) TD485/WP3 (1/2020)	The first created based on the published G.8152 Edition 2 (12/2018) with the following updates: <ul style="list-style-type: none">– 7.3.1 and 7.3.2 on the description of LM and DM To Do: <ul style="list-style-type: none">– Per C1304 proposal #2– Per C1234
2.02	TD485R1/WP3 (2/2020)	Updates: <ul style="list-style-type: none">– Align UML diagram artifacts to the background grip (Not completed yet):<ul style="list-style-type: none">○ Fig 6-4 High-level TP containment○ Figure 6-5 TP inheritance

Version	Date	Description
2.03	TD712/WP3 (04/2021)	<p>Updates:</p> <ul style="list-style-type: none"> – Rename the UML module from ItutG8152 to itut-mpls-tp-mgmt – Update the Open Model Statement (including urn:itu:t:rec:mpls-tp-ne-mgmt:uml:itut-mpls-tp-mgmt) and Reference of the module – Add the suffix _D to the names of the existing object classes and also shorten the names by using abbreviations (e.g., Mt, Tp, Ttp, Ctp, Mea, Snc, Sn, Raps, etc.) – Prune/Refactor MT TTP – Update clause 8 <p>To do:</p> <ul style="list-style-type: none"> – MT_CTP has duplicated attribute – ClientLayerSpecificAdaptationMi_Pac is empty – Tp_Pac to be completed – SeverLayerSpecificAdaptationMi_Pac is empty – MT_TTP has mt_CTP attribute – currentProblemList – OnDemandDualEndedMeasurementJobControlSink has duplicated attributes: startTime, stopTime, testIdentifier – Remove isSfProtectionEnable from linear PS. SF is always used as a trigger for linear protection switching
2.04	CD14a-08 (11/2021) TD844/WP3 (12/2021)	<p>Update the document structure according to CD14a-24. Update to CD14a-08 for TD/WP3: Add placeholder clause 7.5.2 for ring protection; Add editor notes in Annex A; Add “?” to TP Pool in Fig. 6-2 to note the need of investigation.</p>
	TD844r1/3 (2021-12-15)	<p>To be updated per agreement on C2647: To adopt the Ethernet performance monitoring model as the pattern for updating the performance monitoring fragment of the G.8152 UML model. Pending on the progress of G.8052.1 and TCIM.</p>
2.0.5	CD14c-07 (7/2022)	<p>Update</p> <ul style="list-style-type: none"> – Up-version modeling tool to Eclipse 2020-06 (4.16) & Papyrus 4.8. Clause 8 contains the updated UML files in cd14c-07_G.8152_v2.0.5_uml@2022-07-19.zip.
	CD14c-07r1 (8/2022)	<p>Update</p> <ul style="list-style-type: none"> – Summary for the 2023 Revision. – Clause 2 References
	TD43/WP3 (2022-09)	

Version	Date	Description
2.0.6	TD176/WP3 (2023-04)	Update <ul style="list-style-type: none"> – Renames the uml model name from itut-mpls-tp-mgmt to itut-mpls-tp – Open model statement – Per agreement in WD14-07r2 from discussion of C517 <ul style="list-style-type: none"> ○ Figure 7-5
2.0.7	WD1214-46 (2023.09) <i>Aim for TD/PLEN (11/2023) for consent</i>	Updates: <ul style="list-style-type: none"> – New MtCtp, MtCtpPac, MtCtpSourcePac, MtCtpSinkPac, MtCtpBidirPac (see Figure 7-1.A) – New MtTtp, MtTtpPac, MtTtpSourcePac, MtTtpSinkPac, MtTtpBidirPac (see Figure 7-1.B)
3.0 → 2.0.8	TD236/P (11/2023) for consent	Updates <ul style="list-style-type: none"> – Up versioned the UML model to v3.0 and update the Open Model Statement – Dates of references
2.0.9	TD236R1/P (12/2023) for consent, wd14-69	Updates per C709 terminologies <ul style="list-style-type: none"> – Clause 3.1 <p>Updates per decision on C711R1</p> <ul style="list-style-type: none"> – Clause 7.1.1 MT CTP, – Clause 7.1.2 MT TTP, – Clause 7.1.3 MT connectivity, – Clause 7.1.4 MT multiplexing, <p>Updates per 2023.11.26 Sunday drafting session (see wd14-11_2023.11.26-drafting_Editing-instructions)</p> <ul style="list-style-type: none"> – Add Clause 7.1.5 MT TP auxiliary object classes – Replace the content of Annex A with the text of Clause 7 of the 2018 edition of G.8152 (i.e., the version 2 MT model) – Drop the Y series recommendation number – Renumber the figures, e.g., 7-9.A, .B, ...; A-1, A-2,)

I n t e r n a t i o n a l T e l e c o m m u n i c a t i o n U n i o n

ITU-T

TELECOMMUNICATION
STANDARDIZATION SECTOR
OF ITU

G.8152

(xx/2024)

SERIES G: TRANSMISSION SYSTEMS AND MEDIA,
DIGITAL SYSTEMS AND NETWORKS

Packet over Transport aspects – MPLS over Transport
aspects

SERIES Y: GLOBAL INFORMATION
INFRASTRUCTURE, INTERNET PROTOCOL ASPECTS,
NEXT-GENERATION NETWORKS, INTERNET OF
THINGS AND SMART CITIES

Internet protocol aspects – Transport

**Protocol-neutral management information
model for the MPLS-TP network element**

Recommendation ITU-T G.8152

ITU-T G-SERIES RECOMMENDATIONS
TRANSMISSION SYSTEMS AND MEDIA, DIGITAL SYSTEMS AND NETWORKS

INTERNATIONAL TELEPHONE CONNECTIONS AND CIRCUITS	G.100–G.199
GENERAL CHARACTERISTICS COMMON TO ALL ANALOGUE CARRIER-TRANSMISSION SYSTEMS	G.200–G.299
INDIVIDUAL CHARACTERISTICS OF INTERNATIONAL CARRIER TELEPHONE SYSTEMS ON METALLIC LINES	G.300–G.399
GENERAL CHARACTERISTICS OF INTERNATIONAL CARRIER TELEPHONE SYSTEMS ON RADIO-RELAY OR SATELLITE LINKS AND INTERCONNECTION WITH METALLIC LINES	G.400–G.449
COORDINATION OF RADIOTELEPHONY AND LINE TELEPHONY	G.450–G.499
TRANSMISSION MEDIA AND OPTICAL SYSTEMS CHARACTERISTICS	G.600–G.699
DIGITAL TERMINAL EQUIPMENTS	G.700–G.799
DIGITAL NETWORKS	G.800–G.899
DIGITAL SECTIONS AND DIGITAL LINE SYSTEM	G.900–G.999
MULTIMEDIA QUALITY OF SERVICE AND PERFORMANCE – GENERIC AND USER-RELATED ASPECTS	G.1000–G.1999
TRANSMISSION MEDIA CHARACTERISTICS	G.6000–G.6999
DATA OVER TRANSPORT – GENERIC ASPECTS	G.7000–G.7999
PACKET OVER TRANSPORT ASPECTS	G.8000–G.8999
Ethernet over Transport aspects	G.8000–G.8099
MPLS over Transport aspects	G.8100–G.8199
Synchronization, quality and availability targets	G.8200–G.8299
Service Management	G.8600–G.8699
ACCESS NETWORKS	G.9000–G.9999

For further details, please refer to the list of ITU-T Recommendations.

Recommendation ITU-T G.8152

Protocol-neutral management information model for the MPLS-TP network element

Summary

Recommendation ITU-T G.8152 contains the protocol neutral unified modelling language (UML) model for multi-protocol label switching – transport profile (MPLS-TP) network element (NE) management.

This Recommendation provides a representation of the MPLS-TP technology using the methodologies that have been used for other transport technologies (e.g., SDH, OTN and Ethernet).

The 2018 revision of this Recommendation up-versions the UML model tool to Papyrus v3.2.0 and the profile to v0.2.13, updates the model to add the MEP proactive measurement MI, MEP configuration MI and MIP configuration MI, adds the Spec model for MPLS-TP model, replaces the G.8152NE and MT_NE with the MMPLS-TP constraint domain, and MT_SubnetworkProtectionGroup specifies the FcSwitch, and MT_CrossConnection specifies the ForwardingConstruct.

Edition 3.0 of this Recommendation updates the MPLS-TP model to prune and refactor the TTP, CTP, Connectivity, Auxiliary MEP and MIP object classes from the G.7711 core model object classes, and up-versions the modelling tool to Eclipse 2020-06 (4.16) & Papyrus 4.8.

History

Edition	Recommendation	Approval	Study Group	Unique ID*
1.0	ITU-T G.8152/Y.1375	2016-12-22	15	11.1002/1000/13104
2.0	ITU-T G.8152/Y.1375	2018-12-14	15	11.1002/1000/13799
3.0	ITU-T G.8152	2024-xx-xx	15	

Keywords

Information model, MPLS-TP, protocol-neutral, transport resource, UML.

* To access the Recommendation, type the URL <http://handle.itu.int/> in the address field of your web browser, followed by the Recommendation's unique ID. For example, <http://handle.itu.int/11.1002/1000/1830-en>.

FOREWORD

The International Telecommunication Union (ITU) is the United Nations specialized agency in the field of telecommunications, information and communication technologies (ICTs). The ITU Telecommunication Standardization Sector (ITU-T) is a permanent organ of ITU. ITU-T is responsible for studying technical, operating and tariff questions and issuing Recommendations on them with a view to standardizing telecommunications on a worldwide basis.

The World Telecommunication Standardization Assembly (WTSA), which meets every four years, establishes the topics for study by the ITU-T study groups which, in turn, produce Recommendations on these topics.

The approval of ITU-T Recommendations is covered by the procedure laid down in WTSA Resolution 1.

In some areas of information technology which fall within ITU-T's purview, the necessary standards are prepared on a collaborative basis with ISO and IEC.

NOTE

In this Recommendation, the expression "Administration" is used for conciseness to indicate both a telecommunication administration and a recognized operating agency.

Compliance with this Recommendation is voluntary. However, the Recommendation may contain certain mandatory provisions (to ensure, e.g., interoperability or applicability) and compliance with the Recommendation is achieved when all of these mandatory provisions are met. The words "shall" or some other obligatory language such as "must" and the negative equivalents are used to express requirements. The use of such words does not suggest that compliance with the Recommendation is required of any party.

INTELLECTUAL PROPERTY RIGHTS

ITU draws attention to the possibility that the practice or implementation of this Recommendation may involve the use of a claimed Intellectual Property Right. ITU takes no position concerning the evidence, validity or applicability of claimed Intellectual Property Rights, whether asserted by ITU members or others outside of the Recommendation development process.

As of the date of approval of this Recommendation, ITU had not received notice of intellectual property, protected by patents, which may be required to implement this Recommendation. However, implementers are cautioned that this may not represent the latest information and are therefore strongly urged to consult the TSB patent database at <http://www.itu.int/ITU-T/ipr/>.

© ITU 2019

All rights reserved. No part of this publication may be reproduced, by any means whatsoever, without the prior written permission of ITU.

Table of Contents

Page

Introduction

This Recommendation contains the object classes for the MPLS-TP NE management. It includes the termination points (TP), maintenance entity group (MEG) end point (MEP), MEG intermediate point (MIP), traffic conditioning and shaping (TCS), loss measurement (LM), delay measurement (DM), and the general performance monitoring (PM) current data (CD) and history data (HD).

The TP, MEP, MIP, LM, DM, and TCS object classes support the configuration and fault management functions as specified in [ITU-T G.8151].

The MPLS-TP TPs are modelled as subclasses of the generic GlobalClass defined in [ITU-T G.7711] and extending the LTP and LP classes of [ITU-T G.7711].

The MPLS-TP general PM CD and HD object classes are modelled as subclasses of the generic current data and history data defined in [ITU-T Q.822].

The MPLS-TP general CD and HD object classes support only the quality of service (QoS) directly related PM parameters, i.e., severely errored second (SES) and unavailable second (UAS), for service level agreement (SLA) verification. The additional PM object classes for supporting loss measurement and delay measurement monitoring uses the general CD and HD object classes as super classes.

The object model defined in this Recommendation is protocol-neutral with respect to management protocols. The model could be used as the base for further defining the information model for any specific management protocol.

The model in this Recommendation has been specified using the open source UML modelling tool "Papyrus".

Recommendation ITU-T G.8152

Protocol-neutral management information model for the MPLS-TP network element

1 Scope

This Recommendation provides a management/control-protocol-neutral information model for managing/controlling network elements in the MPLS-TP transport network as defined in [ITU-T G.8110.1]. It identifies the managed entities required for the management/control of MPLS-TP transport network elements. These entities are relevant to information exchanged across standardized interfaces defined in the [ITU-T M.3010] TMN architecture. The management/control protocol-neutral information model should be used as the base for defining management protocol-specific information models, for example XML (web service or Netconf/Yang) information model, common object request broker architecture (CORBA) interface definition language (IDL) model, and simple network management protocol (SNMP) management information base (MIB).

The information model defined in this Recommendation is an augmentation to the generic code model specified in [ITU-T G.7711] for managing MPLS-TP transport resources. The core information model defined in [ITU-T G.7711] can be used as the base for the extension of MPLS-TP-specific information models.

The specific mapping of the management/control protocol-neutral model into management/control-protocol-specific model is the decision of the management/control-protocol-specific solution design. For example, an object class defined in this Recommendation may be mapped into multiple tables in a SNMP MIB. Protocol-specific solutions and their mapping from the protocol-neutral model may be described in other Recommendations and is out of the scope of this Recommendation.

This Recommendation applies to MPLS-TP transport network elements and those systems that manage/control such network elements. The management/control system could be an NMS, EMS, SDN controller or a hybrid of them. [ITU-T G.7701] defines the management-control-continuum (MCC) concept whereby management and control functions are considered to be a continuum. Those systems are thus referred to as a management-control system (MCS) in general in this Recommendation. Functional capabilities of MPLS-TP transport equipment are defined in [ITU-T G.8121], [ITU-T G.8121.1], [ITU-T G.8121.2] and requirements of the management of MPLS-TP transport equipment are provided in [ITU-T G.7710] and [ITU-T G.8151]. The information model specified in this Recommendation applies to the management/control interface, as shown in Figure 1-1, specifically for managing/controlling the MPLS-TP functional capabilities of the NE.

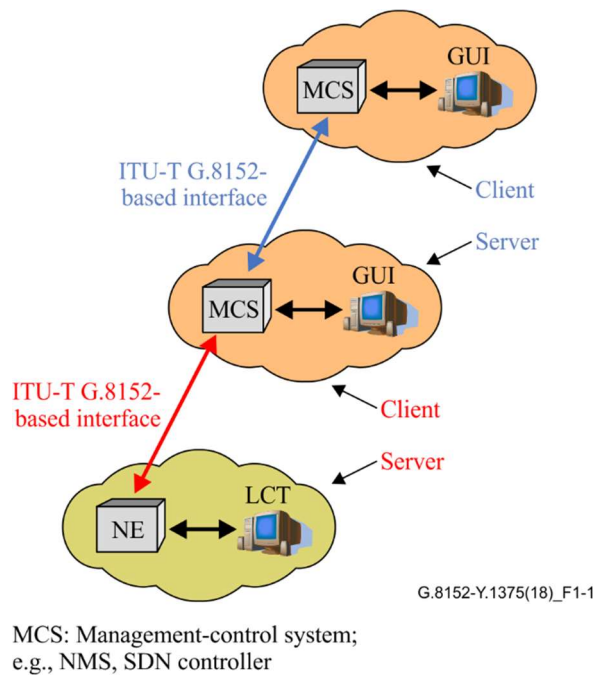

Figure 1-1 – Scope of ITU-T G.8152 interface

The object classes defined in this Recommendation cover the areas of fault management, configuration management, and performance management.

There are several different perspectives from which management information may be defined for management purposes. The network element viewpoint is concerned with the information that is required to manage a network element. This refers to information required to manage the network element function and the physical aspects of the network element. This Recommendation addresses only the network element view of Ethernet transport network management.

The management/control-protocol-neutral information model specified in this Recommendation consists of a set of transport-technology-specific managed object classes, i.e., MPLS-TP-specific managed object classes. These MPLS-TP-specific managed object classes are inherited from the generic managed object classes defined in other ITU-T Recommendation such as [ITU-T G.7711] and [ITU-T M.3160], including managed element, termination point and its subclasses, subnetwork, and subnetwork connection. Because of object class inheritance, the MPLS-TP management information model also inherits the generic object management capabilities, such as object creation/deletion, notification of object creation/deletion, attribute value retrieval/modification, notification of attribute/state value change, scoped and filtered retrieval of object instances, and abortion of outstanding operations. The description of these generic object management capabilities is provided in other ITU-T Recommendations, such as the ITU-T M.3700 series, and therefore is outside the scope of this Recommendation.

The object classes defined in this Recommendation cover the areas of fault management, configuration management, and performance management.

This Recommendation provides a representation of the MPLS-TP technology using the methodologies that have been used for other transport technologies (e.g., SDH, OTN and Ethernet).

2 References

The following ITU-T Recommendations and other references contain provisions which, through reference in this text, constitute provisions of this Recommendation. At the time of publication, the editions indicated were valid. All Recommendations and other references are subject to revision; users of this Recommendation are therefore encouraged to investigate the possibility of applying the most recent edition of the Recommendations and other references listed below. A list of the currently valid ITU-T Recommendations is regularly published. The reference to a document within this Recommendation does not give it, as a stand-alone document, the status of a Recommendation.

- [ITU-T G.7701] Recommendation ITU-T G.7701 (04/2022), *Common control aspects*.
- [ITU-T G.7710] Recommendation ITU-T G.7710/Y.1701 (10/2022), *Common equipment management function requirements*.
- [ITU-T G.7711] Recommendation ITU-T G.7711/Y.1702 (02/2022), *Generic protocol-neutral information model for transport resources*.
- [ITU-T G.8013] Recommendation ITU-T G.8013/Y.1731 (06/2023), *Operations, administration and maintenance (OAM) functions and mechanisms for Ethernet-based networks*
- [ITU-T G.8052] Recommendation ITU-T G.8052/Y.1346 (xx/2024), *Protocol-neutral management information model for the Ethernet transport capable network element*.
- [ITU-T G.8110.1] Recommendation ITU-T G.8110.1/Y.1370.1 (12/2011), *Architecture of the Multi-Protocol Label Switching transport profile layer network*.
- [ITU-T G.8113.1] Recommendation ITU-T G.8113.1/Y.1372.1 (11/2016), *Operations, administration and maintenance mechanism for MPLS-TP in packet transport network*.
- [ITU-T G.8113.2] Recommendation ITU-T G.8113.2/Y.1372.2 (08/2017), *Operations, administration and maintenance mechanisms for MPLS-TP networks using the tools defined for MPLS*.
- [ITU-T G.8121] Recommendation ITU-T G.8121/Y.1381 (11/2018), *Characteristics of MPLS-TP equipment functional blocks*.
- [ITU-T G.8121.1] Recommendation ITU-T G.8121.1/Y.1381.1 (11/2018), *Characteristics of MPLS-TP equipment functional blocks supporting ITU-T G.8113.1/Y.1373.1 OAM mechanisms*.
- [ITU-T G.8121.2] Recommendation ITU-T G.8121.2/Y.1381.2 (11/2018), *Characteristics of MPLS-TP equipment functional blocks supporting ITU-T G.8113.2/Y.1373.2 OAM mechanisms*.
- [ITU-T G.8131] Recommendation ITU-T G.8131/Y.1382 (07/2014), *Linear protection switching for MPLS transport profile, plus Amendment 1 (2016)*.
- [ITU-T G.8151] Recommendation ITU-T G.8151/Y.1374 (07/2023), *Management aspects of the MPLS-TP network element*.
- [ITU-T M.3010] Recommendation ITU-T M.3010 (2000), *Principles for a telecommunications management network*.
- [ITU-T M.3160] Recommendation ITU-T M.3160 (2008), *Generic protocol-neutral management information model*.
- [ITU-T Q.822] Recommendation ITU-T Q.822 (1994), *Stage 1, stage 2 and stage 3 description for the Q3 interface – Performance management*.

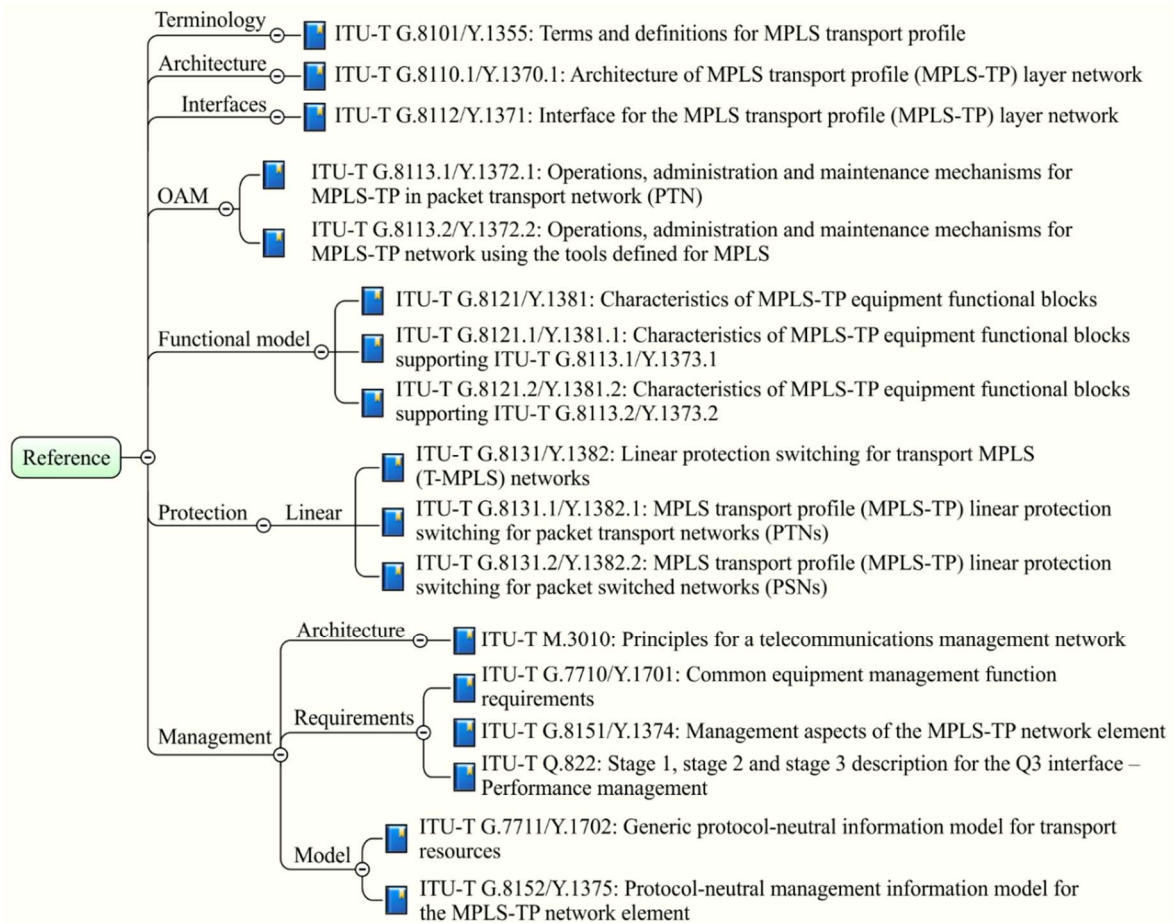

G.8152-Y.1375(16)_F2-1

Figure 2-1 – Structure of references

3 Definitions

3.1 Terms defined elsewhere

This Recommendation uses the following terms defined elsewhere:

- 3.1.1 **atomic function** [ITU-T G.806]
- 3.1.2 **compound function** [ITU-T G.806]
- 3.1.3 **dual-ended**: [ITU-T G.8013]
- 3.1.4 **maintenance entity (ME)**: [ITU-T G.8013]
- 3.1.5 **maintenance entity group (MEG)**: [ITU-T G.8013]
- 3.1.6 **MEG end point (MEP)** [ITU-T G.8013]
- 3.1.7 **MEG intermediate point (MIP)** [ITU-T G.8013]
- 3.1.8 **on-demand monitoring**: [ITU-T G.8052]
- 3.1.9 **one-way**: [ITU-T G.8013]
- 3.1.10 **proactive monitoring**: [ITU-T G.8052]
- 3.1.11 **single-ended**: [ITU-T G.8013]
- 3.1.12 **two-way**: [ITU-T G.8013]

3.2 Terms defined in this Recommendation

None.

4 Abbreviations and acronyms

This Recommendation uses the following abbreviations and acronyms:

1DM	One-way Delay Measurement
1DMo	On-demand one-way Delay Measurement
1DMp	Proactive one-way Delay Measurement
AIS	Alarm Indication Signal
APS	Automatic Protection Switching
CCM	Continuity Check Message
CD	Current Data
CORBA	Common Object Request Broker Architecture
CTP	Connection Termination Point
CW	Control Word
DEG	Degraded
DM	Delay Measurement
DMo	On-demand Delay Measurement
DMp	Proactive Delay Measurement
DP	Data Plane
ECC	Embedded Communication Channel
EMS	Element Management System
ETH	Ethernet MAC layer network
G-ACh	Generic Associated Channel
GAL	Generic Associated Channel (G-ACh) Label
GFP	Generic Framing Procedure
HD	History Data
IDL	Interface Definition Language
LCK	Locked
LM	Loss Measurement
LMo	On-demand Loss Measurement
LMp	Proactive Loss Measurement
LMR	Loss Measurement Reply
LOC	Loss of Continuity
LSP	Label Switched Path
LT	Link Trace
MAC	Medium Access Control

MCC	Management Communication Channel
ME	Maintenance Entity
MEG	Maintenance Entity Group
MEP	Maintenance entity group End Point
MI	Management Information
MIB	Management Information Base
MIP	Maintenance entity group Intermediate Point
MPLS	Multi-Protocol Label Switching
MPLS-TP	Multi-Protocol Label Switching – Transport Profile
MT	Multi-Protocol Label Switching – Transport Profile
MTD	MPLS-TP Diagnostic function
MTDi	MPLS-TP Diagnostic function within MTx MIP
MTS	MPLS-TP Section
NC	Network Connection
NCM	Network Connection Monitoring
NE	Network Element
OAM	Operation, Administration and Maintenance
PHB	Per Hop Behaviour
PM	Performance Monitoring
PRI	Priority
PSC	PHB Scheduling Class
QoS	Quality of Service
RDI	Remote Defect Indication
SCC	Signalling Communication Channel
SCC Type	Signalling Communication Channel Type
SES	Severely Errored Second
Sk	Sink
SLA	Service Level Agreement
SL	Synthetic Loss Measurement
SLp	Proactive Synthetic Loss Measurement
SLo	On-demand Synthetic Loss Measurement
SN	Sub-Network
SNC	Sub-Network Connection
SNCP	Sub-Network Connection Protection
SNMP	Simple Network Management Protocol
So	Source
SQ	Sequence

TC	Traffic Class
TCM	Tandem Connection Monitoring
TCS	Traffic Conditioning and Shaping
TH	Throughput
TMN	Telecommunications Management Network
TP	Termination Point
TSNUM	Tributary Slot Number
TT	Trail Termination
TTL	Time-To-Live
TTP	Trail Termination Point
UAS	Unavailable Second
UML	Unified Modelling Language

5 Conventions

5.1 Information modelling conventions

See clause 5.1 of [ITU-T G.7711].

5.1.1 UML modelling conventions

See clause 5.1 of [ITU-T G.7711].

5.1.2 Model Artefact Lifecycle Stereotypes conventions

See clause 5.2 of [ITU-T G.7711].

5.1.3 Forwarding entity terminology conventions

See clause 5.3 of [ITU-T G.7711].

5.1.4 Conditional package conventions

See clause 5.4 of [ITU-T G.7711].

5.1.5 Pictorial diagram conventions

See clause 5.5 of [ITU-T G.7711].

5.2 Equipment function conventions

5.2.1 Maintenance entity group end point (MEP) [ITU-T G.8121]

MEG end points (MEPs) terminate maintenance entities (MEs) which can span the end-to-end network connection or a portion of the network connection defined as a tandem connection.

The diagrammatic convention for network connection monitoring MEP (NCM MEP) compound functions is shown in Figure 5-1:

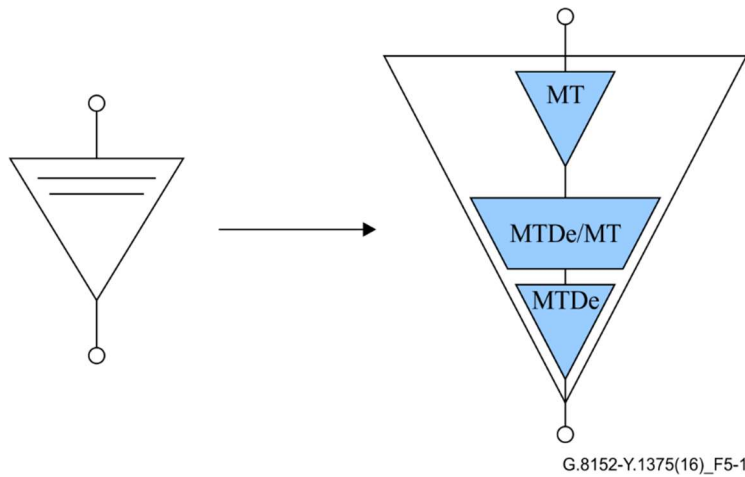

**Figure 5-1 – MT NCM MEP compound functions
(Same as Figure 9-39 of [ITU-T G.8121])**

The diagrammatic convention for tandem connection monitoring MEP (TCM MEP) compound functions is shown in Figure 5-2.

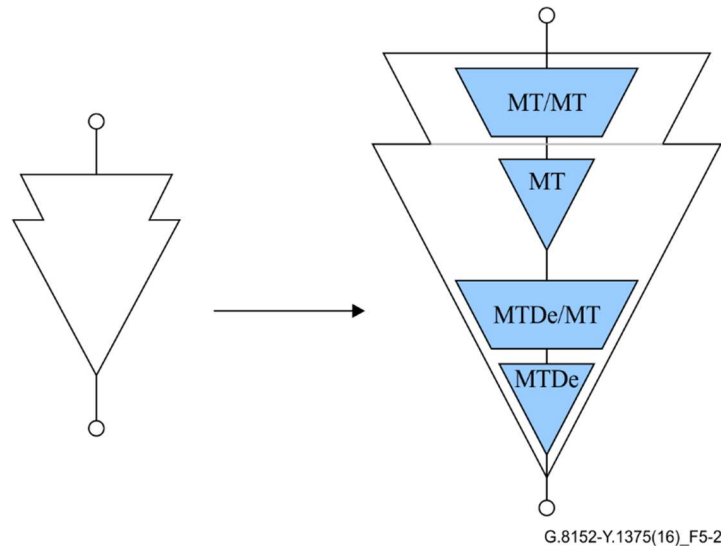
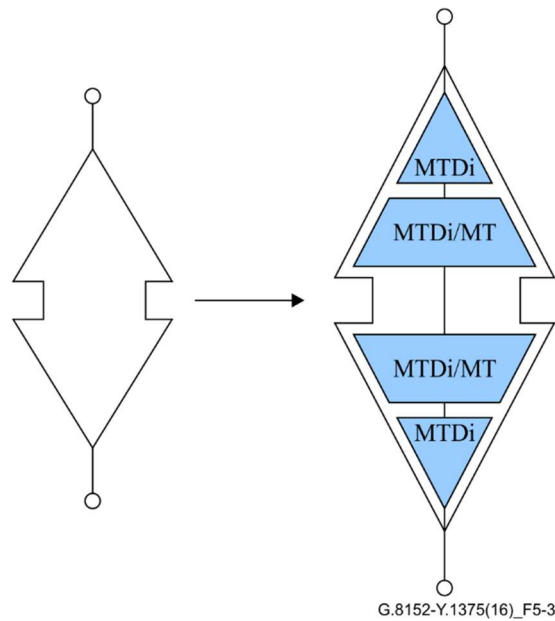

**Figure 5-2 – MT TCM MEP compound functions
(Same as Figure 9-40 of [ITU-T G.8121])**

NOTE – Unlike the Ethernet technology, the same MT/MT atomic function defined in [ITU-T G.8121] can be used either within the optional TCM MEP (i.e., not "stand alone") or at the layer boundary (i.e., "stand alone" and not be a part of a MEP), regardless of the number of client signals (even in case of only one signal when there is no multiplexing).

5.2.2 Maintenance entity group intermediate point (MIP) [ITU-T G.8121]

The diagrammatic convention for MIP compound functions is shown in Figure 5-3.



**Figure 5-3 – MT MIP compound functions
(Same as Figure 9-41 of [ITU-T G.8121])**

The diagrammatic convention for half MIP compound functions is shown in Figure 5-4.

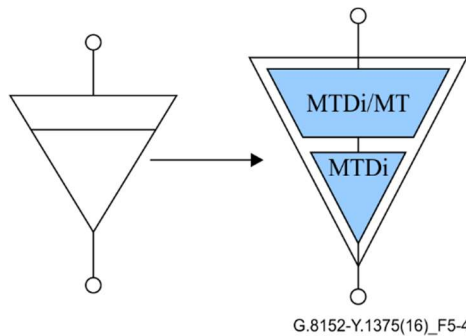

**Figure 5-4 – MT half MIP compound functions
(Same as Figure 9-42 of [ITU-T G.8121])**

5.2.3 MEPs and MIPs along a Maintenance Entity

The diagrammatic convention for MEPs and MIPs along an individual ME as shown in Figure 5-5:

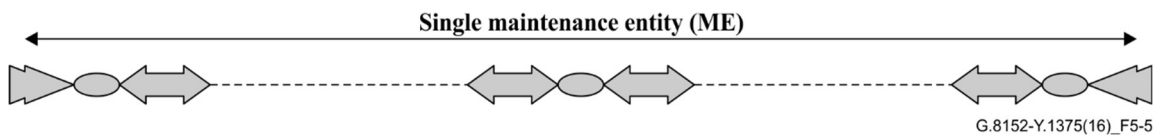

Figure 5-5 – MEPs and MIPs along a maintenance entity (ME)

Note that the ME can span the whole end-to-end network connection or a portion of it called a tandem connection.

5.3 Conventions defined in this Recommendation

This Recommendation uses the following conventions:

5.3.1 Colour code convention

The following "colour code" is used in this Recommendation:

Table 5-1 – Colour code convention

"colour code"	ITU-T G.8152 object class
	MaintenanceEntityGroupEndPoint
	MT_TrailTerminationPoint
	MT_ConnectionTerminationPoint
	OnDemandMeasurementJob
	ProActiveMeasurementJob
	MaintenanceJob
	TerminationPointPool
	Specific highlighting
	Not in scope

5.3.2 Modelling convention for adaptation functions

Every adaptation function has a MI_Active parameter. This is not modelled since it will always be active in the MPLS-TP technology.

5.3.2.1 MPLS-TP server adaptation modelling

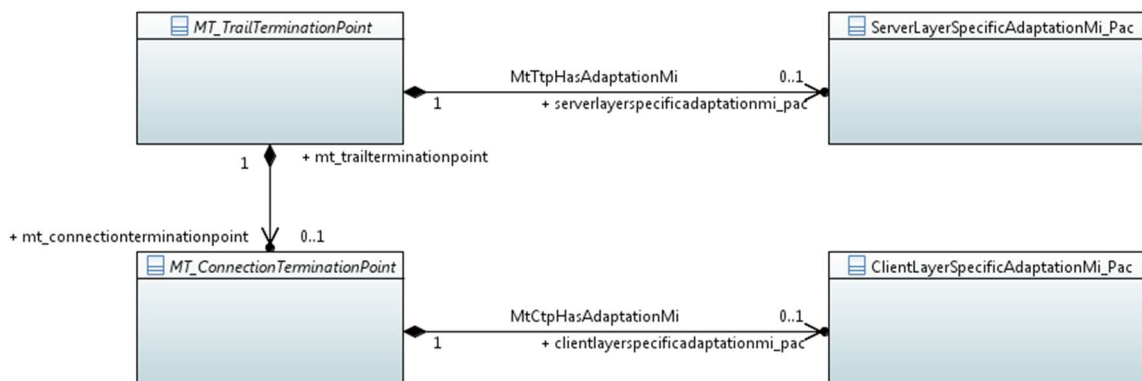
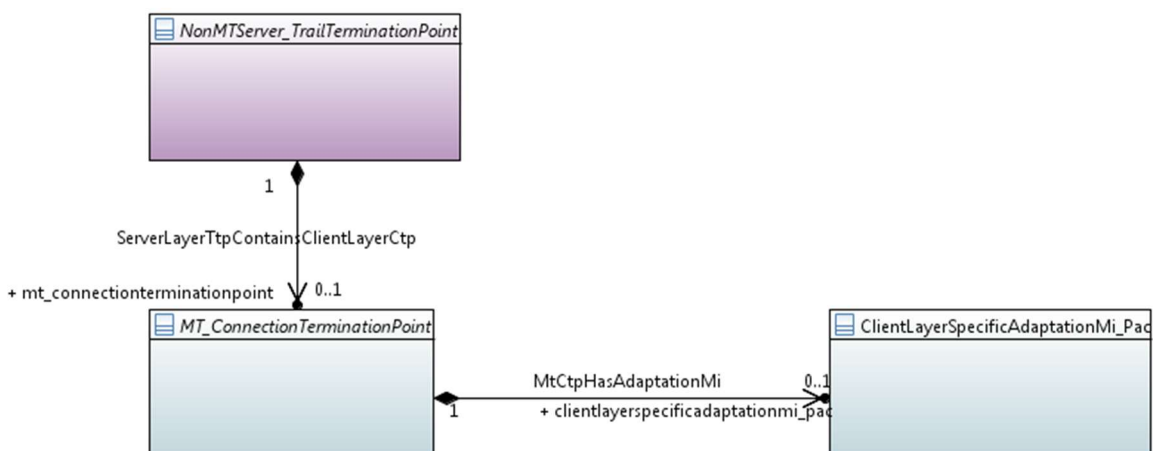

Figure 5-6 – Illustrative diagram for MPLS-TP server adaptation modelling

5.3.2.2 Non-MPLS-TP server adaptation modelling



NOTE – This figure is also available from the ITU website [here](#).

Figure 5-7 – Illustrative diagram for non-MPLS-TP server adaptation modelling

6 Overview of the MPLS-TP model

This Recommendation models the MPLS-TP network functions that are relevant to MPLS-TP network elements management. These functions are defined in the equipment specification [ITU-T G.8121], [ITU-T G.8121.1] and [ITU-T G.8121.2] for the termination, adaptation, and connection functions of the Multi-Protocol Label Switching – Transport Profile (MT) layer, OAM functions at the maintenance entity group (MEG) end point (MEP) and intermediate point (MIP), diagnostic maintenance operations, performance measurement (including on-demand and proactive), MPLS-TP linear protection (ELP), and MPLS-TP ring protection (ERP). In particular, the input and output management information (MI) exchanged across the management point (MP) between the equipment transport functions (TF) and equipment management function (EMF) are modelled. The input/output MIs cover the areas of configuration, fault management, and performance management as described in [ITU T G.7710] and [ITU T G.8151]. Details of the management functions that need to be modelled are provided in [ITU-T G.7710] and [ITU T G.8151].

In this Recommendation, managed resources and management support resources are modelled as objects in the information model. The management view of a resource is a managed object. This Recommendation specifies the properties of the resources visible for management. Objects with similar properties are grouped into object classes. An object instance is an instantiation of an object class. The properties of an object include the behaviour, attributes and operations that can be applied to the object. An object instance is characterized by its object class and may possess multiple attribute types and associated values. In the protocol-neutral model, object classes are represented as unified modelling language (UML) object classes – for static properties, interface classes – for operations, and signal classes – for notifications.

Object classes, attribute types, operations and notifications are defined for the purpose of communicating network management messages between managed systems (such as the transport devices) and the management-control (MC) systems (MCS). They need not be related to the structure of data stored within those systems.

An object class may be a subclass of another class. A subclass inherits properties of its superclass, in addition to possessing its own specific attributes and properties. In this Recommendation, the MPLS-TP specific transport object classes are defined. Some of these object classes are derived from the [ITU-T G.7711] core information model through pruning and/or refactoring.

In addition to the MPLS-TP transport resource, the model also includes object classes for management support functions such as alarm reporting control and alarm severity assignment.

6.1 MT layer

Figure 6-1 below shows the mapping between the object classes and the MPLS-TP atomic functions based on Figure 1 of [ITU-T G.8121].

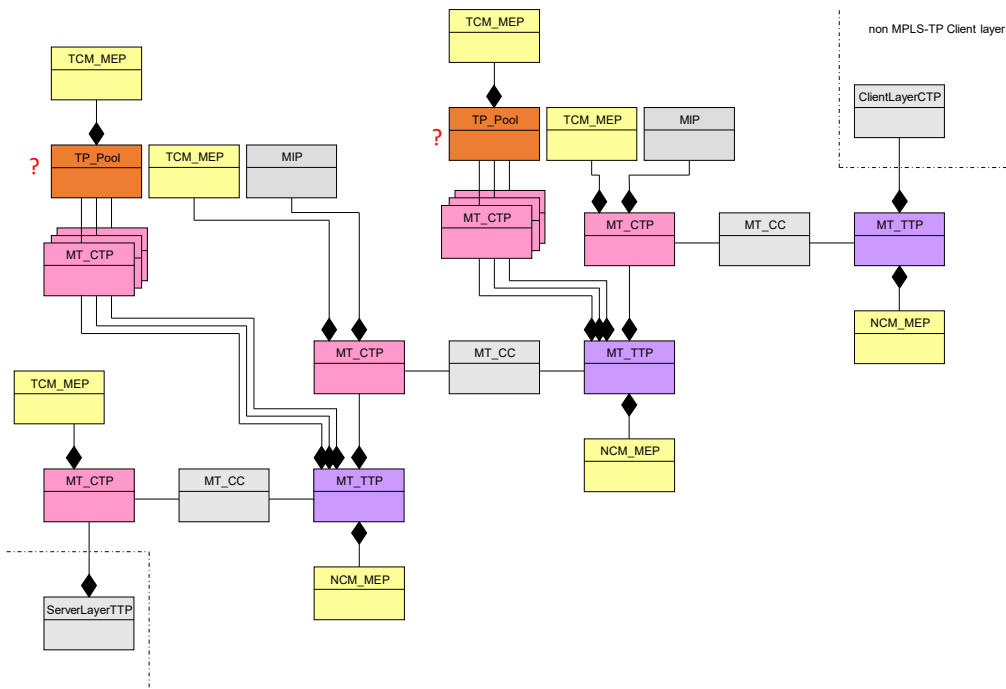

Figure 6-2 – MT object instance example

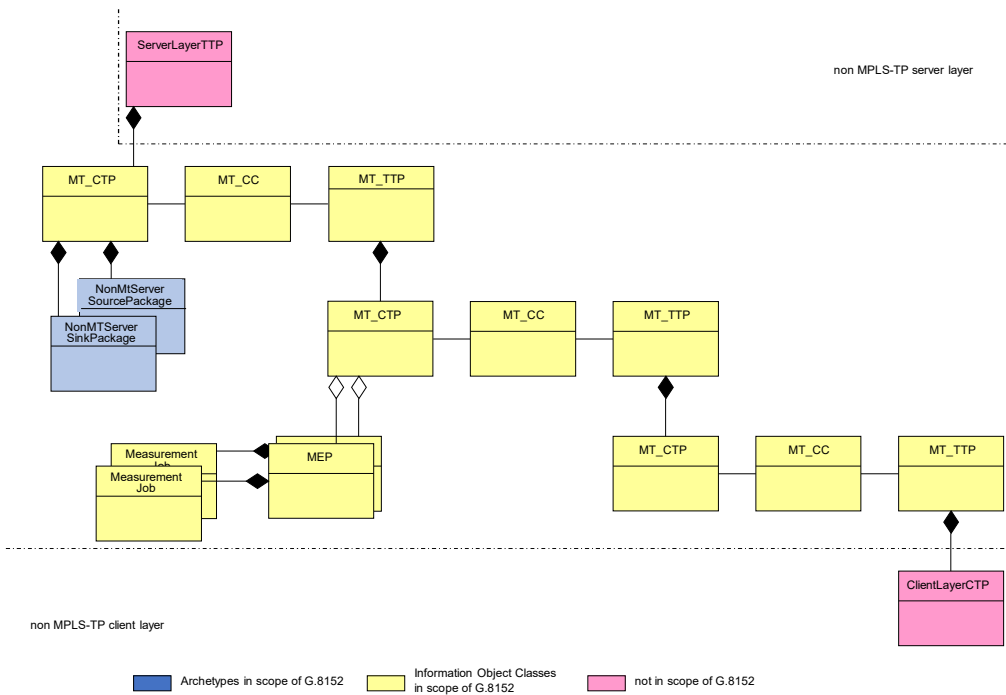

Figure 6-3 – MT layer object instance example with measurement job

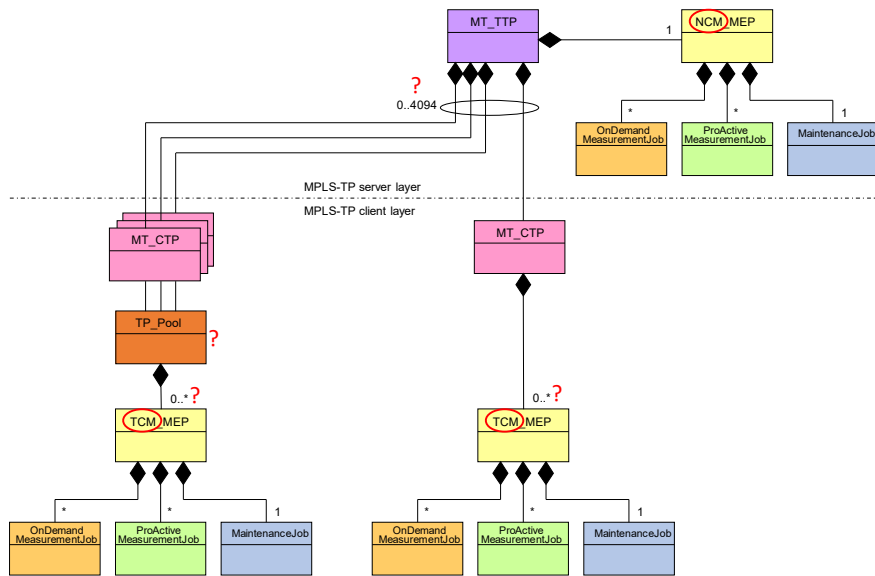

Figure 6-4 – MEP infrastructure with maintenance and measurement jobs

7 UML Model of MPLS-TP

7.1 MT fragment

7.1.1 MT CTP object classes

The MtCtp (MPLS-TP Connection Termination Point) object class is defined via pruning and refactoring of the G.7711 LTP (Logical Termination Point) and LP (Layer Protocol) object classes, when the LTP has a server LTP and it includes only one LP with layerProtocolName = 'MT' and terminationState = 'LP_CAN_NEVER_TERMINATE'.

The MtCtp object class is «ExtendedComposite»¹ with the MPLS-TP technology-specific attributes defined within the MtCtpPac, MtCtpSourcePac, MtCtpSinkPac and MtCtpBidirPac abstract object classes as shown in Figure 7-1.A.

¹ The «ExtendedComposite» aggregation means that the extending class will never be explicitly instantiated (i.e., are abstract), but that the attributes defined by the extending class will be transferred to the class being extended at runtime.

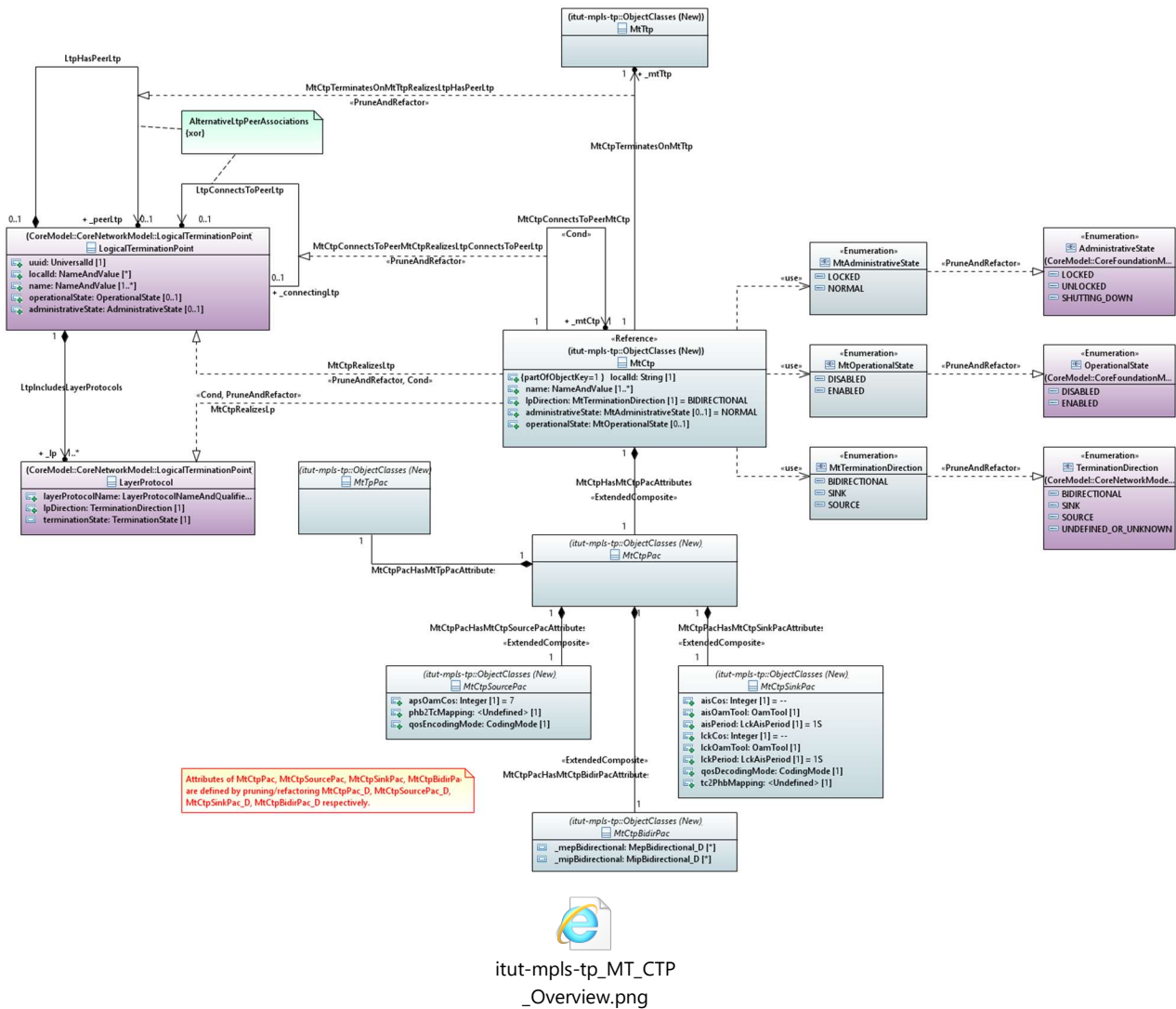
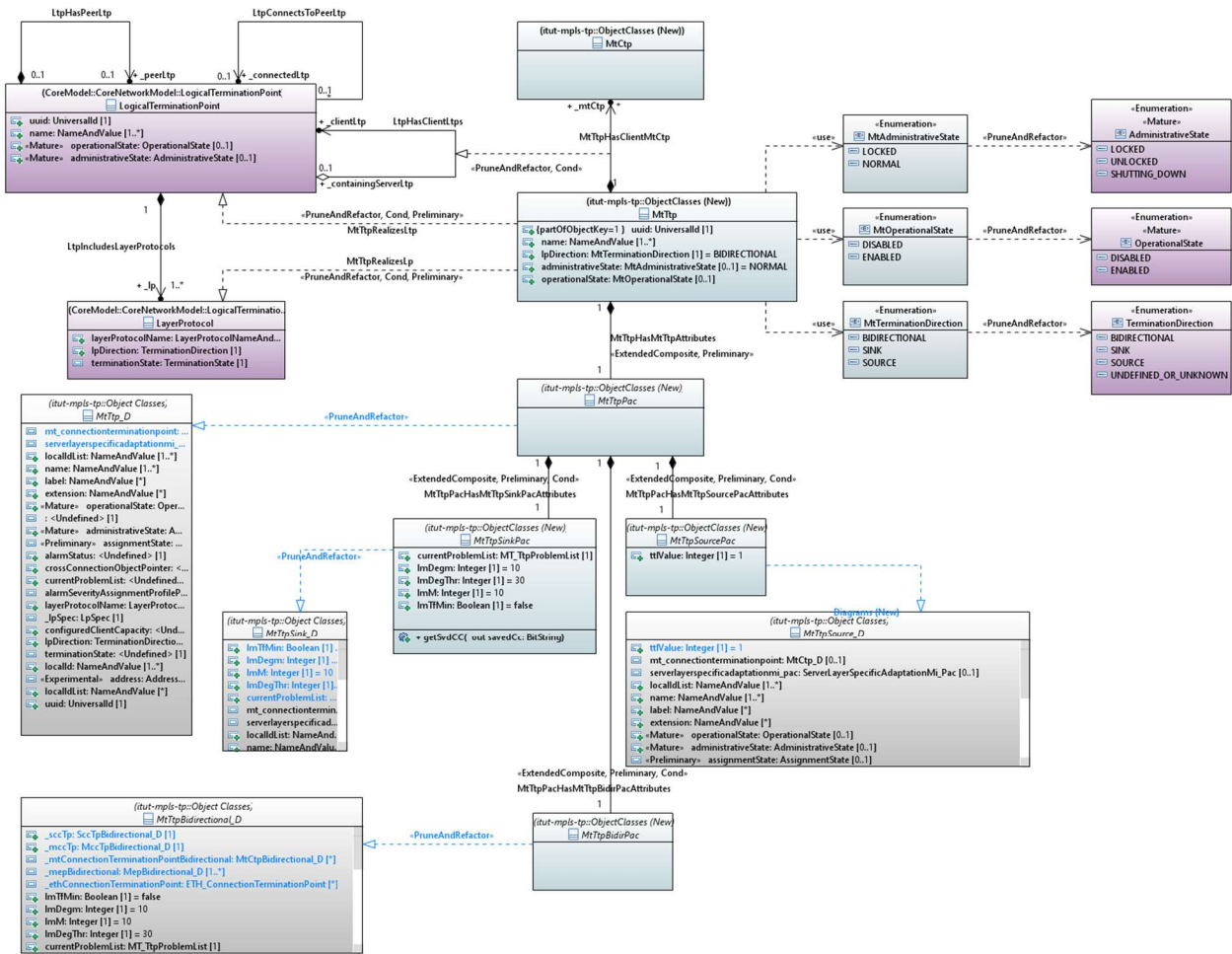

Figure 7-1.A – MPLS-TP CTP Overview

7.1.2 MT TTP object classes

The MtTtp (MPLS-TP Trail Termination Point) object class is defined via pruning and refactoring of the G.7711 LTP (Logical Termination Point) and LP (Layer Protocol) object classes, when LTP has no server layer LTP and it contains only one LP with layerProtocolName = 'MT' and terminationState = 'LP_PERMENANTLY_TERMINATED'.

The MtTtp object class is «ExtendedComposite» with the MPLS-TP technology-specific attributes defined within the *MtTtpPac*, *MtTtpSourcePac*, *MtTtpSinkPac* and *MtTtpBidirPac* abstract object classes as shown in Figure 7-1.B.



itut-mpls-tp_MT_TTP_Overview.png

Figure 7-1.B – MPLS-TP TTP Overview

7.1.3 MT connectivity object classes

In order to model flexible MT Connectivity, the MtSn, MtSnc and MtSncPort object classes are defined via pruning and refactoring of the [ITU-T G.7711] core model FD, FC and FcPort object classes, as shown in Figure 7-1.C below:

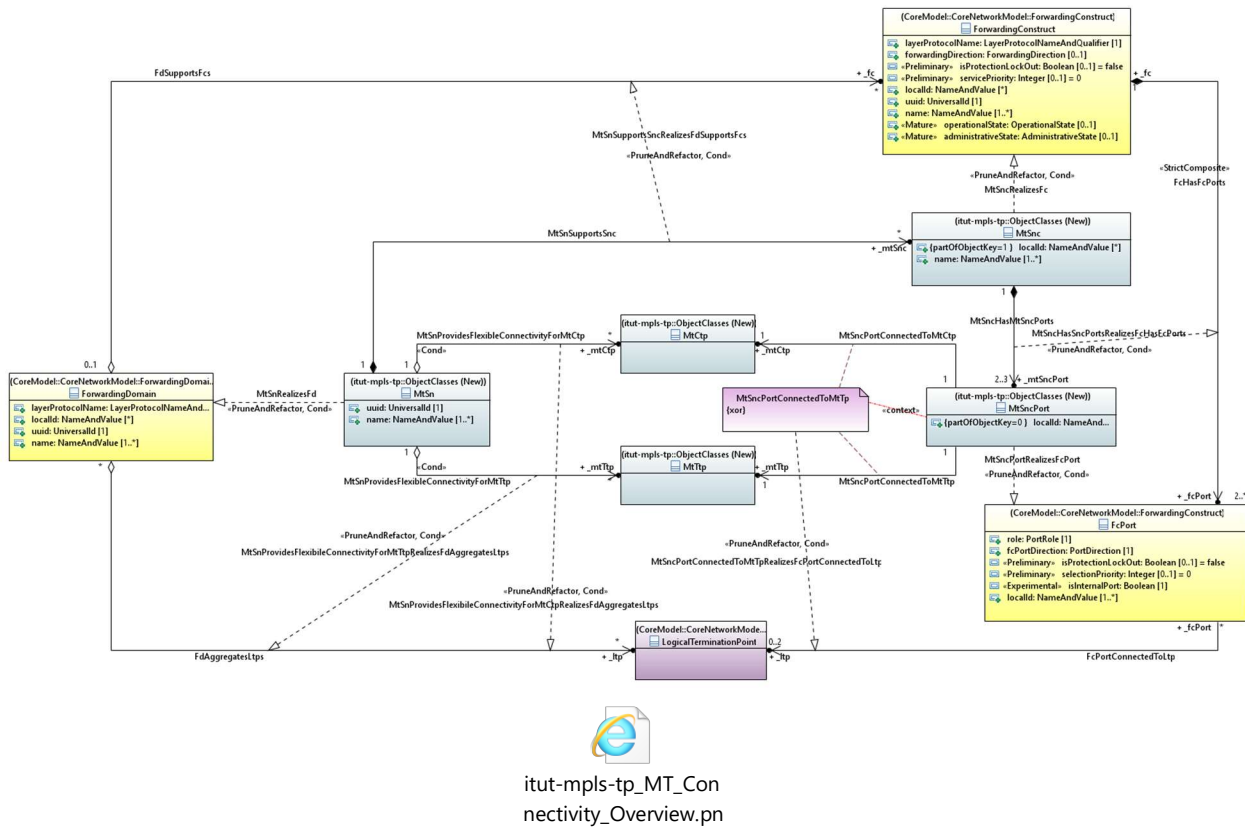

Figure 7-1.C – MPLS-TP connectivity Overview

In particular:

- The MtSn object class is defined via pruning and refactoring of the [ITU-T G.7711] FD object class when it has only one layerProtocolName = 'MT'.
- The MtSnc object class is defined via pruning and refactoring of the [ITU-T G.7711] FC object class when layerProtocolName = 'MT'.
 - The MtSnc object class has been refactored from the [ITU-T G.7711] FC global object class as a local object class, as defined in [ITU-T G.7711], and the MtSnSupportsSnc has been refactored as a composition, since for the purpose of NE management the FC object class instances always exist within an FD object class instance.
- The MtSncPort object class is defined via pruning and refactoring of the [ITU-T G.7711] FcPort object class when the FC instance is realized by an MtSnc instance.

As a consequence:

- The MtSnSupportsSnc and the MtSncHasSncPorts associations have been defined via pruning and refactoring of, respectively, the [ITU-T G.7711] FdSupportsFcs and FcHasFcPorts associations.
- The relationship between the MtSncPort and the MtCtp or MtTtp being connected is modelled by the MtSncPortConnectedToMtTp {xor} constraint between the MtSncPortConnectedToMtCtp and MtSncPortConnectedToMtTtp associations, defined via pruning and refactoring of the [ITU-T G.7711] FcPortConnectedToLtp association.

An MtCtp instance can have either:

- Flexible connectivity via an MtSn instance (e.g., as shown in Figure 7-1.C), which is modelled by the MtSnProvidesFlexibleConnectivityForMtCtp association, defined via pruning and refactoring of the [ITU-T G.7711] FdAggregatesLtp association.

- Fixed connectivity with a peer MtCtp instance (e.g., as shown in Figure 7-1.A), which is modelled by the MtCtpConnectsToPeerMtCtp association, defined via pruning and refactoring of the [ITU-T G.7711] LtpConnectsToPeerLtp association.
- Fixed termination on an MtTtp instance (e.g., as shown in Figure 7-1.A), which is modelled by the MtCtpTerminatesOnMtTtp association, defined via pruning and refactoring of the [ITU-T G.7711] LtpHasPeerLtp association.

An MtTtp instance can have either:

- Flexible connectivity via an MtSn instance (e.g., as shown in Figure 7-1.C), which is modelled by the MtSnProvidesFlexibleConnectivityForMtTtp association, defined via pruning and refactoring of the [ITU-T G.7711] FdAggregatesLtp association.
- Fixed termination for an MtCtp instance (as shown Figure 7-1.A), which is modelled by the MtCtpTerminatesOnMtTtp association, defined via pruning and refactoring of the [ITU-T G.7711] LtpHasPeerLtp association

7.1.4 MT Multiplexing

This clause maps the MPLS-TP multiplexing related MIs to the corresponding object classes.

The MPLS-TP multiplexing configuration function exists only in MT TTP and MT CTP.

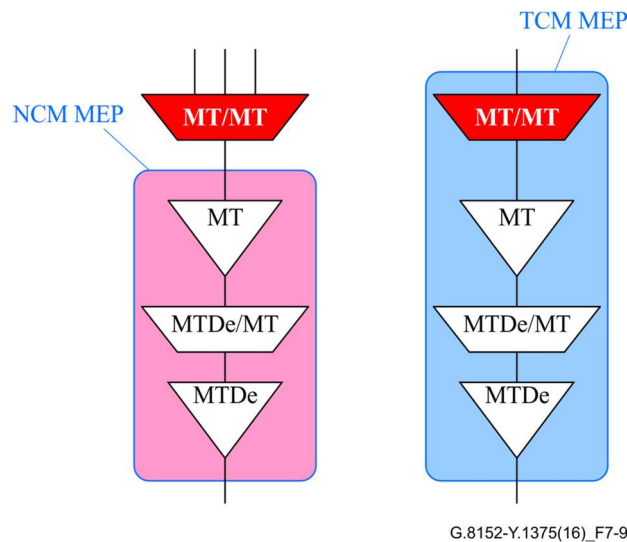

Figure 7-1.D – MPLS-TP multiplexing configuration function

[ITU-T G.8121] defines the following management information (MI) for configuring the MPLS-TP multiplexing function, as given in Table 7-1.

Table 7-1 – Mapping of multiplexing related MI to ITU-T G.8152 artefacts

Functionality	ITU-T G.8121 MT/MT_A_So_MI	ITU-T G.8121 MT/MT_A_Sk_MI	ITU-T G.8152 v4.0 object class
TTP associated M	Admin_State	Admin_State	MtTtp
	Mode	Mode	MtMuxServerTtp Pac
	APS_CoS		MtMuxServerTtp SourcePac

Functionality	ITU-T G.8121 MT/MT_A_So_MI	ITU-T G.8121 MT/MT_A_Sk_MI	ITU-T G.8152 v4.0 object class
	APS_OAM_Tool	APS_OAM_Tool	MtMuxServerTtp Pac
CTP associated MI	Label[1...M]	Label[1...M]	MtMuxClientCtp Pac
	LSPTType[1...M]	LSPTType[1...M]	MtMuxClientCtp Pac
	CoS[1...M]	CoS[1...M]	MtMuxClientCtp Pac
	PHB2TCMapping[1...M]	TC2PHBMapping[1...M]	MtMuxClientCtp [Source Sink]Pac
	QoSEncodingMode[1...M]	QoSDecodingMode[1...M]	MtMuxClientCtp [Source Sink]Pac
	LCK_Period[1...M]	LCK_Period[1...M]	MtMuxClientCtp Pac
	LCK_CoS[1...M]	LCK_CoS[1...M]	MtMuxClientCtp Pac
	LCK_OAM_Tool[1...M]	LCK_OAM_Tool[1...M]	MtMuxClientCtp Pac
	GAL_Enable[1...M]	GAL_Enable[1...M]	MtMuxClientCtp Pac
		AIS_Period[1...M]	MtMuxClientCtp SinkPac
		AIS_CoS[1...M]	MtMuxClientCtp SinkPac
		AIS_OAM_Tool[1...M]	MtMuxClientCtp SinkPac

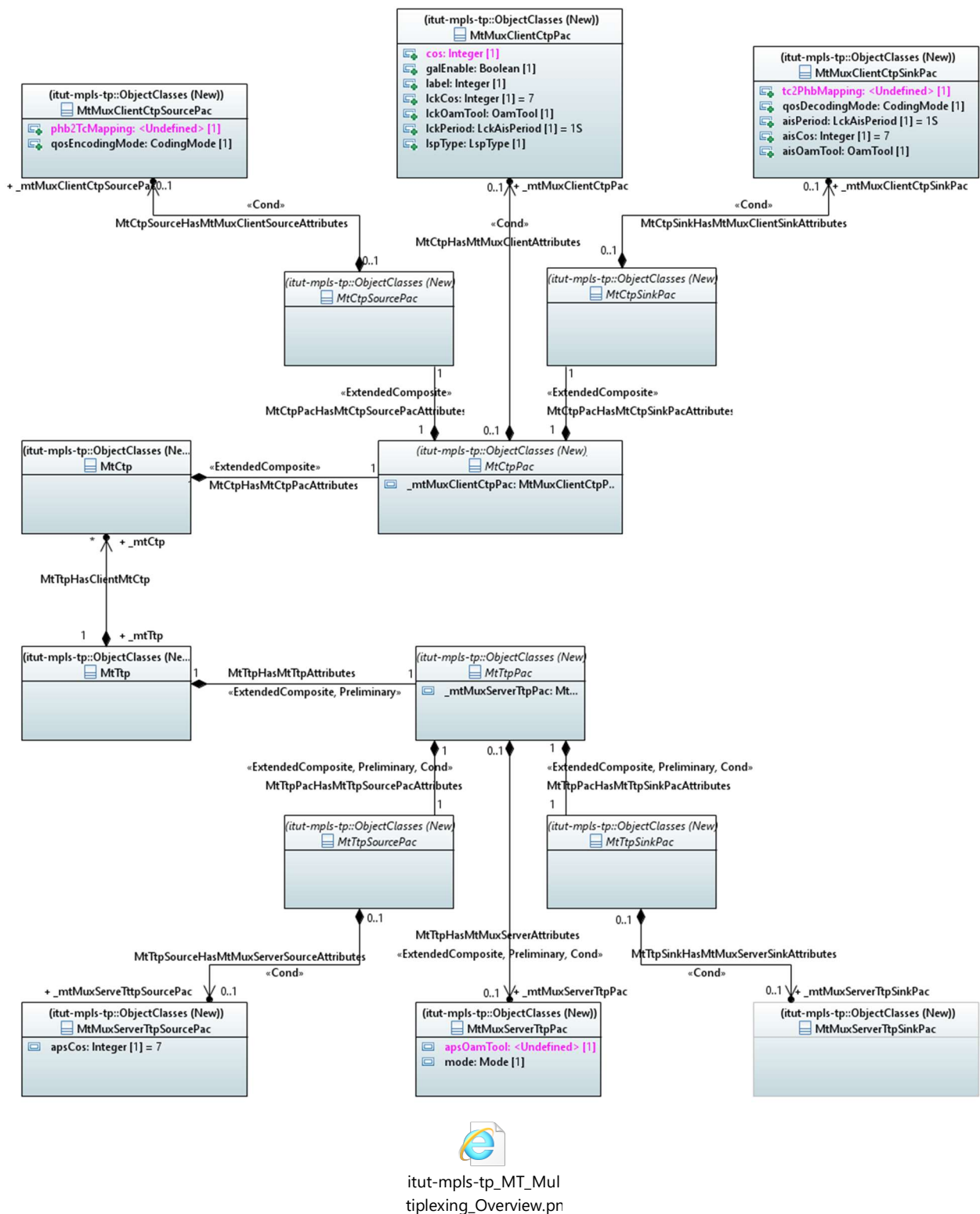

Figure 7-1.E – MPLS-TP multiplexing model overview

7.1.5 MPLS-TP CTP and TTP auxiliary object classes

The MtAuxTp object class is defined via pruning and refactoring of the LP object class, when the layerProtocolName is set to 'MT_MEP' or 'MT_MIP', as shown in Figure 7-1.H.

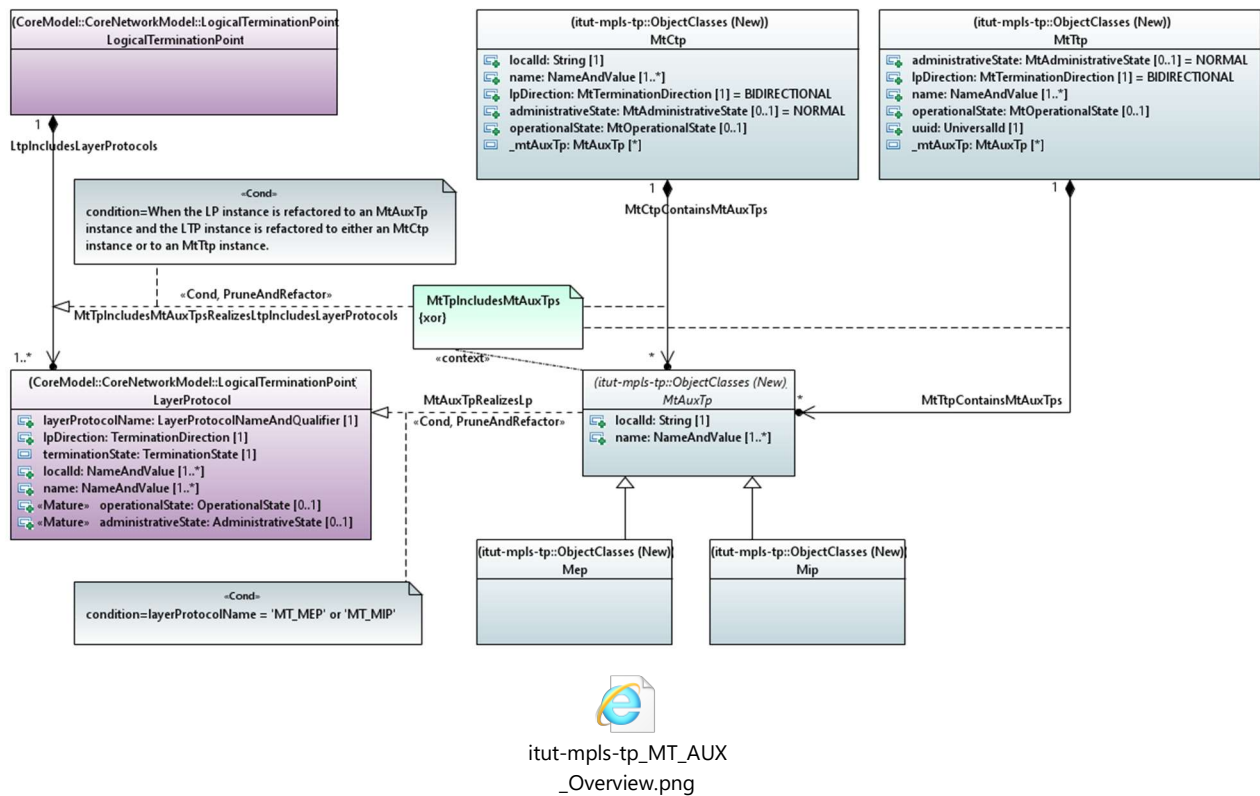

Figure 7-1.F – MPLS-TP auxiliary object classes

The *MtAuxTp* object class is an abstract object class that is inherited by the object classes, described in clauses 7.1.1, 7.1.2 and 7.2, used to model MPLS-TP (MT) auxiliary functions.

MT auxiliary functions can be located either:

- between the adaptation function and the connection function, as modelled by the *MtCtpContainsMtAuxTps* association; or,
- between the connection function and the trail termination function, as modelled by the *MtTipContainsMtAuxTps* association.

The *MtTipIncludesMtAuxTps* constraint is used to model the fact that a given *MtAuxTp* object class instance is either contained by an *MtCtp* or by an *MtTip* object class instance and in the latter case it is either located below the trail termination function or above the trail termination function.

The *MtCtpContainsMtAuxTps* and *MtTipContainsMtAuxTps* associations defined, together with the *MtTipIncludesMtAuxTps* constraint, via pruning and refactoring of the G.7711 *LpIncludesLayerProtocols* ordered association. The *MtCtpContainsMtAuxTps* and *MtTipContainsMtAuxTps* are ordered.

7.2 OAM fragment

See Annex A.1 for the general description of the MPLS-TP OAM compound functions.

7.2.1 MEP compound function

See Annex A.1.1 for the description of the MPLS-TP compound function.

Figure 7-2.A below provides an overview of the MT MEP model.

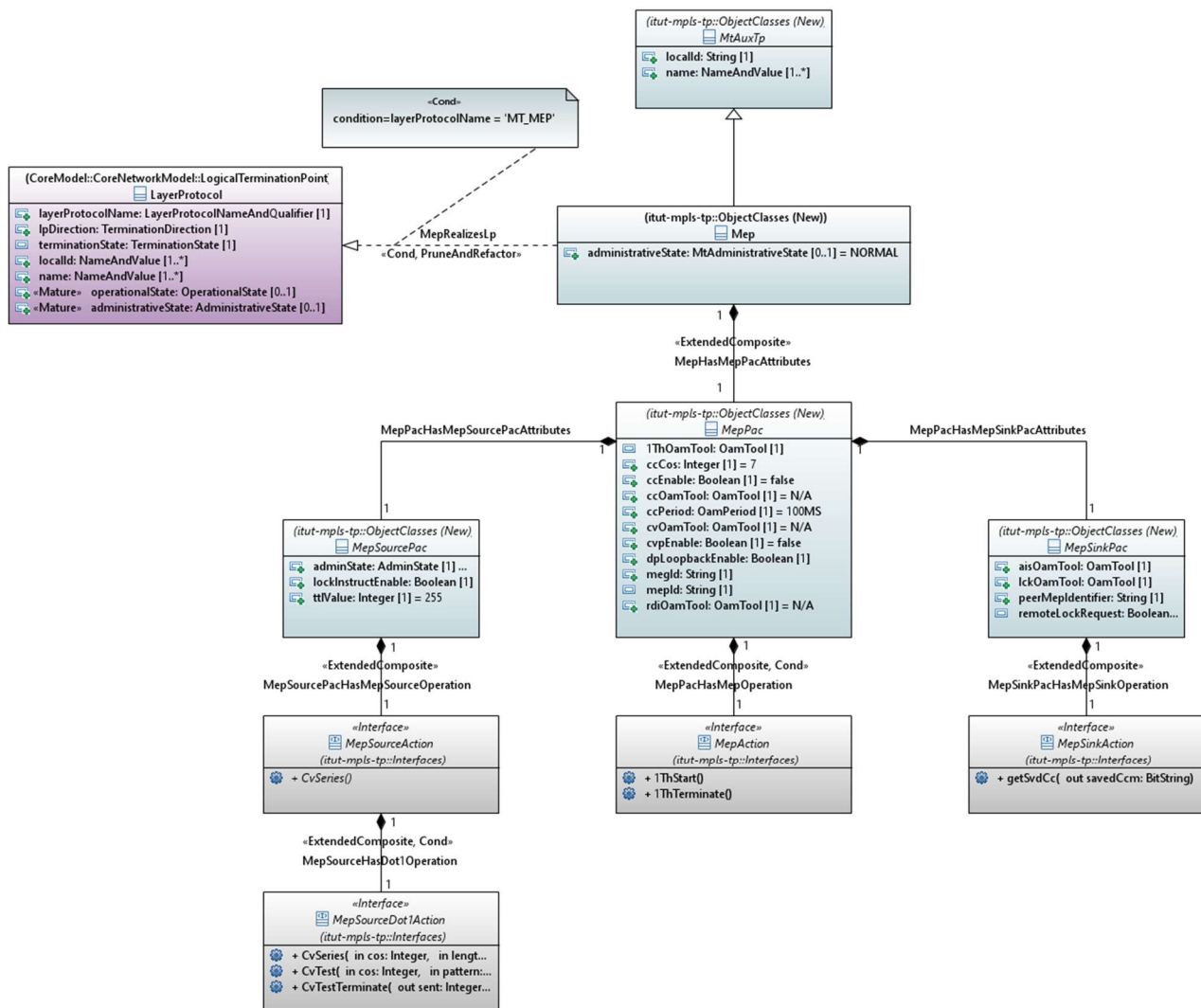

itut-mpls-tp_MT_ME
P_Overview.png

Figure 7-2.A – MT MEP Overview

7.2.2 MIP compound function

Figure 7-2.B below depicts the object classes of the MIP model. Details of the functions supported by the model are described in Annex A.1.2.

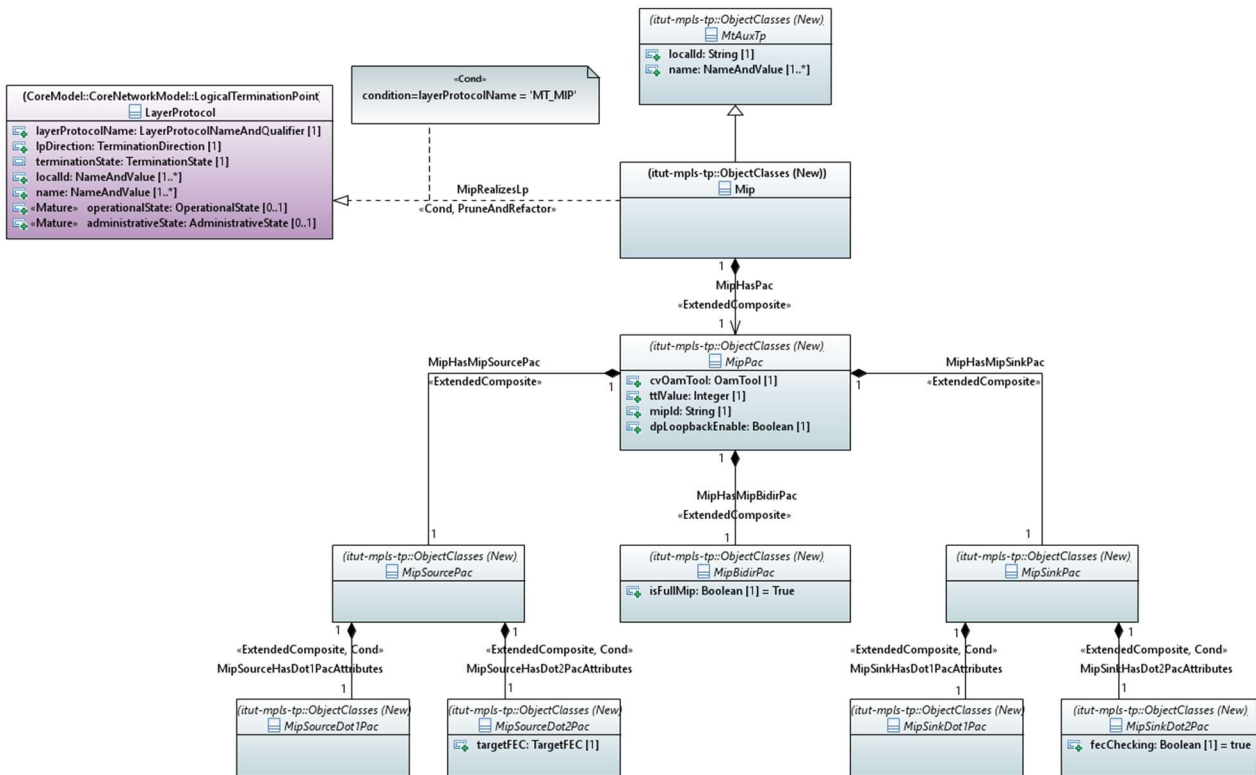

itut-mpls-tp_MT_MIP
_Overview.png

Figure 7-2.B– MT MIP Overview

8 UML model file

Embedded below is a zip file, which contains the G.8152 UML model developed using the Papyrus open-source modelling tool.



G.8152_v2.0.9_uml.zip

This zip file contains the following folders:

- The G.8152 folder, which contains the following files:
 - The papyrus project file
 - .project
 - The .di, .notation, and .uml files of the following modules
 - itut-mpls-tp (the v3.0 model)
 - G.8152_v2.00-model (the v2.0 model)
 - The gdITUTemplate-8152.docx file, which can be used to generate the data dictionary (DD) form of the G.8152 UML model

- The doc sub-folder, which contains the data dictionary of the G.8152 UML model
- The UmlProfiles sub-folder, which contains the UML Profiles that defines the properties of the UML artifacts.
 - The OpenModelProfile folder, which contains the .di, .notation, and uml of the open model profile
 - The OpenInterfaceModelProfile folder, which contains the .di, .notation, and uml of the open model interface profile
 - The ProfileLifecycleProfile folder, which contains the .di, .notation, and uml of the profile lifecycle profile
 - The ClassDiagramStyleSheet.css style sheet
- The diagrams sub-folder, which contains the PNG images of all the class diagrams.
- The G.7711 folder, which contains the [ITU-T G.7711] Core model that is needed (i.e., imported) by the G.8152 model.

NOTE-1: If the imported model has been up-versioned or has changed the module name, then the xmi code of the G.8152 module will need to be updated.

To load the G.8152 UML model into an Eclipse Papyrus workspace, follow the steps below:

- In the Project Explorer / right click / Import / General / Projects from Folder or Archive / Next / Archive / Select the G.8152 zip file / Open / Select the folders of the models to be loaded (NOTE) / Finish

NOTE-2: If a supporting (i.e., to be imported by G.8152) model already exists in the workspace, do not select it for loading.

NOTE-3: The ITU-T G.8152/Y.1375 UML information model and the Open Model Profile are specified using the Papyrus open source modeling tool. In order to view and further extend or modify the information model, one will need to install the open source Eclipse software and the Papyrus tool, which are available at [b-Eclipse-Papyrus]. The installation guide for Eclipse and Papyrus can be found in [b-ONF TR-515].

NOTE 4 – The ITU-T G.8152 UML information models expressed in a data dictionary form has been produced for the convenience of readers who do not have access to the Papyrus tool. The data dictionary presents the model artifacts in tabular format. The G.8152 data dictionary is embedded below.



G.8152_v2.0.9_DD.zip

Annex A

Version 2 of the MPLS-TP model

(This annex forms an integral part of this Recommendation.)

This annex contains the previous version (version 2) of the MPLS-TP model, which was described in Clause 7 of the 2018 Edition of G.8152. Version 2 of the MPLS-TP model now is annotated with the lifecycle stereotype «*LikelyToChange*». The papyrus uml files of v2.0 is contained in the v3.0 papyrus project as a separate module. That is, the v3.0 papyrus project contains both the v3.0 module and also the v2.0 module.

A.1 OAM compound functions

OAM is done in the network by creating maintenance entities (ME). In multipoint services multiple MEs are grouped together forming a maintenance entities group (MEG); see definitions in clause 8 (MPLS-TP OAM Architecture) of [ITU-T G.8110.1].

Each MEG is terminated by a set of MEG end points (MEPs). It is also possible to perform OAM functions on a MEG by MEG intermediate points (MIPs) which allow a limited set of OAM functions along the MEs.

Table A-1 – OAM capability support

OAM function		OAM mechanism	
Compound function	MEP	Network connection monitoring	
		Tandem connection monitoring	
	MIP		(on-demand) CV
	TCS		–
Proactive measurement	Loss measurement	one-way	CCM (G.8121.1)
		two-way	LM (G.8121, G.8121.2), <i>LMDM (G.8121.2)</i>
		one-way synthetic	–
		two-way synthetic	SLM (G.8121) LM (G.8121.2) <i>LMDM (G.8121.2)</i>
	Delay measurement	one-way	IDM (G.8121)
		two-way	DM (G.8121, G.8121.2) <i>LMDM (G.8121.2)</i>
On-demand measurement	Loss measurement	two-way	LM (G.8121, G.8121.2), <i>LMDM (G.8121.2)</i>
		one-way synthetic	–
		two-way synthetic	SLM (G.8121) LM (G.8121.2) <i>LMDM (G.8121.2)</i>
	Delay measurement	one-way	IDM (G.8121, G.8121.1)
		two-way	DM (G.8121, G.8121.1, G.8121.2) <i>LMDM (G.8121.2)</i>
	Maintenance	one-way throughput test	1TH (G.8121, G.8121.1)

		On-demand loop back	CV (G.8121, G.8121.1, G.8121.2)
		On-demand link trace	CV (G.8121) CV (G.8121.2)
Proactive fault management	Continuity check and connectivity verification		CC/CV (G.8121, G.8121.2) CCM (G.8121.1)
	Remote defect indication		RDI (G.8121, G.8121.1, G.8121.2)
	Alarm indication signal		AIS (G.8121, G.8121.1, G.8121.2)
	Locked signal (Lock report)		LCK (G.8121, G.8121.1, G.8121.2)
On-demand fault management	Connectivity verification		CV (G.8121, G.8121.1, G.8121.2)
	Lock instruction		LKI (G.8121.2)
	Automatic protection switching		APS (G.8121)
	Management communication channel/ Signalling communication channel		MCC/SCC (G.8121)
NOTE 1 – OAM mechanisms for MEP are all the OAMs defined in [ITU-T G.8121] series. (The exception is APS. NCM MEP does not support APS.)			
NOTE 2 – OAM mechanism for MIP is (on-demand) CV only.			

A.1.1 MEP compound function

There are two different types of MEP compound functions:

- mandatory NCM MEPs at the boundary of a layer network, monitoring a network connection
- optional TCM MEPs in the middle of a layer network, monitoring a tandem connection.

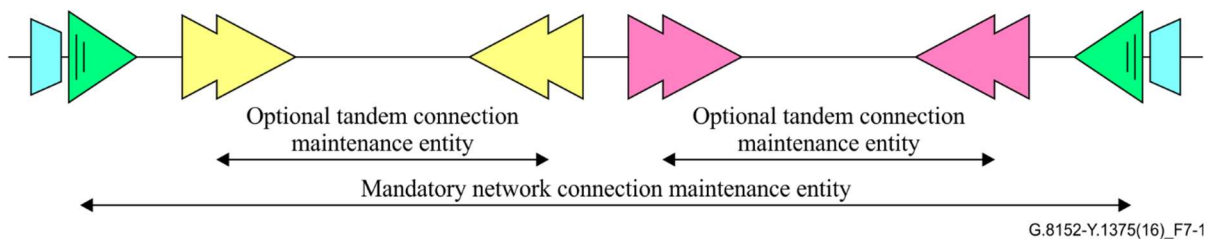

Figure A-1 – Mandatory and optional MEPs

From management point of view a MEP has the following constraints:

- A MEP can be unidirectional or bidirectional; unidirectional MEPs have a limited set of OAM functionality.
- A MEP belongs to one, and only one, MEL. MEPs terminate MEGs and each MEG is associated to one MEL.
- A MEP is addressed by one, and only one, MAC address. The MAC address (or more precise the EUI-48) is bound to a physical subsystem and one physical subsystem can hold thousands of MEP functions, and all those MEP functions share in such case one MAC address.

The MEP compound function supports three applications which are organised in "jobs":

- On-demand measurement job.
- Proactive measurement job.

A.1.1.1 MEP on-demand diagnostic function

The MEP on-demand diagnostic function exists in NCM and TCM MEPs.

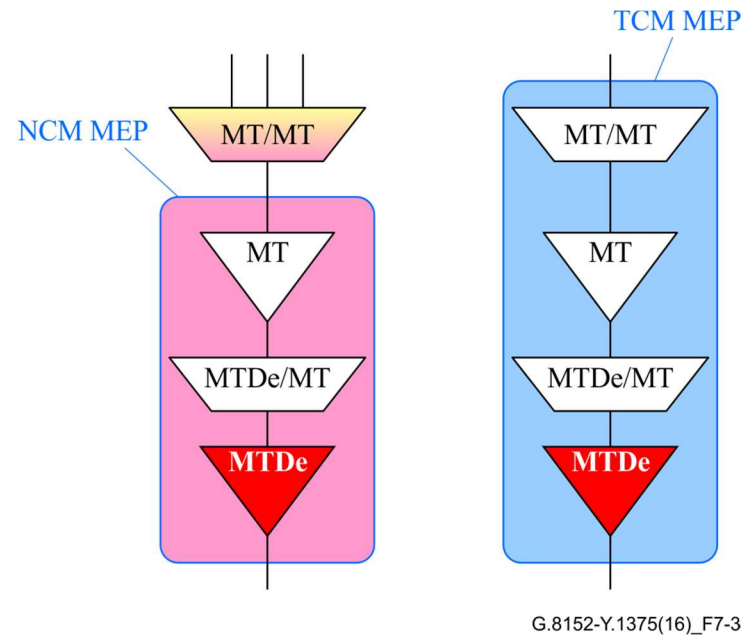

Figure A-3 – MEP on-demand diagnostic function

[ITU-T G.8121] defines the following management information (MI) for on-demand measurements and maintenance as shown in Table 7-2.

Table A-2 – On-demand measurement and maintenance MI list

Functionality	ITU-T G.8121 MTDe_TT_So_MI	ITU-T G.8121 MTDe_TT_Sk_MI	ITU-T G.8121.1 MTDe_TT_So_MI	ITU-T G.8121.1 MTDe_TT_Sk_MI	ITU-T G.8121.2 MTDe_TT_So_MI	ITU-T G.8121.2 MTDe_TT_Sk_MI
General	GAL_Enable	GAL_Enable	GAL_Enable	GAL_Enable	GAL_Enable	GAL_Enable
	TTLVALUE		TTLVALUE			
			MEP_ID	MEP_ID		
Two-way on-demand loss of frame measurement	LMO_OAM_Tool	LMO_OAM_Tool	LMO_OAM_Tool	LMO_OAM_Tool	LMO_OAM_Tool	LMO_OAM_Tool
	LMO_Start(CoS,Period)[1..M _{LMO}]		LMO_Start(CoS,Period)[1..M _{LMO}]		LMO_Start(CoS, Test_ID, Period, LMType, CountBytes)[1..M _{LMO}]	
	LMO_Intermediate_Request[1..M _{LMO}]		LMO_Intermediate_Request[1..M _{LMO}]		LMO_Intermediate_Request[1..M _{LMO}]	
	LMO_Terminate[1..M _{LMO}]		LMO_Terminate[1..M _{LMO}]		LMO_Terminate[1..M _{LMO}]	
	<i>LMO_Result(N_TF, N_LF, F_TF, F_LF)[1..M_{LMO}]</i>		<i>LMO_Result(N_TF, N_LF, F_TF, F_LF)[1..M_{LMO}]</i>		<i>LMO_Result(N_TF, N_LF, F_TF, F_LF)[1..M_{LMO}]</i>	
					<i>LMO_ReportError(Error)[1..M_{LMO}]</i>	
					<i>LMO_PeriodChanged[1..M_{LMO}]</i>	
One-way on-demand synthetic loss of frame measurement						
Two-way on-demand synthetic loss of frame measurement	SLO_OAM_Tool	SLO_OAM_Tool				
	SLO_Start(CoS,Test_ID,Length,Period)[1..M _{SLO}]					
	SLO_Intermediate_Request[1..M _{SLO}]					
	SLO_Terminate[1..M _{SLO}]					
	<i>SLO_Result(N_TF, N_LF, F_TF, F_LF)[1..M_{SLO}]</i>					
	1DMO_OAM_Tool	1DMO_OAM_Tool	1DMO_OAM_Tool	1DMO_OAM_Tool		

Table A-2 – On-demand measurement and maintenance MI list

Functionality	ITU-T G.8121 MTDe_TT_So_MI	ITU-T G.8121 MTDe_TT_Sk_MI	ITU-T G.8121.1 MTDe_TT_So_MI	ITU-T G.8121.1 MTDe_TT_Sk_MI	ITU-T G.8121.2 MTDe_TT_So_MI	ITU-T G.8121.2 MTDe_TT_Sk_MI
One-way on-demand frame delay measurement	1DMo_Start (CoS,Test_ID,Length,Period)[1...M _{1DMo}]	1DMo_Start(Test_ID)[1...M _{1DMo}]	1DMo_Start (CoS,,Length,Period)[1...M _{1DMo}]	1DMo_Start[1...M _{1DMo}]		
	1DMo_Terminate[1...M _{1DMo}]	1DMo_Terminate[1...M _{1DMo}]	1DMo_Terminate[1...M _{1DMo}]	1DMo_Terminate[1...M _{1DMo}]		
Two-way on-demand frame delay measurement	DMo_OAM_Tool	DMo_OAM_Tool	DMo_OAM_Tool	DMo_OAM_Tool	DMo_OAM_Tool	DMo_OAM_Tool
	DMo_Start (CoS,Test_ID,Length,Period)[1...M _{DMo}]		DMo_Start (CoS,Length,Period)[1...M _{DMo}]		DMo_Start(CoS, Test_ID, Length, Period, CopyPad)[1...M _{DMo}]	
	DMo_Intermediate_Request[1...M _{LMo}]		DMo_Intermediate_Request[1...M _{LMo}]		DMo_Intermediate_Request[1...M _{LMo}]	
	DMo_Terminate[1...M _{DMo}]		DMo_Terminate[1...M _{DMo}]		DMo_Terminate[1...M _{DMo}]	
	<i>DMo_Result(count,B_FD[],F_FD[],N_FD[])[1...M_{DMo}]</i>	<i>1DMo_Result(count,N_FD[])[1...M_{DMo}]</i>	<i>DMo_Result(count,B_FD[],F_FD[],N_FD[])[1...M_{DMo}]</i>		<i>DMo_Result(count, B_FD[], F_FD[], N_FD[])[1...M_{DMo}]</i>	
					<i>DMo_ReportError(Error)[1...M_{DMo}]</i>	
					<i>DMo_PeriodChanged[1...M_{DMo}]</i>	
Two-way on-demand frame loss / frame delay measurement					LMDMo_OAM_Tool (Note1)	
					DMo_OAM_Tool (Note2)	
					LMDMo_Start(CoS, Test_ID, Length, Period, LMType, CountBytes, CopyPad)[1...M _{LMDMo}]	
					LMDMo_IntermediateReport[1...M _{LMDMo}]	
					LMDMo_Terminate[1...M _{LMDMo}]	
					<i>LMDMo_Result(N_TF, N_LF, F_TF, F_LF)[1...M_{LMDMo}]</i>	

Table A-2 – On-demand measurement and maintenance MI list

Functionality	ITU-T G.8121 MTDe_TT_So_MI	ITU-T G.8121 MTDe_TT_Sk_MI	ITU-T G.8121.1 MTDe_TT_So_MI	ITU-T G.8121.1 MTDe_TT_Sk_MI	ITU-T G.8121.2 MTDe_TT_So_MI	ITU-T G.8121.2 MTDe_TT_Sk_MI
					<i>DMo_Result(count, B_FD[], F_FD[], N_FD[])[1...MDMo]</i>	
					<i>LMO_ReportError(Error)[1...MLMo]</i>	
					<i>LMO_PeriodChanged[1...MLMo]</i>	
On-demand loop back	CV_OAM_Tool	CV_OAM_Tool	CV_OAM_Tool	CV_OAM_Tool	CV_OAM_Tool	CV_OAM_Tool
	CV_Series()		CV_Series (TTL,CoS,N,Length,Period)		CV_Series (Session_ID, Count, Period, CoS, Size, ValidateFEC, ValidateReverse, TargetFECStack)	
	<i>CV_Series_Result()</i>		<i>CV_Series_Result(REC,ERR,OO)</i>		FEC_Checking	FEC_Checking
					Target_FEC	FEC_Checking
					<i>CV_Series_Result(Session_ID, Rcv, OOO, FWErr, BWErr)</i>	
					<i>CV_FWErr(Session_ID, Seq, RC, SubRC, ErrTLV)</i>	
					<i>CV_BWErr(Session_ID, Seq, RC, SubRC, ErrTLV)</i>	
On-demand lock instruct	Admin_State	<i>Admin_State_Request</i>			Admin_State	<i>Admin_State_Request</i>
	Lock_Instruct_Enable				Lock_Instruct_Enable	
	LI_Period				LI_Period	
	LI_MEPID				LI_MEPID	
	LI_CoS				LI_CoS	

Table A-2 – On-demand measurement and maintenance MI list

Functionality	ITU-T G.8121 MTDe_TT_So_MI	ITU-T G.8121 MTDe_TT_Sk_MI	ITU-T G.8121.1 MTDe_TT_So_MI	ITU-T G.8121.1 MTDe_TT_Sk_MI	ITU-T G.8121.2 MTDe_TT_So_MI	ITU-T G.8121.2 MTDe_TT_Sk_MI
One-way on-demand throughput test	1TH_OAM_Tool	1TH_OAM_Tool	1TH_OAM_Tool	1TH_OAM_Tool		
	1TH_Start (CoS, Length, Period)	1TH_Start	1TH_Start (CoS, Pattern, Length, Period)	1TH_Start (Period)		
	1TH_Terminate	1TH_Terminate	1TH_Terminate	1TH_Terminate		
	<i>1TH_Result(Sent)</i>	<i>1TH_Result(REC, CRC, BE R, OO)</i>	<i>1TH_Result(Sent)</i>	<i>1TH_Result(REC, CRC, BE R, OO)</i>		
On-demand link trace	CV_OAM_Tool	CV_OAM_Tool	CV_OAM_Tool	CV_OAM_Tool	CV_OAM_Tool	CV_OAM_Tool
					CV_Trace (Session_ID, CoS, ValidateFEC, ValidateReverse, TargetFECStack)	
					<i>CV_Trace_Result (Session_ID, Result)</i>	
					<i>CV_FWErr(Session_ID, Seq, RC, SubRC, ErrTLV)</i>	
					<i>CV_BWErr(Session_ID, Seq, RC, SubRC, ErrTLV)</i>	
On-demand test	CV_OAM_Tool	CV_OAM_Tool	CV_OAM_Tool	CV_OAM_Tool		
			CV_Test (CoS, Pattern, Length, Period)			
			CV_Terminate			
			<i>CV_Test_Result(Sent, REC, REC, ERR, OO)</i>			

A.1.1.2 MEP proactive measurement function

The MEP proactive measurement function exists in NCM and TCM MEPs.

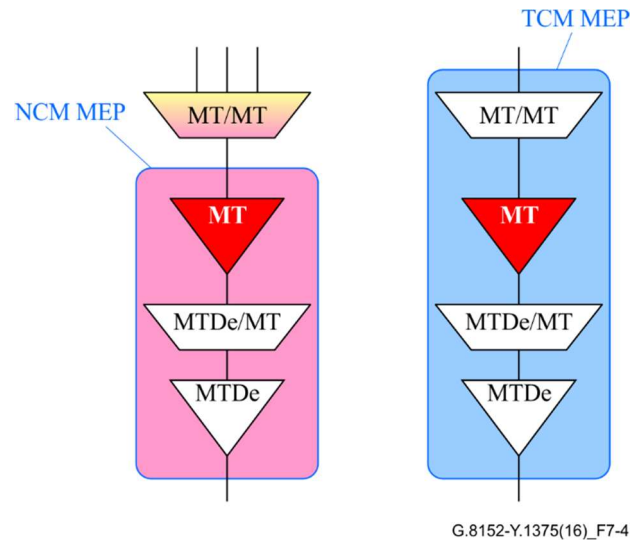

Figure A-4 – MEP proactive measurement function

[ITU-T G.8121] defines the following management information (MI) for pro-active measurements:

Table A-3 – Pro-active measurement MI list

Functionality	ITU-T G.8121 MT_TT_So_MI	ITU-T G.8121 MT_TT_Sk_MI	ITU-T G.8121.1 MT_TT_So_MI	ITU-T G.8121.1 MT_TT_Sk_MI	ITU-T G.8121.2 MT_TT_So_MI	ITU-T G.8121.2 MT_TT_Sk_MI
General	GAL_Enable	GAL_Enable	GAL_Enable	GAL_Enable	GAL_Enable	GAL_Enable
	TTLVALUE		TTLVALUE		TTLVALUE	
	MEG_ID	MEG_ID	MEG_ID	MEG_ID		
	MEP_ID	PeerMEP_ID	MEP_ID	PeerMEP_ID	MEP_ID	PeerMEP_ID
		AIS_OAM_Tool				
		LCK_OAM_Tool				
						PM_ClearError
						PM_Responder_Enable
Continuity check and Connectivity Verification	CC_OAM_Tool	CC_OAM_Tool	CC_OAM_Tool	CC_OAM_Tool	CC_OAM_Tool	CC_OAM_Tool
	RDI_OAM_Tool	RDI_OAM_Tool	RDI_OAM_Tool	RDI_OAM_Tool	RDI_OAM_Tool	RDI_OAM_Tool
	CC_Enable (Note1)	CC_Enable (Note1)	CC_Enable (Note2)	CC_Enable	CC_Enable[1...Mcccv]	

Table A-3 – Pro-active measurement MI list

Functionality	ITU-T G.8121 MT_TT_So_MI	ITU-T G.8121 MT_TT_Sk_MI	ITU-T G.8121.1 MT_TT_So_MI	ITU-T G.8121.1 MT_TT_Sk_MI	ITU-T G.8121.2 MT_TT_So_MI	ITU-T G.8121.2 MT_TT_Sk_MI
	CVp_Enable (Note1)	CVp_Enable (Note1)			CVp_Enable[1...Mcccvcv]	
					CCCV_Mode[1...Mcccvcv]	
	MEP_ID	PeerMEP_ID	MEP_ID	PeerMEP_ID	MEP_ID[1...Mcccvcv]	PeerMEP_ID[1...Mcccvcv]
	CC_CoS	CC_CoS	CC_CoS	CC_CoS	CC_CoS[1...Mcccvcv]	CC_CoS[1...Mcccvcv]
	CC_Period	CC_Period	CC_Period	CC_Period	CC_Period	CC_Period
		Get_SvdCC		Get_SvdCC		Get_SvdCC[1...Mcccvcv]
		SvdCC		SvdCC		SvdCC
	<p><i>NOTE 1 – MI_CC_Enable and MI_CVp_Enable are used to enable CC and CV functions respectively. The possible combinations are:</i></p> <ul style="list-style-type: none"> – no CC function and no CV function: MI_CC_Enable = false and MI_CVp_Enable = false – CC-only function: MI_CC_Enable = true and MI_CVp_Enable = false – CC and CV functions: MI_CC_Enable = true and MI_CVp_Enable = true <p><i>NOTE 2 – MI_CVp_Enable defined in [ITU-T G.8121] is automatically configured true by setting MI_CC_Enable true.</i></p>					
one-way pro-active loss of frame measurement using CC	CC_OAM_Tool	CC_OAM_Tool	CC_OAM_Tool	CC_OAM_Tool		
	1LMp_Enable	1LMp_Enable	LMC_Enable	LMC_Enable		
			MEP_ID	PeerMEP_ID		
			CC_CoS	CC_CoS		
two-way pro-active loss of frame measurement			CC_Period	CC_Period		
	Lmp_OAM_Tool	Lmp_OAM_Tool	Lmp_OAM_Tool	Lmp_OAM_Tool	Lmp_OAM_Tool	Lmp_OAM_Tool
	Lmp_Enable[1...MLMp]	Lmp_Enable[1... MLMp]	Lmp_Enable[1...MLMp]	Lmp_Enable[1... MLMp]	Lmp_Enable[1...MLMp]	Lmp_Enable[1... MLMp]
	Lmp_Period[1...MLMp]		Lmp_Period[1...MLMp]		Lmp_Period[1...MLMp]	
	Lmp_CoS[1...MLMp]	Lmp_CoS[1... MLMp]	Lmp_CoS[1...MLMp]	Lmp_CoS[1... MLMp]	Lmp_CoS[1...MLMp]	
					Lmp_Test_ID[1...MLMp]	
					Lmp_LMType[1...MLMp]	
				Lmp_CountBytes[1...MLMp]		

Table A-3 – Pro-active measurement MI list

Functionality	ITU-T G.8121 MT_TT_So_MI	ITU-T G.8121 MT_TT_Sk_MI	ITU-T G.8121.1 MT_TT_So_MI	ITU-T G.8121.1 MT_TT_Sk_MI	ITU-T G.8121.2 MT_TT_So_MI	ITU-T G.8121.2 MT_TT_Sk_MI
					<i>Lmp_PeriodChanged[1... MLMp]</i>	
						<i>Lmp_ReportError(Error) [1...MLMp]</i>
		LM_DEGM		LM_DEGM		
		LM_M		LM_M		
		LM_DEGTHR		LM_DEGTHR		
		LM_TFMIN		LM_TFMIN		
one-way pro- active synthetic loss of frame measurement	1SLp_OAM_Tool	1SLp_OAM_Tool				
	1SLp_Enable[1...M _{1SLp}]	1SLp_Enable[1...M _{1SLp}]				
	1SLp_Period[1...M _{1SLp}]					
	1SLp_Test_ID[1...M _{1SLp}]	1SLp_Test_ID[1...M _{1SLp}]				
	1SLp_Length[1...M _{1SLp}]					
	1SLp_CoS[1...M _{1SLp}]					
two-way pro- active synthetic loss of frame measurement	SLp_OAM_Tool	SLp_OAM_Tool			(covered by DMp)	(covered by DMp)
	SLp_Enable[1...M _{SLp}]	SLp_Enable[1... M _{SLp}]				
	SLp_Period[1...M _{SLp}]					
	SLp_Test_ID[1...M _{SLp}]					
	SLp_Length[1...M _{SLp}]					
	SLp_CoS[1...M _{SLp}]	SLp_CoS[1... M _{SLp}]				
one-way pro- active frame delay measurement	1DMp_OAM_Tool	1DMp_OAM_Tool				
	1DMp_Enable[1...M _{1DMp}]	1DMp_Enable[1...M _{1DMp}]				
	1DMp_Period[1...M _{1DMp}]					
	1DMp_Test_ID[1...M _{1DMp}]	1DMp_Test_ID[1...M _{1DMp}]				
	1DMp_Length[1...M _{1DMp}]					
	1DMp_CoS[1...M _{1DMp}]					
	DMp_OAM_Tool	DMp_OAM_Tool	DMp_OAM_Tool	DMp_OAM_Tool	DMp_OAM_Tool	DMp_OAM_Tool

Table A-3 – Pro-active measurement MI list

Functionality	ITU-T G.8121 MT_TT_So_MI	ITU-T G.8121 MT_TT_Sk_MI	ITU-T G.8121.1 MT_TT_So_MI	ITU-T G.8121.1 MT_TT_Sk_MI	ITU-T G.8121.2 MT_TT_So_MI	ITU-T G.8121.2 MT_TT_Sk_MI
two-way pro-active frame delay measurement	Dmp_Enable[1...M _{DMP}]	Dmp_Enable[1... M _{DMP}]	Dmp_Enable[1...M _{DMP}]	Dmp_Enable[1... M _{DMP}]	Dmp_Enable[1...M _{DMP}]	Dmp_Enable[1... M _{DMP}]
	Dmp_Period[1...M _{DMP}]		Dmp_Period[1...M _{DMP}]		Dmp_Period[1...M _{DMP}]	
	Dmp_Test_ID[1...M _{DMP}]		Dmp_Test_ID[1...M _{DMP}]		Dmp_Test_ID[1...M _{DMP}]	
	Dmp_CoS[1...M _{DMP}]	Dmp_CoS[1... M _{DMP}]	Dmp_CoS[1...M _{DMP}]	Dmp_CoS[1... M _{DMP}]	Dmp_CoS[1...M _{DMP}]	
	Dmp_Length[1...M _{DMP}]		Dmp_Length[1...M _{DMP}]		Dmp_Length[1...M _{DMP}]	
					Dmp_CopyPad[1...M _{DMP}]	
					<i>Dmp_PeriodChanged[1... M_{LMp}]</i>	
					<i>Dmp_ReportError(Error) [1...M_{DMP}]</i>	
Fault cause list		cSSF cLCK cLOC cMMG cUNM cUNP cUNC cDEG cRDI		cSSF cLCK cLOC cMMG cUNM cUNP cUNC cDEG cRDI		cSSF cLCK cLOC[] cMMG cUNM cUNC cDEG cRDI

Table A-3 – Pro-active measurement MI list

Functionality	ITU-T G.8121 MT_TT_So_MI	ITU-T G.8121 MT_TT_Sk_MI	ITU-T G.8121.1 MT_TT_So_MI	ITU-T G.8121.1 MT_TT_Sk_MI	ITU-T G.8121.2 MT_TT_So_MI	ITU-T G.8121.2 MT_TT_Sk_MI
Performance primitive list		pN_LF[1...P] pN_TF[1...P] pF_LF[1...P] pF_TF[1...P] pF_DS pN_DS pB_FD[1...P] pB_FD[1...P] pN_FD[1...P] pN_FD[1...P] pF_FD[1...P] pF_FD[1...P]		pN_LF pN_TF pF_LF pF_TF pF_DS pN_DS		pN_LF[1...P] pN_TF[1...P] pF_LF[1...P] pF_TF[1...P] pF_DS pN_DS pB_FD[1...P] pB_FD[1...P] pN_FD[1...P] pN_FD[1...P] pF_FD[1...P] pF_FD[1...P]

A.1.1.3 MEP configuration function

The MEP configuration function exists in NCM and TCM MEPs.

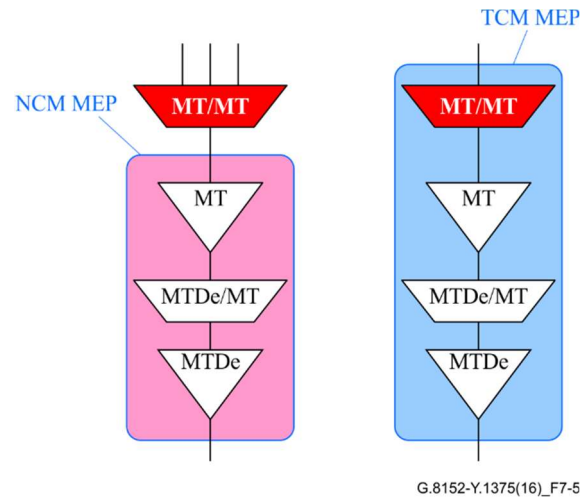

Figure A-5 – MEP configuration function

[ITU-T G.8121] defines the following management information (MI) for configuring a MEP, as given in Table 7-4.

Table 0A-4 – MEP configuration MI list

Functionality	ITU-T G.8121 MT/MT_A_So_MI	ITU-T G.8121 MT/MT_A_Sk_MI	ITU-T G.8121.1 MT/MT_A_So_MI	ITU-T G.8121.1 MT/MT_A_Sk_MI	ITU-T G.8121.2 MT/MT_A_So_MI	ITU-T G.8121.2 MT/MT_A_Sk_MI
General	GAL_Enable	GAL_Enable				
	TTLVALUE					
Lock	Admin_State	Admin_State				
	LCK_Period	LCK_Period				
	LCK_CoS	LCK_CoS				
	LCK_OAM_Tool	LCK_OAM_Tool				
Alarm indication signal (Note)	AIS_Period	AIS_Period			Local_Defect	
	AIS_CoS	AIS_CoS				
	AIS_OAM_Tool	AIS_OAM_Tool				
Client signal fail	CSF_Tool	CSF_Tool				
	CSF_Period					
	CSF_CoS					
	CSF_Enable					
	CSFrdfdiEnable	CSFrdfdiEnable				
		CSF_Reported				
Automatic protection switching	APS_OAM_Tool	APS_OAM_Tool				
	APS_CoS					

NOTE – MIs for AIS at source are configured at server MEP.

A.1.2 MIP compound function

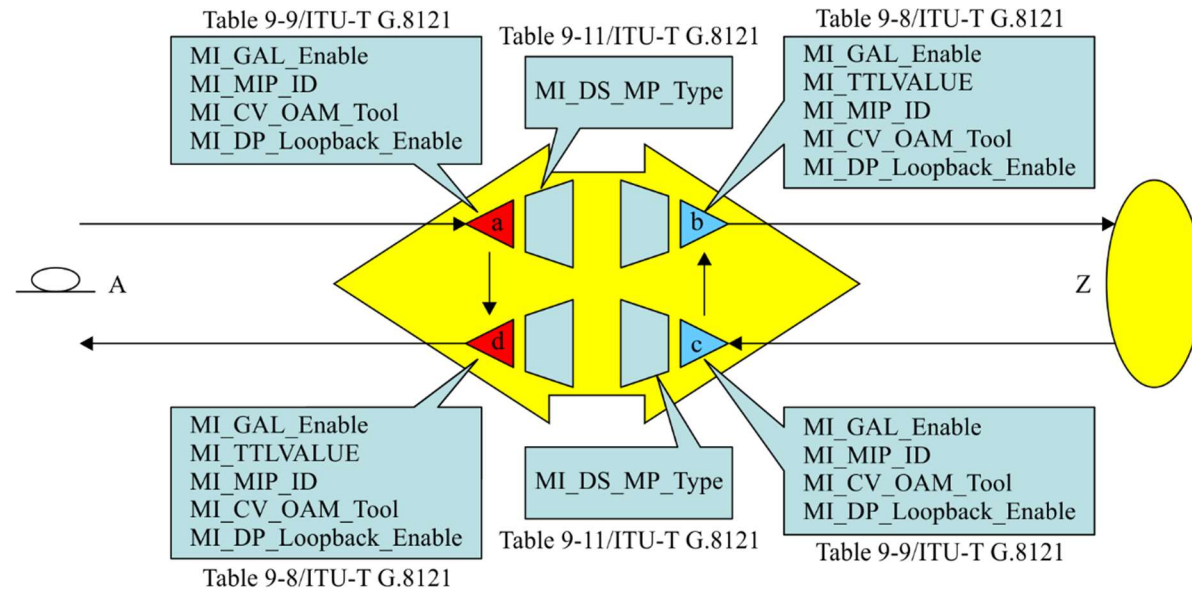

G.8152-Y.1375(16)_F7-6

Figure A-6 – MIP configuration parameters

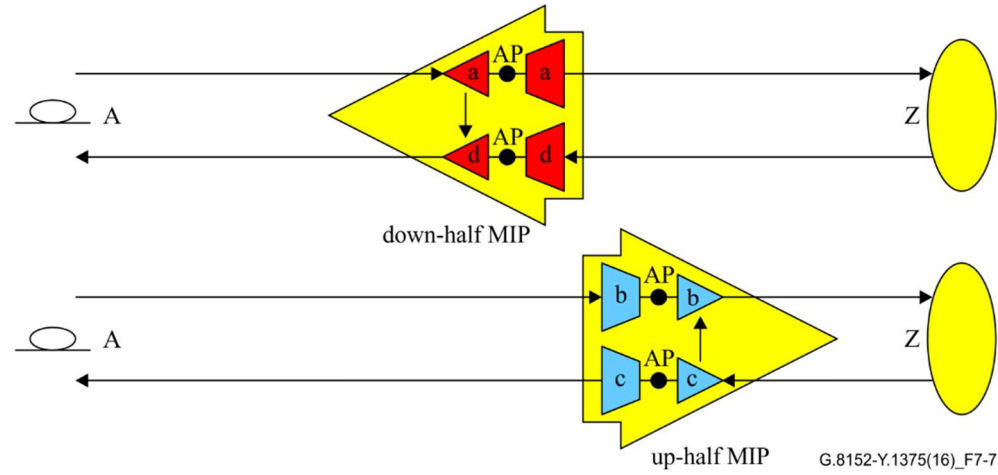

Figure A-7 – "half MIP" compound function

The management information (MI) of the MIP compound function (defined in [ITU-T G.8121/Y.1381]) is mapped to the MipBidirectional object class.

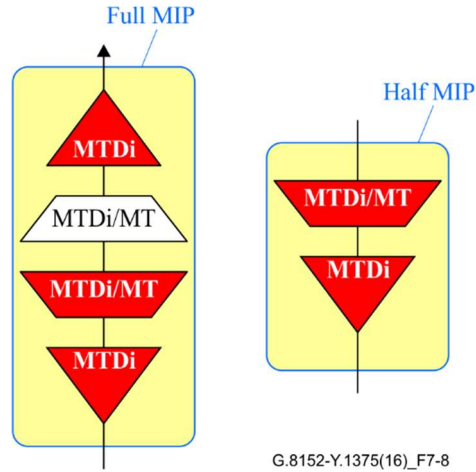

Figure A-8 – MIP/half MIP configuration function

[ITU-T G.8121/Y.1381] defines the following management information (MI) for configuring a MIP, as given in Table 7-5.

Table 0A-5 – MIP configuration MI list

Functionality	ITU-T G.8121 MTDi_TT_So_MI	ITU-T G.8121 MTDi_TT_Sk_MI	ITU-T G.8121.1 MTDi_TT_So_MI	ITU-T G.8121.1 MTDi_TT_Sk_MI	ITU-T G.8121.2 MTDi_TT_So_MI	ITU-T G.8121.2 MTDi_TT_Sk_MI
General	GAL_Enable	GAL_Enable				
	TTLVALUE					
	MIP_ID	MIP_ID				
		DS_MP_Type [Note]				
	[Note] DS_MP_type is configured at MTDi/MT_A_Sk					
On-demand CV	CV_OAM_Tool	CV_OAM_Tool			Target_FEC	

A.2 Fault management

FFS.

A.3 Performance monitoring

Performance monitoring allows measurement of different performance parameters like frame loss ratio, frame delay and frame delay variation.

A.3.1 Loss Measurement

The frame loss measurement (LM) provides performance data that is based on the lost frames between the ingress and the egress of a maintenance entity (ME); i.e., between two maintenance group end points (MEPs).

LM is restricted to MEGs which have only a single ME.

The following LM functions are defined:

- two-way on-demand LM
- one-way on-demand synthetic LM
- two-way on-demand synthetic LM
- two-way proactive LM
- one-way proactive synthetic LM
- two-way proactive synthetic LM.

The single-ended on-demand LM function is managed only at the source MEP. The sink MEP does not need any management.

The dual-ended pro-active LM function is managed at source and sink MEP.

A.3.2 Delay measurement

The frame delay measurement (DM) provides performance data that is based on the delay of the frames between the ingress and the egress of a maintenance entity (ME); i.e., between two maintenance group end points (MEPs).

The following DM functions are defined:

- one-way on-demand DM
- two-way (round-trip) on-demand DM.
- one-way proactive DM
- two-way (round-trip) proactive DM.

The one-way DM function is started at the source MEP and enabled at the sink MEP.

The two-way DM function is managed only at the source MEP. The sink MEP does not need any management.

A.4 MPLS-TP multiplexing

This clause maps the MPLS-TP multiplexing related MIs to the corresponding object classes.

The MPLS-TP multiplexing configuration function exists only in MT TTP and MT CTP.

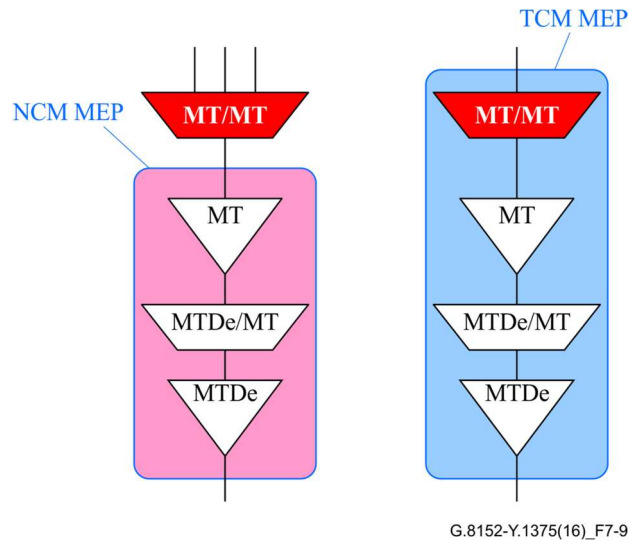

Figure A-9 – MPLS-TP multiplexing configuration function

[ITU-T G.8121] defines the following management information (MI) for configuring the MPLS-TP multiplexing function, as given in Table 7-5bis.

Table A-5bis – Mapping of multiplexing related MI to ITU-T G.8152 artefacts

Functionality	ITU-T G.8121 MT/MT_A_So_MI	ITU-T G.8121 MT/MT_A_Sk_MI
TTP associated MI	Label[1...M]	Label[1...M]
	LSPTType[1...M]	LSPTType[1...M]
	CoS[1...M]	CoS[1...M]
	PHB2TCMapping[1...M]	TC2PHBMapping[1...M]
	QoSEncodingMode[1...M]	QoSDecodingMode[1...M]
	Mode	Mode
CTP associated MI		

A.5 Connection function

This clause maps the connection function related MIs to the corresponding object classes.

Table A-6 – Mapping of connection function related MI to ITU-T G.8152 artefacts

Functionality	MT_C_MI	ITU-T G.8152
General connection management	Create_MC	
	Modify_MC	
	Delete_MC	
Individual connection point management	MT_C_MP per input and output connection point	
	<i>for further study</i>	
Individual connection management	MT_C_MP per matrix connection:	
	MT_C_MI_ConnectionType	
	MT_C_MI_Return_CP_ID	

Table A-6 – Mapping of connection function related MI to ITU-T G.8152 artefacts

Functionality	MT_C_MI	ITU-T G.8152
	MT_C_MI_ConnectionPortIds	
SNCP configuration	MT_C_MP per SNC/S protection process:	
	<i>for further study</i>	

A.5.1 Linear protection function

The MPLS-TP linear protection function is defined in [ITU-T G.8131]. The related "Management Information" is listed in [ITU-T G.8121].

This function is modelled by the MT_SNCP_Group object class.

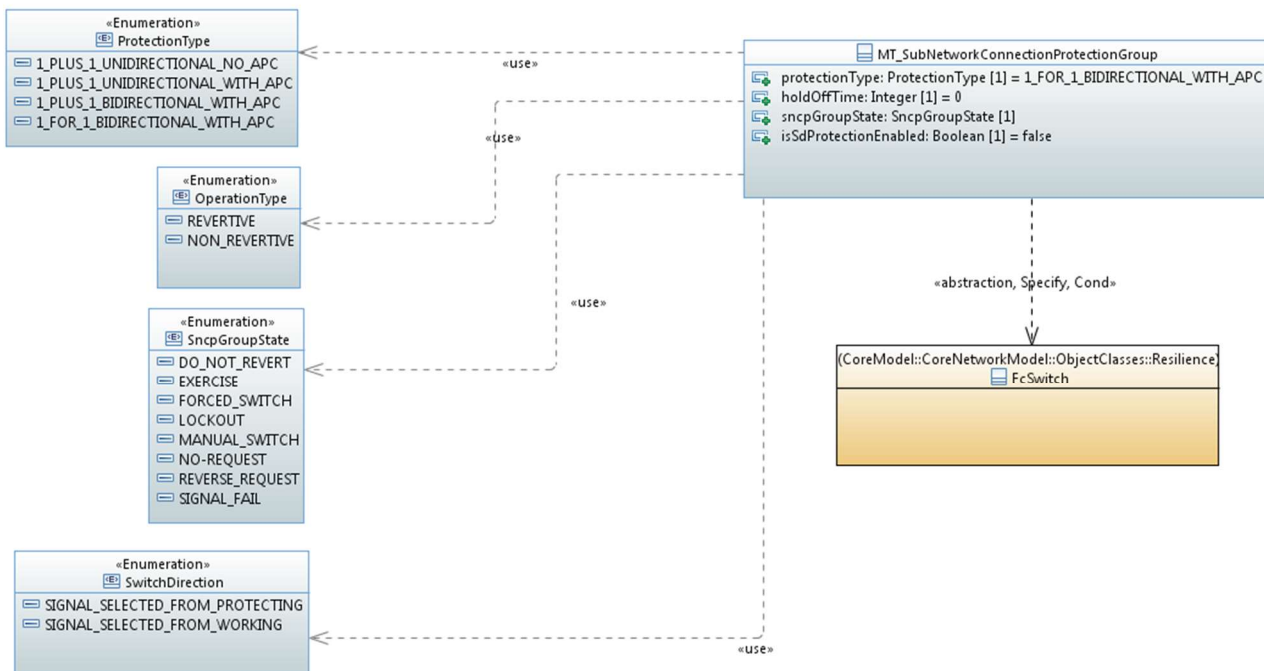

NOTE – This figure is also available from the ITU website [here](#).

Figure A-10 – MPLS-TP linear protection

A.6 SCC/MCC access function

Signalling communication channel (SCC) and management communication channel (MCC) can be accessed when the containing LSP is terminated. Each channel is able to transport IPv4, IPv6 and OSI structured signals. The diamonds in Figure 7-11 represent traffic shaping and conditioning functions that may be needed to prevent the SCC/MCC forwarding points from exceeding their committed bandwidth in congestion situations.

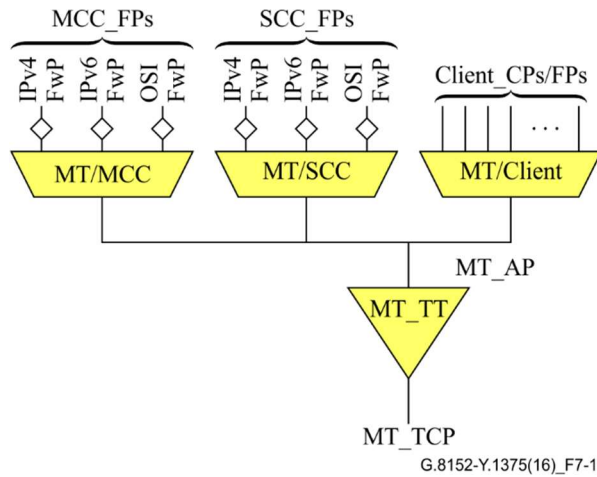
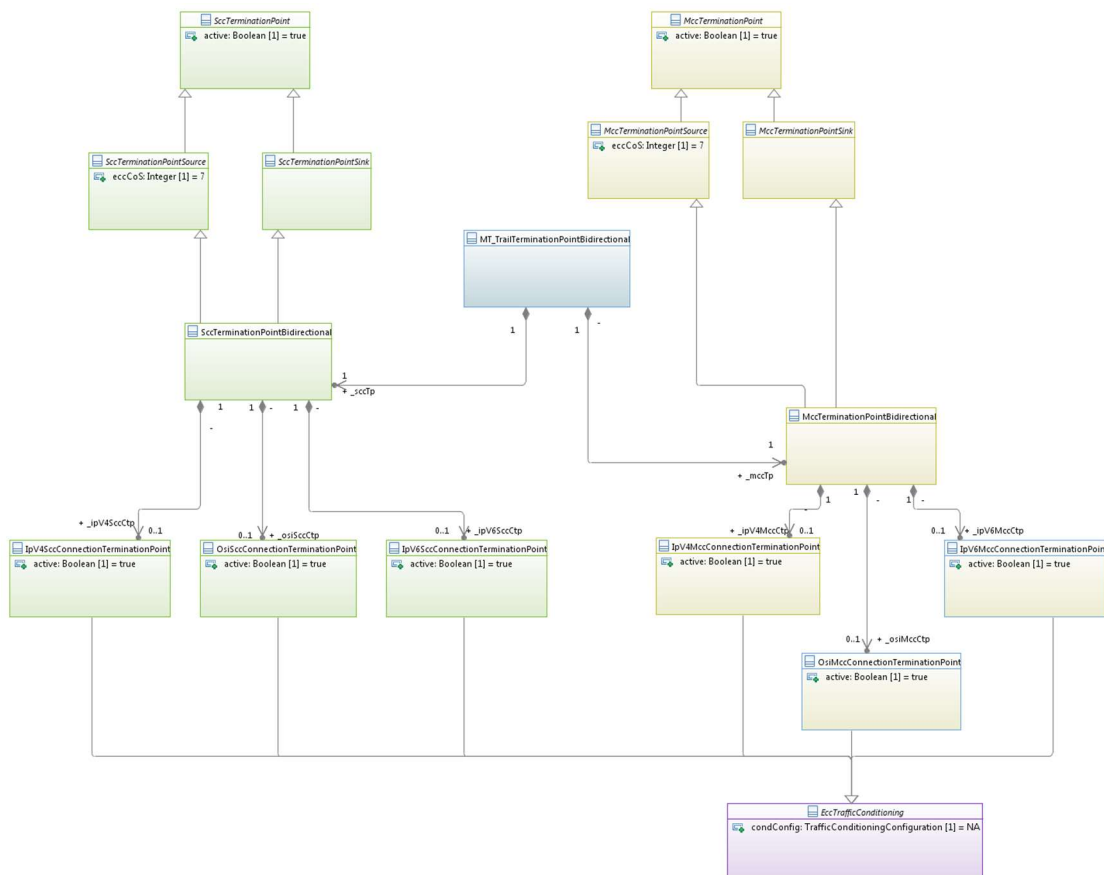

Figure A-11 – MT/SCC_A function, MT/MCC_A function, and MT/client_A function (Copy from Figure 10-5 [ITU-T G.8121])

SCC and MCC access are modelled using the same pattern. Only the bidirectional SCC/MCC termination point (TP) can be instantiated. Each termination point contains one connection termination point (CTP) for IPv4 access, one CTP for IPv6 access and one CTP for OSI access. These CTPs have the capability to shape and condition the communication signals.

The management of the SCC/MCC access function has been added to the bidirectional MT TTP.

Figure 7-12 contains the related class diagram.



NOTE – This figure is also available from the ITU website [here](#).

Figure A-12 – SCC/MCC access class diagram

Appendix I

UML modelling guidelines

(This appendix does not form an integral part of this Recommendation.)

See Annex A of [ITU-T G.7711].

NOTE – The UML modelling guidelines specified in the 7/2013 version of this Recommendation has been enhanced and normatively specified in Annex A of [ITU-T G.7711].

Appendix II

MI grouping and mapping

(This appendix does not form an integral part of this Recommendation.)

This Appendix lists (from [ITU-T G.8121]) all atomic functions together with their MI. It is structured according to clause 9 of [ITU-T G.8121].

Conventions used in the tables:

- Atomic functions having the same list of MI are grouped.
- Fault and performance MIs are not shown.
- MI of adaptation functions are identified as "client layer related" (**blue**) or "server layer related" (**red**).

II.1 MPLS-TP connection function (MT_C)

Table II-1 – MI groupings of the MPLS-TP connection function

Symbol	Management information	Managed object class
MPLS-TP connection function		
	MI_MatrixControl <i>per matrix connection:</i> MI_ConnectionType MI_Return_CP_ID MI_ConnectionPortIds <i>per SNCP protection group:</i> MI_PS_WorkingPortId MI_PS_ProtectionPortId MI_PS_ProtType MI_PS_OperType MI_PS_HoTime MI_PS_WTR MI_PS_ExtCMD MI_PS_BridgeType MI_PS_SD_Protection	

II.2 MPLS-TP termination function (MT_TT)

Table II-2 – MI groupings of the MPLS-TP termination function

Symbol	Management information	Managed object class
MPLS-TP (MT) trail termination source function		
	MI_GAL_Enable MI_TTLVALUE MI_MEG_ID MI_MEP_ID MI_CC_OAM_Tool MI_RDI_OAM_Tool MI_CC_Enable MI_CVp_Enable MI_CC_CoS MI_CC_Period MI_LMp_OAM_Tool MI_LMp_Enable[i] MI_LMp_Period[i] MI_LMp_CoS[i] MI_DMp_OAM_Tool MI_DMp_Enable[i] MI_DMp_Period[i] MI_DMp_Test_ID[i] MI_DMp_CoS[i] MI_DMp_Length[i] MI_1DMp_OAM_Tool MI_1DMp_Enable[i] MI_1DMp_Period[i] MI_1DMp_Test_ID[i] MI_1DMp_Length[i] MI_1DMp_CoS[i] MI_SLp_OAM_Tool MI_SLp_Enable[i] MI_SLp_Period[i] MI_SLp_Test_ID[i] MI_SLp_Length[i] MT_TT_So_MI_SLp_CoS[i]	
G.8121.1 specific	MI_LMC_Enable	
G.8121.2 specific	MI_CCCV_Mode[i] MI_Local_Discr MI_DMp_CopyPad[i] MI_LMp_Test_ID[i] MI_LMp_LMType[1...MLMp] MI_LMp_CountBytes[i]	
MPLS-TP (MT) trail termination sink function		

Table II-2 – MI groupings of the MPLS-TP termination function

Symbol	Management information	Managed object class
	MI_GAL_Enable MI_MEG_ID MI_PeerMEP_ID MI_CC_OAM_Tool MI_RDI_OAM_Tool MI_CC_Enable MI_CVp_Enable MI_CC_Period MI_CC_CoS MI_Get_SvdCC MI_LMp_OAM_Tool MI_LMp_Enable[i] MI_LMp_CoS[i] MI_LM_DEGM MI_LM_M MI_LM_DEGTHR MI_LM_TFMIN MI_DMp_OAM_Tool MI_DMp_Enable[i] MI_DMp_CoS[i] MI_1DMp_OAM_Tool MI_1DMp_Enable[i] MI_1DMp_Test_ID[i] MI_SLp_OAM_Tool MI_SLp_Enable[i] MI_SLp_CoS[i] MI_AIS_OAM_Tool MI_LCK_OAM_Tool MI_1second	
G.8121.1 specific	MI_LMC_Enable	
G.8121.2 specific	MI_CCCV_Mode[i] MI_Remote_Discr[i] MI_PM_ClearError MI_PM_Responder_Enable	

II.3 MPLS-TP to MPLS-TP adaptation function (MT/MT_A)

Table II-3 – MI Groupings of the MPLS-TP to MPLS-TP adaptation function

Symbol	Management information (blue: client layer related red: server layer related)	Managed object class
MPLS-TP to MPLS-TP adaptation source function		

Table II-3 – MI Groupings of the MPLS-TP to MPLS-TP adaptation function

Symbol	Management information (blue: client layer related red: server layer related)	Managed object class
	<p>MI_Active MI_Admin_State MI_Label[i] MI_LSPTType[i] MI_CoS[i] MI_PHB2TCMapping[i] MI_QoSEncodingMode[i] MI_Mode MI_LCK_Period[i] MI_LCK_CoS[i] MI_LCK_OAM_Tool[i] MI_GAL_Enable[i] (NOTE – Should be MI_GAL_Enable set double (Server and client)?) MI_APS_CoS MI_APS_OAM_Tool</p>	
MPLS-TP to MPLS-TP adaptation sink function		
	<p>MI_Active MI_AdminState MI_Label[i] MI_LSPTType[i] MI_CoS[i] MI_TC2PHBMapping[i] MI_QoSDecodingMode[i] MI_Mode MI_AIS_Period[i] MI_AIS_CoS[i] MI_AIS_OAM_Tool[i] MI_LCK_Period[i] MI_LCK_CoS[i] MI_LCK_OAM_Tool[i] MI_APS_OAM_Tool MI_GAL_Enable [i] (NOTE – Should be MI_GAL_Enable set double (Server and cliene)?)</p>	
G.8121.2 specific	MI_Local_Defect[i]	

II.4 MT diagnostic functions (MTDe and MTDi)

Table II-4 – MI groupings of the MT diagnostic functions

Symbol	Management information	Managed object class
MT diagnostic trail termination source function for MEP (MTDe_TT_So)		

Table II-4 – MI groupings of the MT diagnostic functions

Symbol	Management information	Managed object class
	MI_GAL_Enable MI_TTLVALUE MI_CV_OAM_Tool MI_CV_Series () MTDe_TT_So_MI_1TH_OAM_Tool MI_1TH_Start (CoS,Length,Period) MI_1TH_Terminate MI_LMo_OAM_Tool MI_LMo_Start(CoS,Period) [i] MI_LMo_Terminate[i] MI_DMo_OAM_Tool MI_DMo_Start (CoS,Test_ID,Length,Period)[i] MI_DMo_Terminate[i] MI_1DMo_OAM_Tool MI_1DMo_Start(CoS,Test_ID,Length,Period)[i] MI_1DMo_Terminate[i] MI_SLo_OAM_Tool MI_SLo_Start (CoS,Test_ID,Length,Period)[i] MI_SLo_Terminate[i] MI_Admin_State MI_Lock_Instruct_Enable MI_DP_Loopback_Enable	
G.8121.1 specific	MI_MEP_ID MI_CV_Series (Target MEP/MIP ID, CoS, N, Length, Period) MI_CV_Test(CoS, Pattern, Length, Period)	

Table II-4 – MI groupings of the MT diagnostic functions

Symbol	Management information	Managed object class
G.8121.2 specific	MI_CV_Series (Session_ID, Count, Period, CoS, Size, ValidateFEC, ValidateReverse, TargetFECStack) MI_CV_Trace (Session_ID, CoS, ValidateFEC, ValidateReverse, TargetFECStack) MI_FEC_Checking MI_Target_FEC MI>Ifnum MI_MTU MI_DMo_Start(CoS, Test_ID, Length, Period, CopyPad)[i] MI_LMo_Start(CoS, Test_ID, Period, LMType, CountBytes)[i] LMDMo_Start(CoS, Test_ID, Length, Period, LMType, CountBytes, CopyPad)[i] MI_LMDMo_Terminate [i] MI_LI_Period MI_LI_MEPID MI_LI_CoS	
MT diagnostic trail termination sink function for MEP (MTDe_TT_Sk)		
	MI_GAL_Enable MI_CV_OAM_Tool MI_1TH_OAM_Tool MI_1TH_Start MI_1TH_Terminate MI_LMo_OAM_Tool MI_DMo_OAM_Tool MI_1DMo_OAM_Tool MI_1DMo_Start(Test_ID)[i] MI_1DMo_Terminate[i] MI_SLo_OAM_Tool MI_DP_Loopback_Enable	
G.8121.1 specific	MI_MEP_ID MI_1TH_Start(Period)	
G.8121.2 specific	MI_FEC_Checking PM_Responder_Enable	
MT diagnostic trail termination source function for MIP (MTDi_TT_So)		

Table II-4 – MI groupings of the MT diagnostic functions

Symbol	Management information	Managed object class
	MI_GAL_Enable MI_TTLVALUE MI_MIP_ID MI_CV_OAM_Tool MI_DP_Loopback_Enable	
G.8121.2 specific	MI_Target_FEC MI_Ifnun MI_MTU	
MT diagnostic trail termination sink function for MIP (MTDi_TT_Sk)		
	MI_GAL_Enable MI_MIP_ID MI_CV_OAM_Tool MI_DP_Loopback_Enable	
G.8121.2 specific	MI_FEC_Checking	

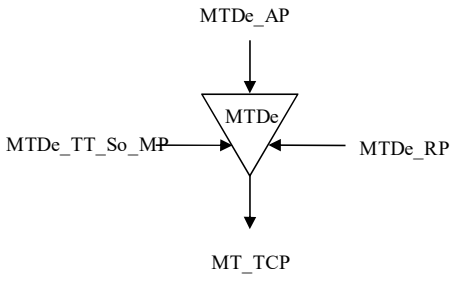
II.5 MPLS-TP to non-MPLS-TP client adaptation functions

Table II-5 – MI groupings of the MPLS-TP to non-MPLS-TP client adaptation functions

Symbol	Management information (blue: client layer related red: server layer related)	Managed object class
MPLS-TP to non-MPLS-TP client adaptation source functions		
	MI_AdminState MI_FCSEnable MI_CWEnable MI_SQUse MI_PRI2PSCMapping MI_MEP_MAC* MI_Client_MEL* MI_LCK_Period* MI_LCK_Pri* MI_MEL* * ETH OAM related	

Table II-5 – MI groupings of the MPLS-TP to non-MPLS-TP client adaptation functions

Symbol	Management information (blue: client layer related red: server layer related)	Managed object class
	<p>MI_Active MI_ECC_CoS MI_GAL_Enable</p>	
	<p>MI_Active MI_ECC_CoS MI_GAL_Enable</p>	
<p>MPLS-TP to non-MPLS-TP client adaptation sink functions</p>		
	<p>MI_Admin_State MI_LCK_Period * MI_LCK_Pri * MI_Client_MEL * MI_MEP_MAC * MI_AIS_Pri * MI_AIS_Period * MI_MEL MI_FCSEnable MI_CWEnable MI_SQUse MI_GAL_Enable MI_CoS2PRIMapping * ETH OAM related</p>	
	<p>MI_Active MI_GAL_Enable</p>	

Table II-5 – MI groupings of the MPLS-TP to non-MPLS-TP client adaptation functions

Symbol	Management information (blue: client layer related red: server layer related)	Managed object class
 <p>The diagram shows a yellow trapezoidal symbol labeled 'MT/MCC'. An arrow labeled 'MT/MCC_A_SK_MP' points to the left side of the symbol. An arrow labeled 'MT_AP' points to the bottom of the symbol. Three arrows point upwards from the top of the symbol to the labels 'IP v4 FWP', 'IP v6 FWP', and 'OSI FWP'. A bracket above these three labels is labeled 'MCC_FP'.</p>	<p>MI_Active MI_GAL_Enable</p>	

II.6 Non-MPLS-TP server to MPLS-TP adaptation functions

Table II-6 – MI groupings of the non-MPLS-TP server to MPLS-TP adaptation functions

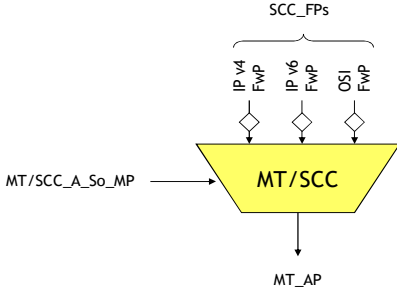
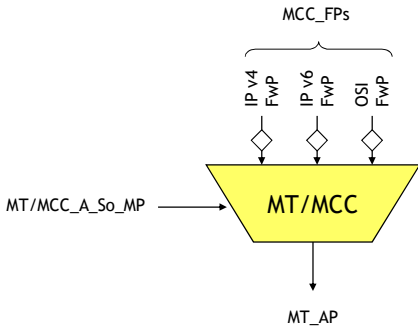
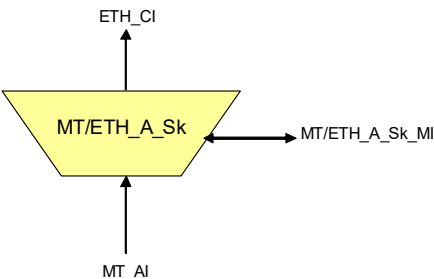
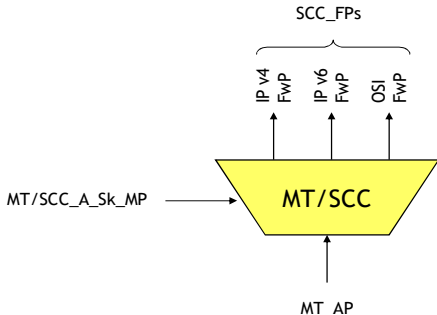
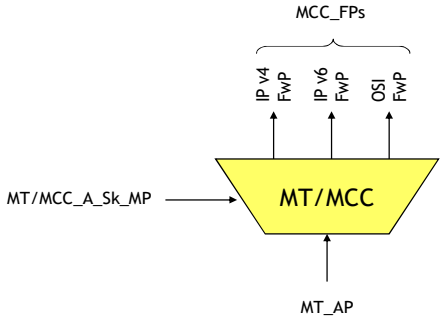
Symbol	Management information (blue: client layer related red: server layer related)	Managed object class
Non-MPLS-TP server to MPLS-TP adaptation source functions		
	<p>MI_Active</p> <p>MI_SCCType (not in ETH/MT)</p> <p>MI_Etype (only in ETH/MT)</p> <p>MI_Label[1...M]</p> <p>MI_LSPTType[1...M]</p> <p>MI_CoS[1...M]</p> <p>MI_PHB2TCMapping[1...M]</p> <p>MI_QoSEncodingMode[1...M]</p> <p>MI_Mode[1...M]</p> <p>MI_GAL_Enable[1...M]</p> <p>Only in ODUkP-h/MT:</p> <p>MI_INCREASE</p> <p>MI_DECREASE</p> <p>MI_TSNUM</p> <p>MI_ODUflexRate</p>	

Table II-6 – MI groupings of the non-MPLS-TP server to MPLS-TP adaptation functions

Symbol	Management information (blue: client layer related red: server layer related)	Managed object class
Non-MPLS-TP server to MPLS-TP adaptation sink functions		
	<p>MI_Active MI_SCCType (not in ETH/MT) MI_Etype (only in ETH/MT) MI_Frame_Type_Config (only in ETH/MT) MI_Label[1...M] MI_LSPTType[1...M] MI_CoS[1...M] MI_TC2PHBMapping[1...M] MI_QoSDecodingMode[1...M] MI_Mode MI_LCK_Period[1...M] MI_LCK_CoS[1...M] MI_Admin_State MI_AIS_Period[1...M] MI_AIS_CoS[1...M] MI_GAL_Enable[1...M] MI_LCK_OAM_Tool [1...M] MI_AIS_OAM_Tool[1...M] Only in ODUkP-h/MT: MI_INCREASE MI_DECREASE MI_AcSL MI_AcEXI MI_LastInvalidUPI MI_cPLM MI_cLFD MI_cEXM MI_cUPM (not ETH/MT)</p>	
G.8121.2 specific	MI_Local_Defect[i]	

Based on the groupings above the following packages have been identified.

Table II-7 – Derived MI groupings of the MPLS-TP functions

MI groupings	Package/Object class name
TTP MI source grouping	
MI_Active	
MI_INCREASE MI_DECREASE MI_TSNUM MI_ODUflexRate	HaoCapableTtpSource_Pac
TTP MI sink grouping	
MI_Active	
MI_Frame_Type_Config	EthServerTtpSink_Pac
MI_INCREASE MI_DECREASE	HaoCapableTtpSink_Pac
TTP MI grouping	
MI_SCCType	GfpMapping_Pac
MI_Etype	EthServerTtp_Pac
MT_CTP MI source grouping	
MI_PHB2TCMapping[1...M] MI_QoSEncodingMode[1...M] MI_APS_OAM_CoS[1...M]	MT_ConnectionTerminationPointSource
MT_CTP MI sink grouping	
MI_TC2PHBMapping[1...M] MI_QoSDecodingMode[1...M] MI_LCK_Period[1...M] MI_LCK_CoS[1...M] MI_Admin_State MI_AIS_Period[1...M] MI_AIS_CoS[1...M] MI_LCK_OAM_Tool [1...M] MI_AIS_OAM_Tool[1...M]	MT_ConnectionTerminationPointSink
MT_CTP MI grouping	
MI_Label[1...M] MI_LSPTType[1...M] MI_CoS[1...M] MI_Mode[1...M] MI_GAL_Enable[1...M] MI_APS_OAM_Tool[1...M]	MT_ConnectionTerminationPoint

Appendix III

UML model data dictionary

(This appendix does not form an integral part of this Recommendation.)

The data dictionary contains, in MS Word document format, the details of the MPLS-TP NE management-protocol-neutral information model, including the description and properties of the object classes and their attributes and operations. These details information are generated automatically by a Gendoc tool from the UML model.

The ITU-T G.8152 data dictionary is provided in the G.8152_v2.00_DD.zip file at the repository website mentioned in clause 8 above.

Bibliography

- [b-Eclipse-Papyrus] Papyrus Eclipse UML Modelling Tool
<https://www.eclipse.org/papyrus/>
- [b-ONF TR-515] ONF TR-515_Papyrus-Guidelines.docx
https://www.opennetworking.org/wp-content/uploads/2018/08/TR-515_Papyrus_Guidelines_v1.3-1-1.pdf

ITU-T Y-SERIES RECOMMENDATIONS

GLOBAL INFORMATION INFRASTRUCTURE, INTERNET PROTOCOL ASPECTS, NEXT-GENERATION NETWORKS, INTERNET OF THINGS AND SMART CITIES

GLOBAL INFORMATION INFRASTRUCTURE	
General	Y.100–Y.199
Services, applications and middleware	Y.200–Y.299
Network aspects	Y.300–Y.399
Interfaces and protocols	Y.400–Y.499
Numbering, addressing and naming	Y.500–Y.599
Operation, administration and maintenance	Y.600–Y.699
Security	Y.700–Y.799
Performances	Y.800–Y.899
INTERNET PROTOCOL ASPECTS	
General	Y.1000–Y.1099
Services and applications	Y.1100–Y.1199
Architecture, access, network capabilities and resource management	Y.1200–Y.1299
Transport	Y.1300–Y.1399
Interworking	Y.1400–Y.1499
Quality of service and network performance	Y.1500–Y.1599
Signalling	Y.1600–Y.1699
Operation, administration and maintenance	Y.1700–Y.1799
Charging	Y.1800–Y.1899
IPTV over NGN	Y.1900–Y.1999
NEXT GENERATION NETWORKS	
Frameworks and functional architecture models	Y.2000–Y.2099
Quality of Service and performance	Y.2100–Y.2199
Service aspects: Service capabilities and service architecture	Y.2200–Y.2249
Service aspects: Interoperability of services and networks in NGN	Y.2250–Y.2299
Enhancements to NGN	Y.2300–Y.2399
Network management	Y.2400–Y.2499
Network control architectures and protocols	Y.2500–Y.2599
Packet-based Networks	Y.2600–Y.2699
Security	Y.2700–Y.2799
Generalized mobility	Y.2800–Y.2899
Carrier grade open environment	Y.2900–Y.2999
FUTURE NETWORKS	Y.3000–Y.3499
CLOUD COMPUTING	Y.3500–Y.3999
INTERNET OF THINGS AND SMART CITIES AND COMMUNITIES	
General	Y.4000–Y.4049
Definitions and terminologies	Y.4050–Y.4099
Requirements and use cases	Y.4100–Y.4249
Infrastructure, connectivity and networks	Y.4250–Y.4399
Frameworks, architectures and protocols	Y.4400–Y.4549
Services, applications, computation and data processing	Y.4550–Y.4699
Management, control and performance	Y.4700–Y.4799
Identification and security	Y.4800–Y.4899
Evaluation and assessment	Y.4900–Y.4999

For further details, please refer to the list of ITU-T Recommendations.

SERIES OF ITU-T RECOMMENDATIONS

- Series A Organization of the work of ITU-T
- Series D Tariff and accounting principles and international telecommunication/ICT economic and policy issues
- Series E Overall network operation, telephone service, service operation and human factors
- Series F Non-telephone telecommunication services
- Series G Transmission systems and media, digital systems and networks**
- Series H Audiovisual and multimedia systems
- Series I Integrated services digital network
- Series J Cable networks and transmission of television, sound programme and other multimedia signals
- Series K Protection against interference
- Series L Environment and ICTs, climate change, e-waste, energy efficiency; construction, installation and protection of cables and other elements of outside plant
- Series M Telecommunication management, including TMN and network maintenance
- Series N Maintenance: international sound programme and television transmission circuits
- Series O Specifications of measuring equipment
- Series P Telephone transmission quality, telephone installations, local line networks
- Series Q Switching and signalling, and associated measurements and tests
- Series R Telegraph transmission
- Series S Telegraph services terminal equipment
- Series T Terminals for telematic services
- Series U Telegraph switching
- Series V Data communication over the telephone network
- Series X Data networks, open system communications and security
- Series Y Global information infrastructure, Internet protocol aspects, next-generation networks, Internet of Things and smart cities
- Series Z Languages and general software aspects for telecommunication systems