

Two Dimensional IP Routing Architecture

draft-xu-rtgwg-twod-ip-routing-00

**Mingwei Xu, Jianping Wu, Shu Yang
CERNET**

**Dan Wang
Hong Kong Polytechnic University**

IETF83 Meeting, Paris, March 2012

Traditional Routing

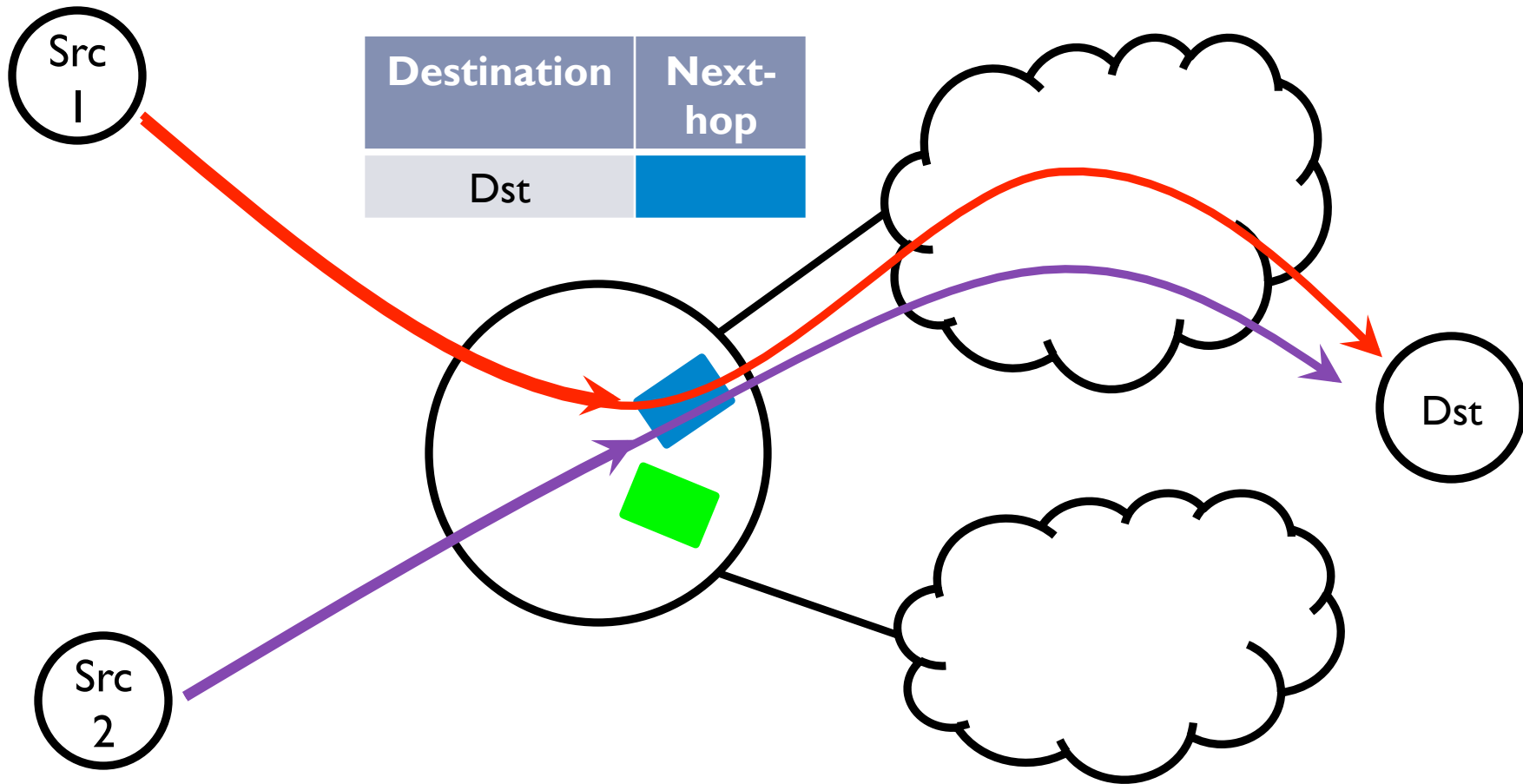

TwoD-IP Routing

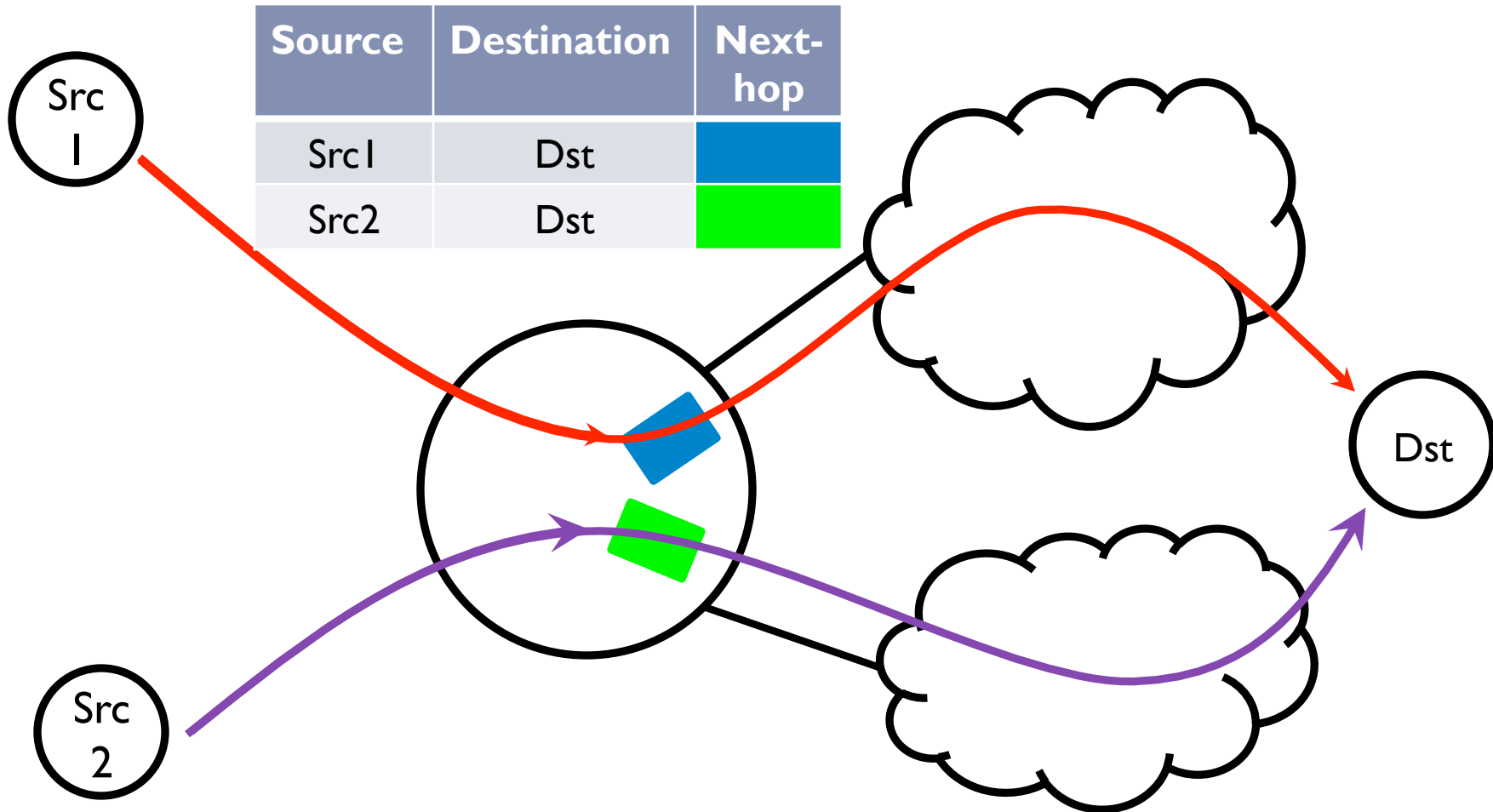

Add source address into the routing system

Related Work

- ▶ **Source Routing**

- ▶ Control handled by end hosts
- ▶ Face security problems

- ▶ **MPLS**

- ▶ Additional packet/protocol overhead
- ▶ Control overhead
 - ▶ The overhead increases with the number of LSPs
- ▶ Some ISPs desire a pure-IP network

- ▶ **Others**

- ▶ one-hop source routing, policy-based routing, user-specific routing (e.g., NIRA), multi-topology routing, SAVI



Use Cases 1: Load Balancing

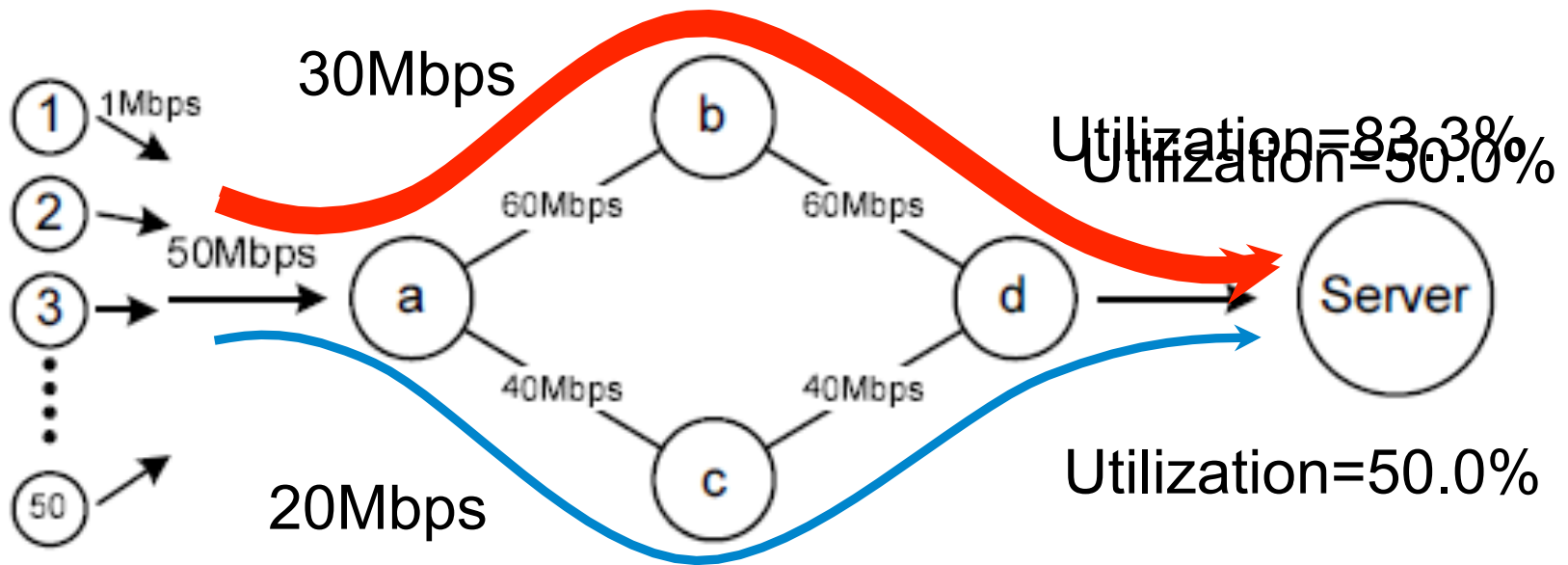

E.g., cloud computing

Use Cases2: Multi-homing

- ▶ Provider Independent address causes routing table inflation
- ▶ Provider Aggregatable address is recommended
- ▶ However:
 - ▶ Complicating configurations
 - ▶ Facing failure
 - ▶ Ingress filtering presents additional difficulties

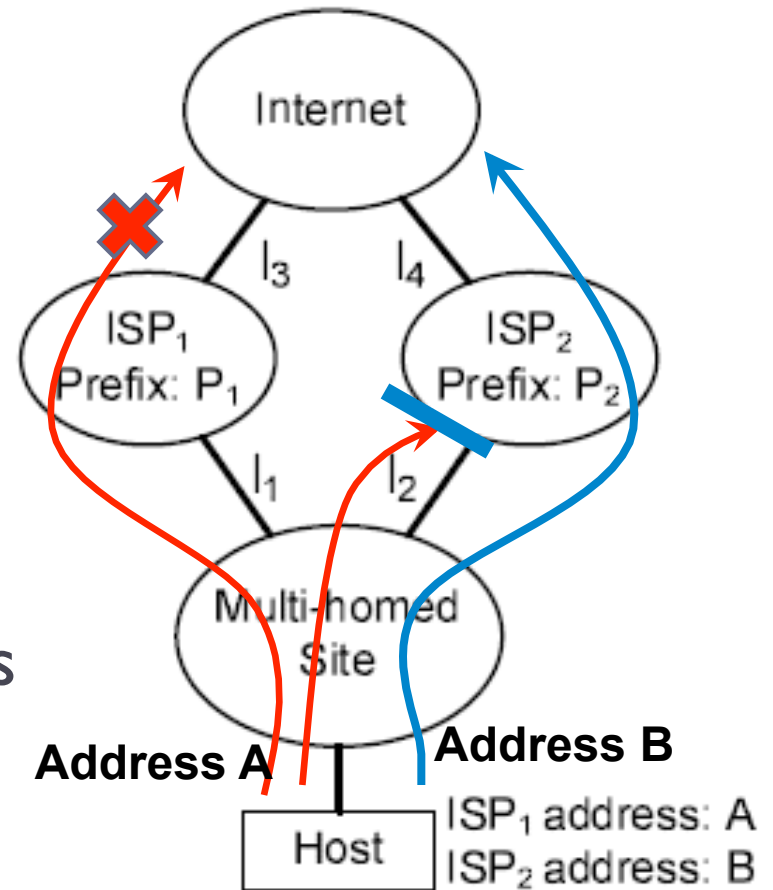

Use Cases3: Diagnosis & Measurement

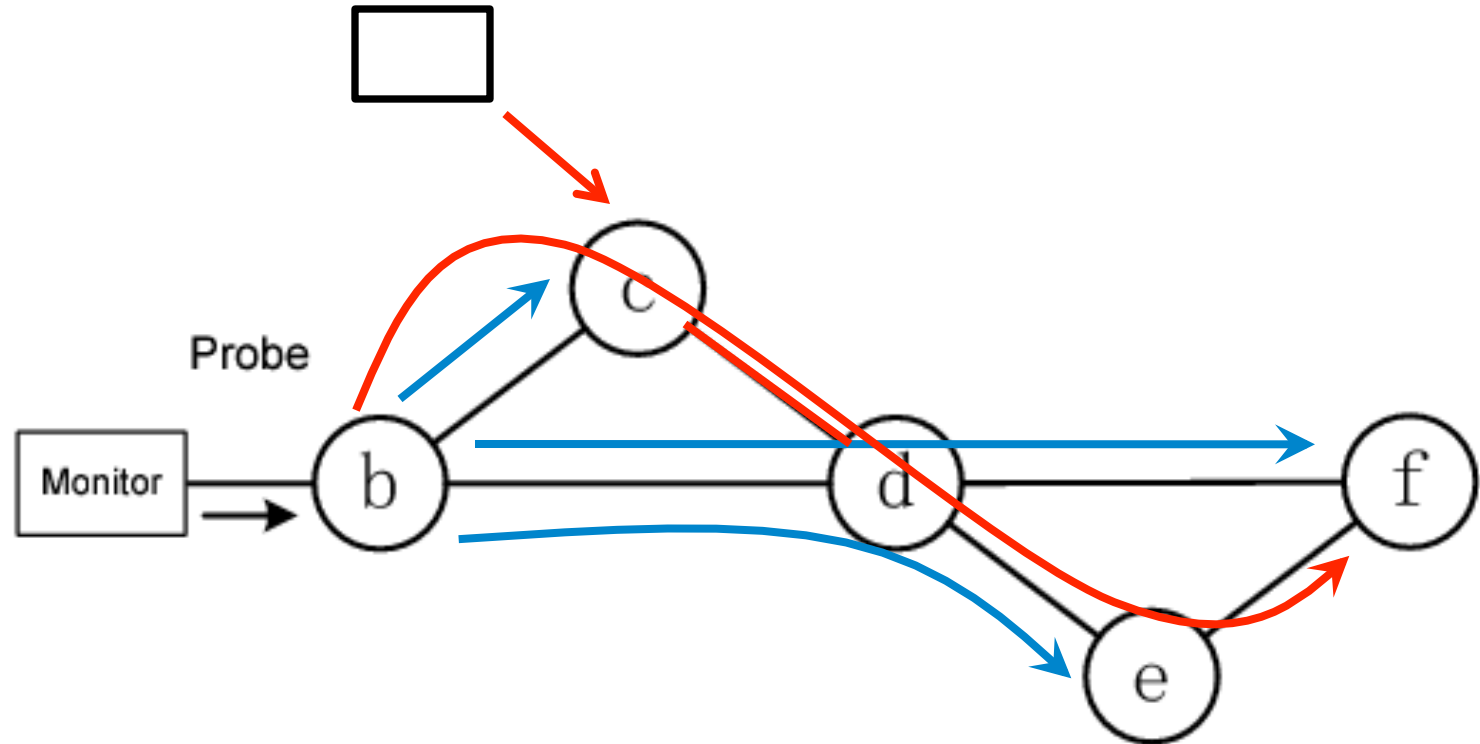

- ▶ Reduce probing traffic
 - ▶ Reduce number of monitors (e.g., link (c, d))
-



TwoD-IP Routing Framework

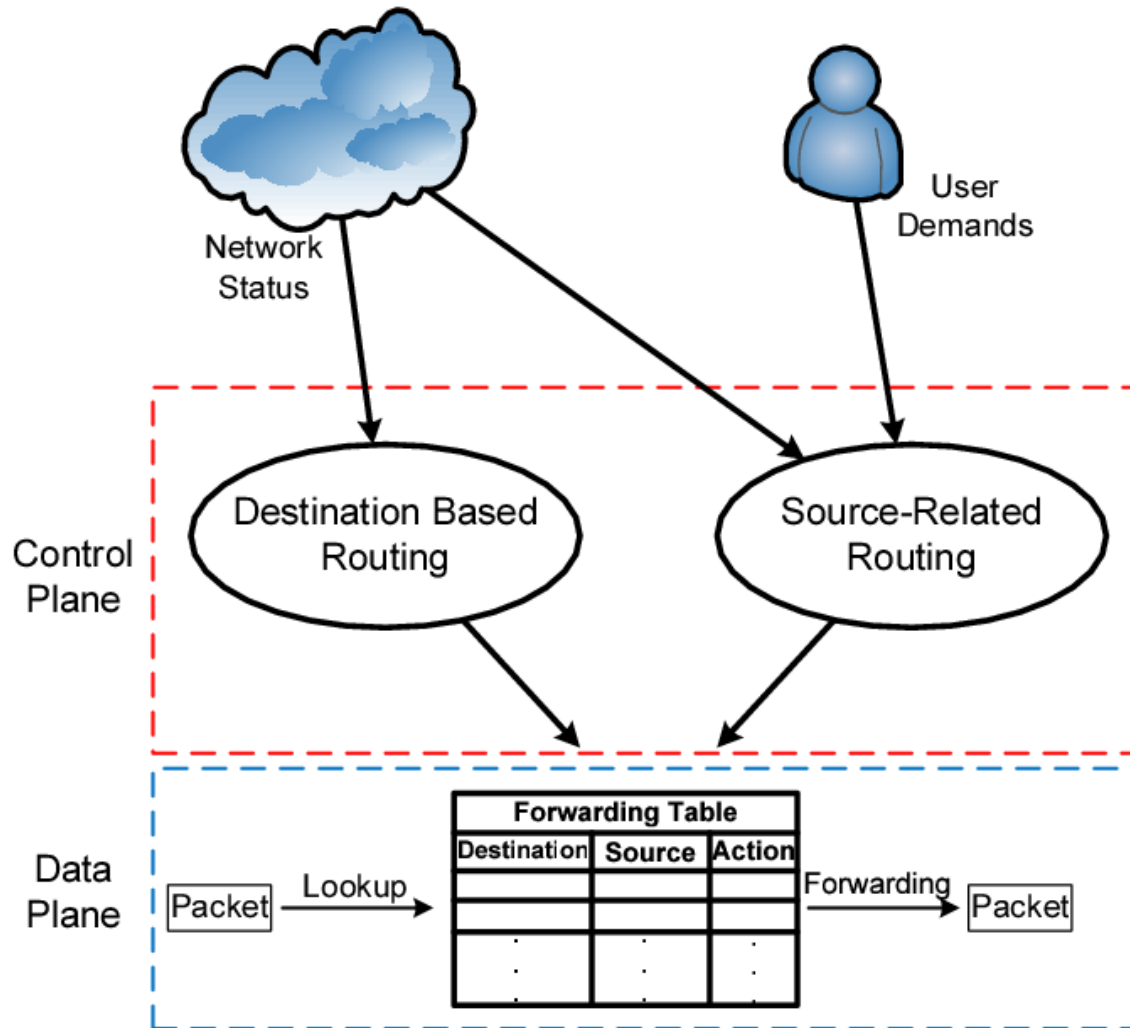

Challenges

- ▶ **Forwarding table design**

- ▶ Table size: avoid explosion
- ▶ Lookup speed

Source	Destination	Next-hop

- ▶ **New source-related routing design**

- ▶ **Efficient**

- ▶ Minimum states on routers and minimum exchanged messages

Worst Case: N^2

- ▶ **Consistent**

- ▶ Avoid loops and policy confliction



FIB Structure for TwoD-IP(FIST)

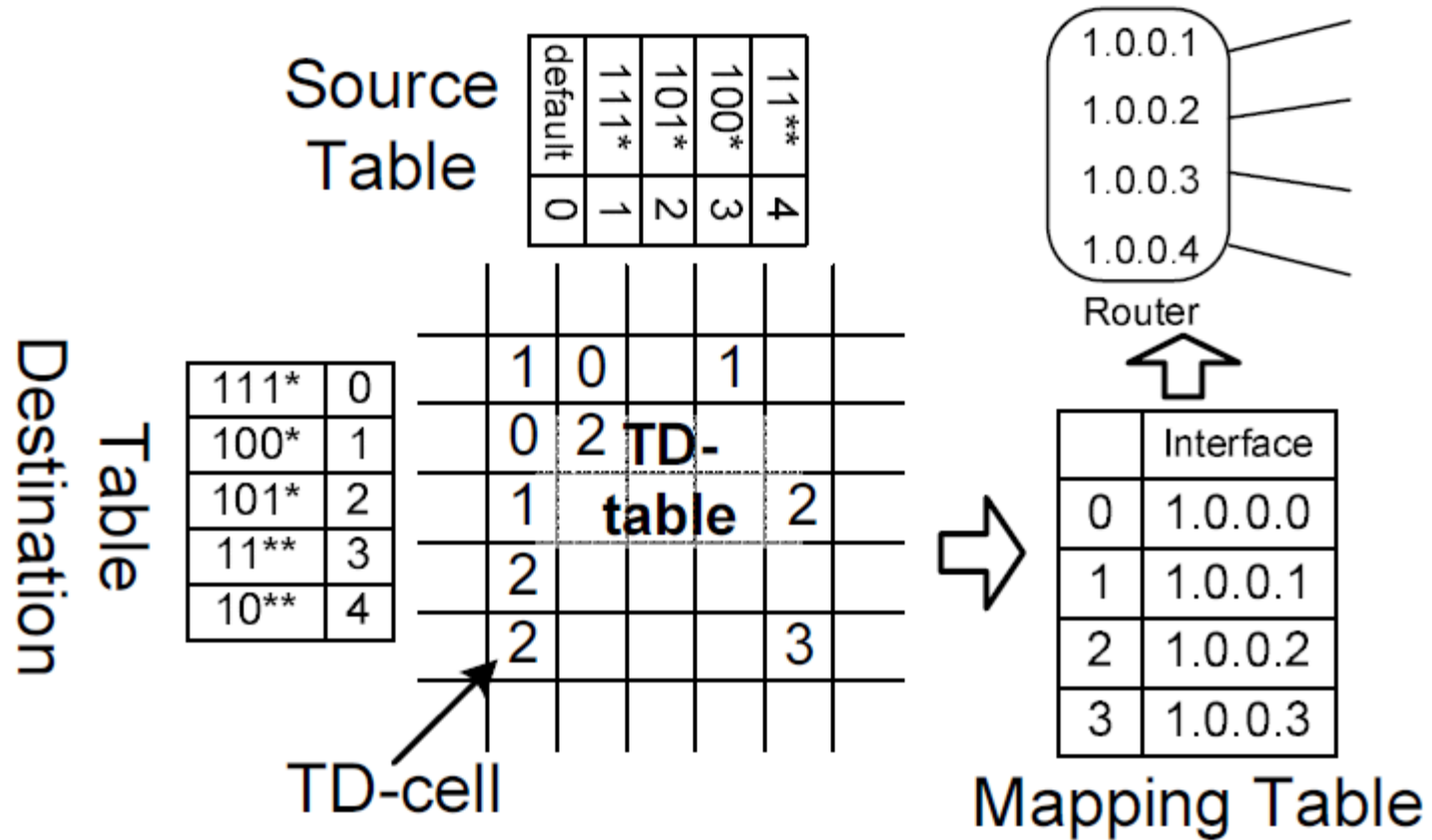

Lookup Action

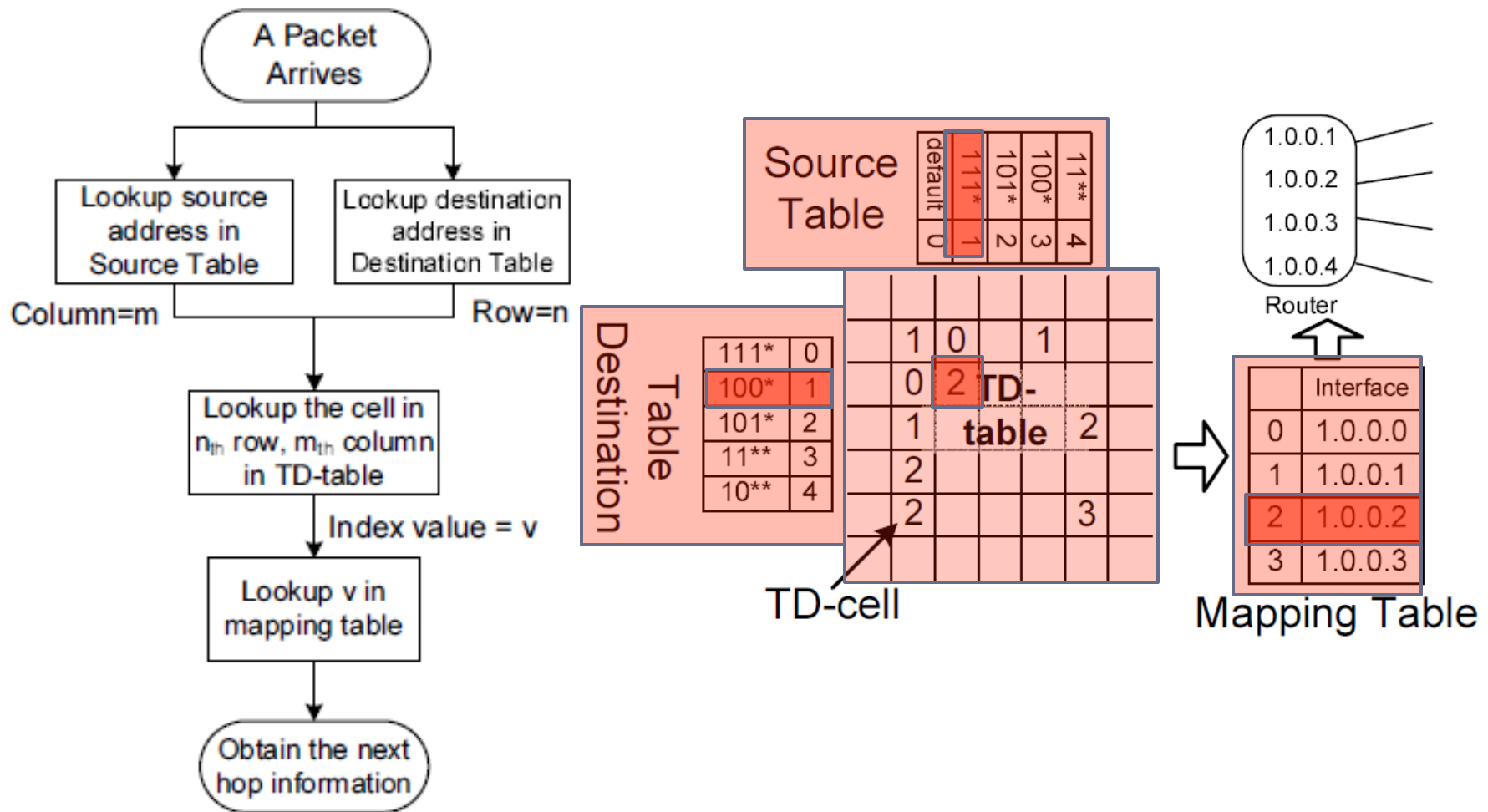

Implementation Status

- ▶ We have implemented the TwoD-IP FIB on a hardware router with GE interfaces, which can achieve line speed
- ▶ We are designing routing protocols based on TwoD-IP Routing



Discussion in the mailing list

- ▶ Most routers can already be programmed to support multi-path/ECMP/TE...
 - ▶ There are many patch-like solutions
 - ▶ TwoD-IP Routing intrinsically supports multi-path and can easily support load balancing, multi-homing...
- ▶ Adding source address can not solve anything
 - ▶ We list some possible beneficial cases
 - ▶ TwoD-IP Routing provides a pure IP routing platform to design new routing functions and protocols
- ▶ The FIB structure is interesting and valuable, but it is not much applicable within an IETF draft
 - ▶ It is described just for completion. We may abstract this part



Summary

- ▶ Source address is included in every packet, but is used rarely
- ▶ TwoD-IP Routing intrinsically supports multi-path and can easily support load balancing, multi-homing...
- ▶ TwoD-IP Routing provides a pure IP routing platform to design new routing functions and protocols
- ▶ Work in SAVI WG can guarantee source addresses are validated
- ▶ We have implemented the TwoD-IP Routing on a hardware router with FPGA, TCAM and SRAM
- ▶ We are planning to deploy several TwoD-IP routers in CERNET2 (a pure IPv6 backbone network)

