

ALTO Incremental Updates

draft-schwan-incr-updates-02

Nico Schwan
Bill Roome

<nico.schwan@alcatel-lucent.com>
<w.roome@alcatel-lucent.com>

Presented by Michael Scharf

IETF-84
Vancouver, Canada
2012-07-31

Updates in -02

- We assume HTTP+JSON as base protocol (ALTO Network & Cost Maps)
- Determine Map Version
 - Conclusion: Existing HTTP/1.1 mechanisms useful for conditional requests, but not for incremental updates
 - To be discussed: HTTP delta encoding [RFC 3229] as potential option
 - Proposal:
`(cost)-map-vtag plus update-interval`
- Incremental Update Options
 - New text: HTTP Byte range
 - Detailed specification of ALTO extension
- New section: Numerical evaluation
 - Cost Map size
 - JSON Patch vs. ALTO extension

Incremental Update

Request:

- New MIME Type: `"application/alto-update-param+json"`
- Input parameter: `{"reference-tag": "1266506140"}`

Response (options):

- JSON Patch (`draft-ietf-appsawg-json-patch-02`)
 - Supports "add", "remove", "replace", "move", "copy" or "test" operations
 - Example:

```
{ "replace": "meta/data/map/SRC-PID/DEST-PID", "value": 123 }
```

- ALTO Extension
 - Syntactically equal to Filtered Map services
 - Contains only changed values (or -1 for delete)
 - Example:

```
"SRC-PID": {"DEST-PID": 123}
```

Numerical Evaluation

Full Cost Map Size

np	cost-map size [bytes]
10	1,640
25	9,725
50	38,200
100	151,400
250	941,000
500	3,757,000
1000	15,014,000
2500	93,785,000
5000	375,070,000

- For less than 100 PIDs incr. updates are not needed
- For maps that require greater accuracy incr. updates are required

JSON Patch vs. ALTO Extension

np	JSON patch [bytes]	ALTO Cost Map message [bytes]
10	220	95
50	5,500	2,375
100	22,000	9,500
250	137,500	59,375
500	550,000	237,500
1000	2,200,000	950,000
2500	13,750,000	5,937,500
5000	55,000,000	23,750,000

- ALTO extension has a higher efficiency in terms of encoded bytes

np: Number of PIDS
Average length of PID names = 8 characters
Average number of digits in costs = 3 digits
Fraction of cost values changed = 5%

Numerical Evaluation

Note: When several destination costs change for the same source PID, the ALTO extension can be much more efficient than JSON Patch.

- JSON Patch

```
{ "replace": "meta/data/map/SRC-PID/DEST-1", "value": 123 }  
{ "replace": "meta/data/map/SRC-PID/DEST-2", "value": 321 }  
{ "replace": "meta/data/map/SRC-PID/DEST-3", "value": 456 }  
{ "replace": "meta/data/map/SRC-PID/DEST-4", "value": 654 }
```

- ALTO Extension

```
"SRC-PID": {"DEST-1": 123, "DEST-2": 321, "DEST-3": 456, "DEST-4": 654}
```

Architectural Considerations

- JSON Patch
 - Upcoming Standard
 - To be supported in libraries
- ALTO Extension
 - Syntactically equal to Filtered Maps

Architectural Considerations

- JSON Patch
 - Upcoming Standard
 - To be supported in libraries
- ALTO Extension
 - Syntactically equal to Filtered Maps

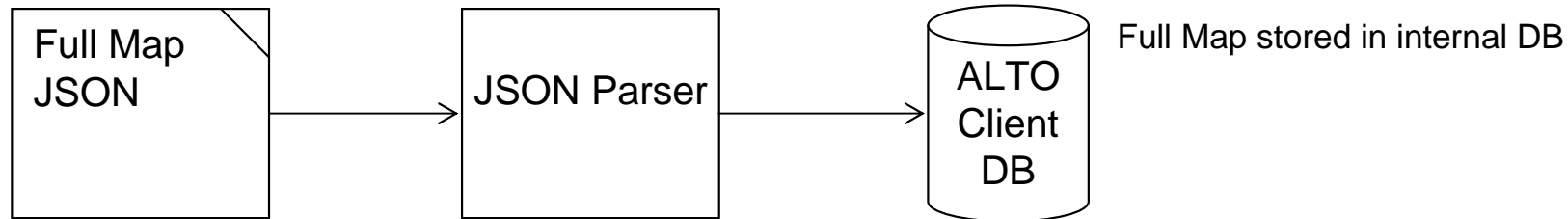

Incr. Update
JSON Patch

Incr. Update
ALTO Ext.

Architectural Considerations

- JSON Patch
 - Upcoming Standard
 - To be supported in libraries
- ALTO Extension
 - Syntactically equal to Filtered Maps

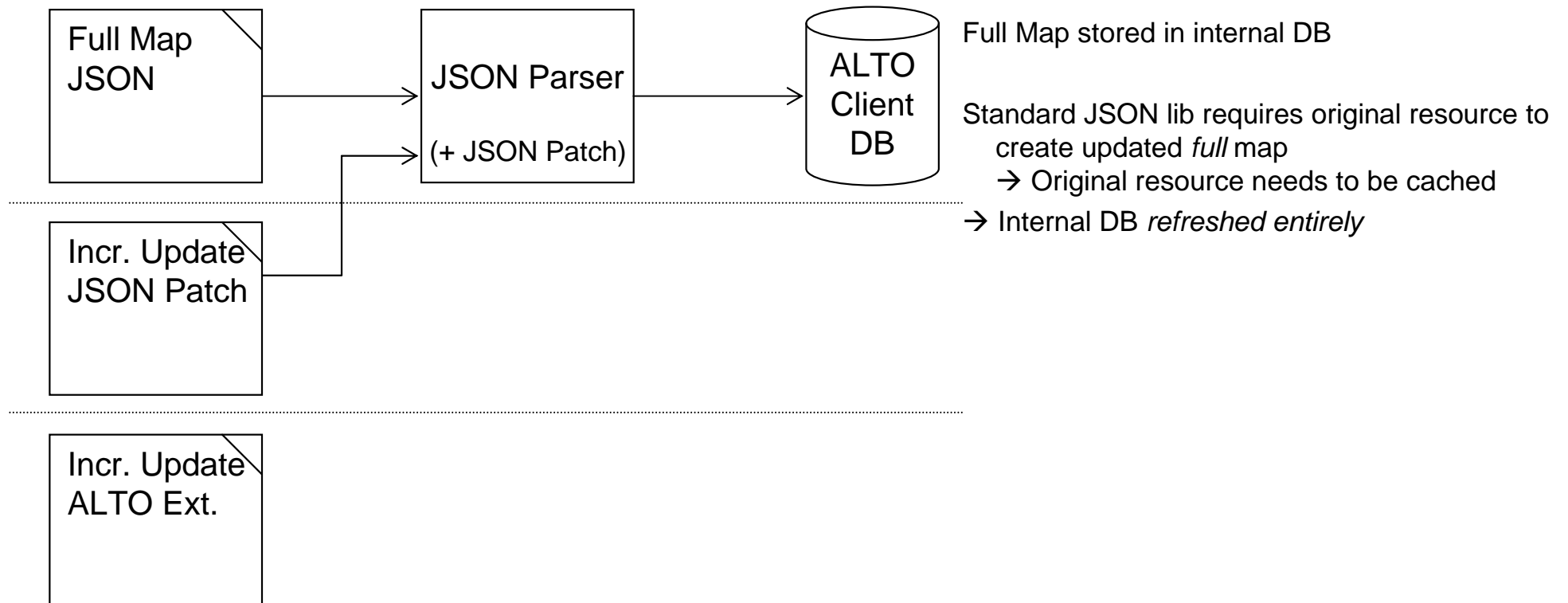

Architectural Considerations

- JSON Patch
 - Upcoming Standard
 - To be supported in libraries
- ALTO Extension
 - Syntactically equal to Filtered Maps

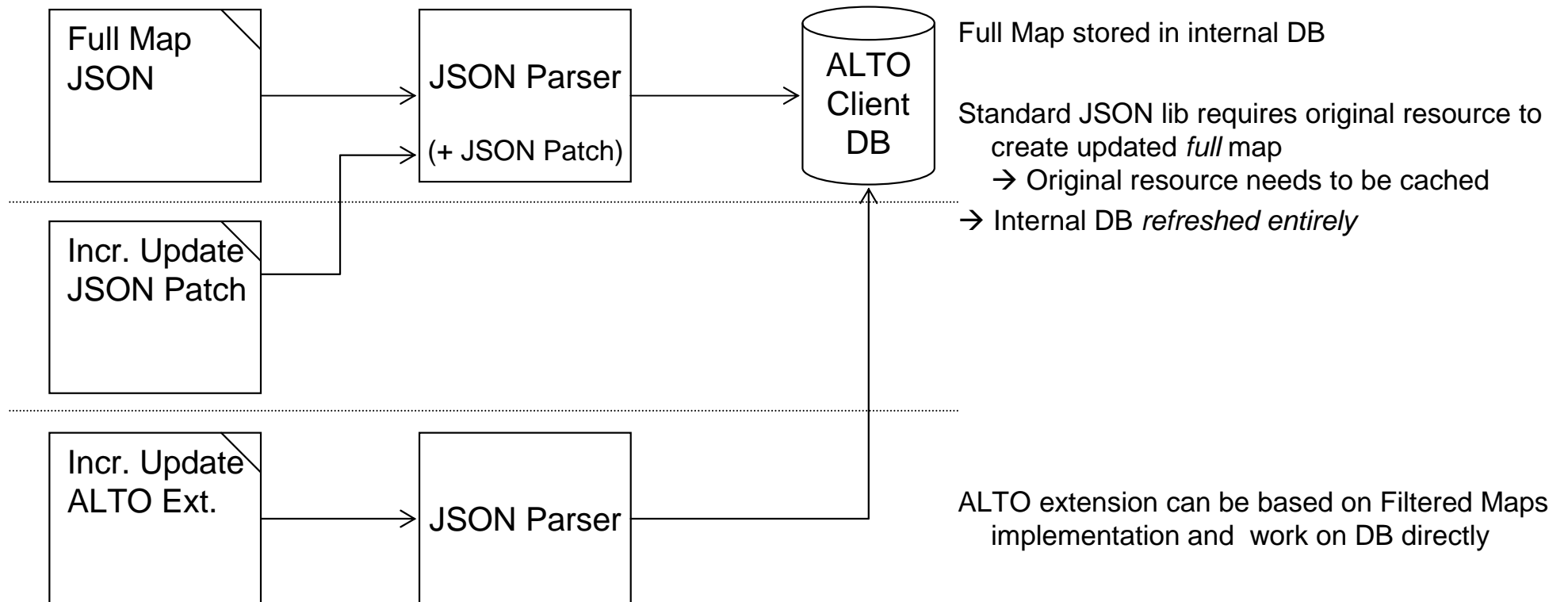

Architectural Considerations

- JSON Patch
 - Upcoming Standard
 - To be supported in libraries
- ALTO Extension
 - Syntactically equal to Filtered Maps

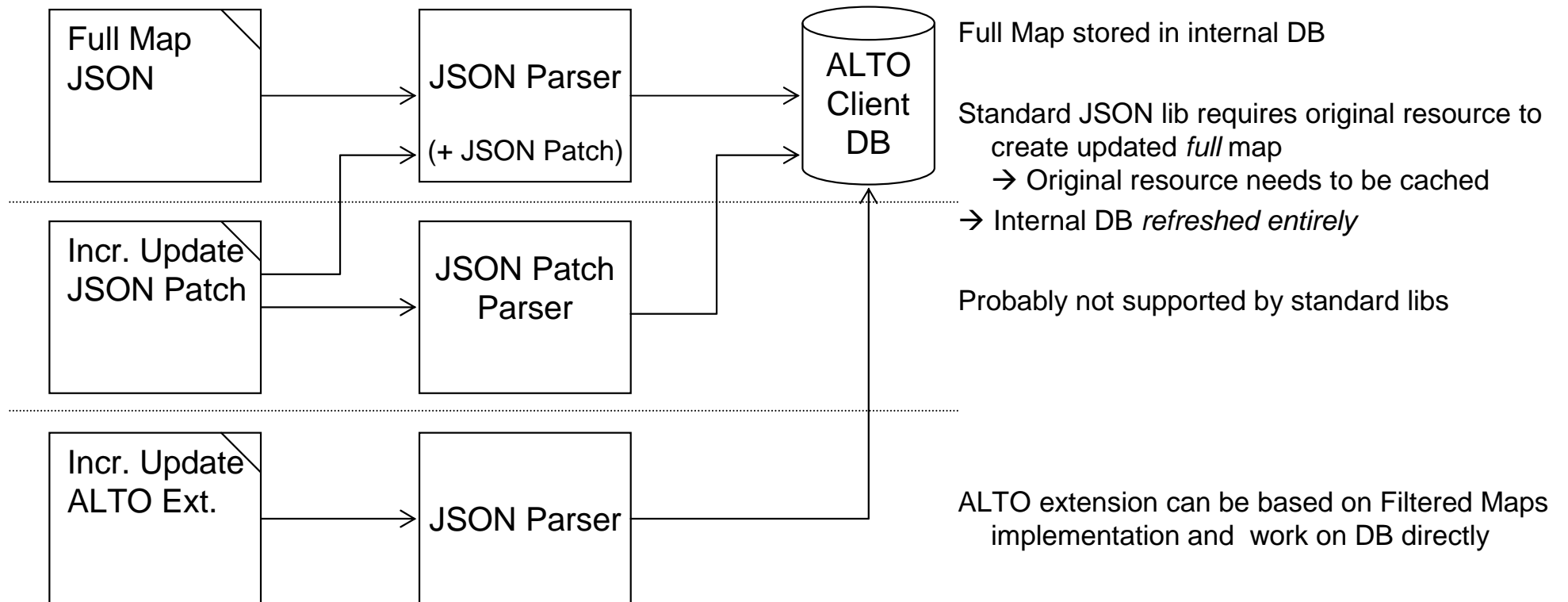

Summary

- Current draft identifies incremental update options
 - Determine Map Version
 - Incremental Update Options
 - Numerical evaluation
- JSON Patch vs. ALTO Extension
 - No clear winner
 - JSON Patch: Upcoming standard
 - ALTO Extension: Higher efficiency
- Opinions?