

Transitioning to MPTCP with efficient Protocol Converters

Gregory Detal <gregory.detal@uclouvain.be>
Christoph Paasch <christoph.paasch@uclouvain.be>

IP Networking Lab - UCLouvain



Need for Protocol Converters

- Transition to MPTCP will take several years
- Encourage early adopters by deploying protocol converters

Need for Protocol Converters

MPTCP Client

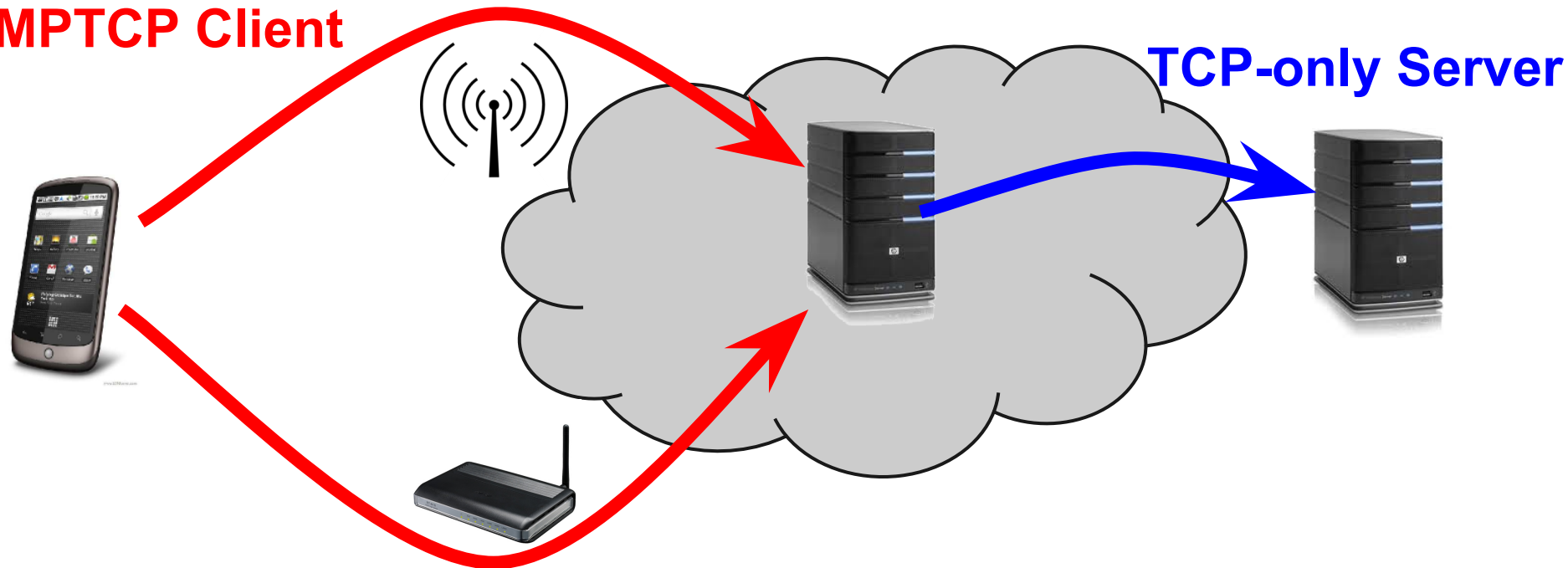

Our Design

- Translate MPTCP to TCP (or vice-versa)
- Supports multiple subflows

- Full In-Kernel implementation (3K LOC)
- High performance
 - Minimized allocations
 - Minimized data-copying

Our Design

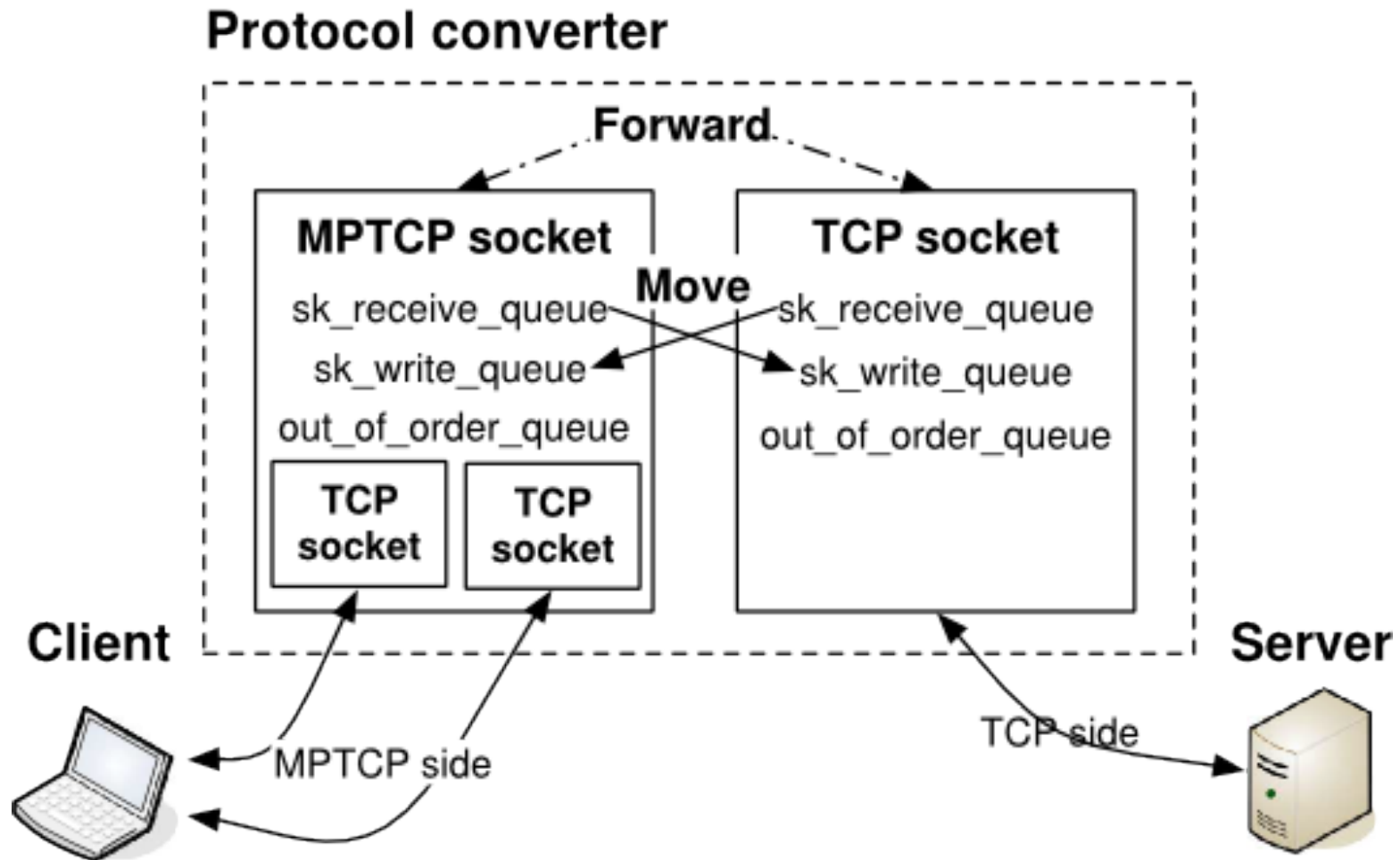

Performance evaluation



Protocol Converter vs. other solutions

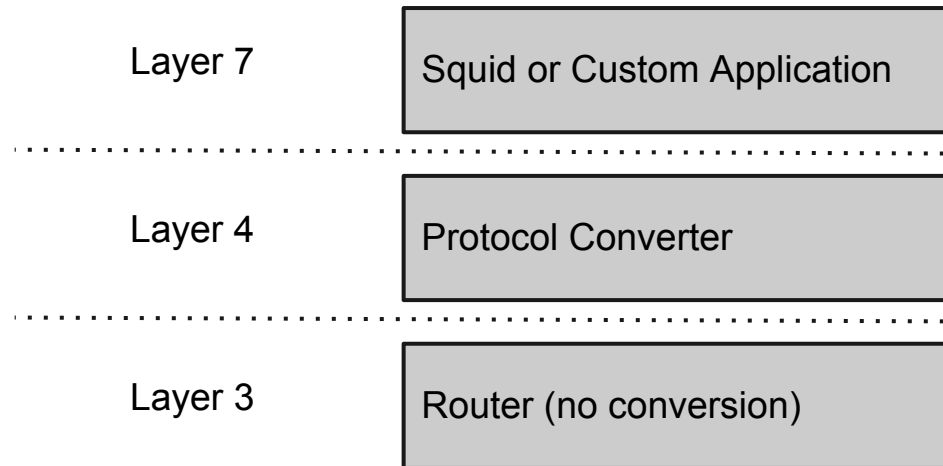

Apachebenchmark

- 100 parallel clients
- HTTP-get for files of varying size
- Up to 100000 Requests
- Measuring the number of requests per second

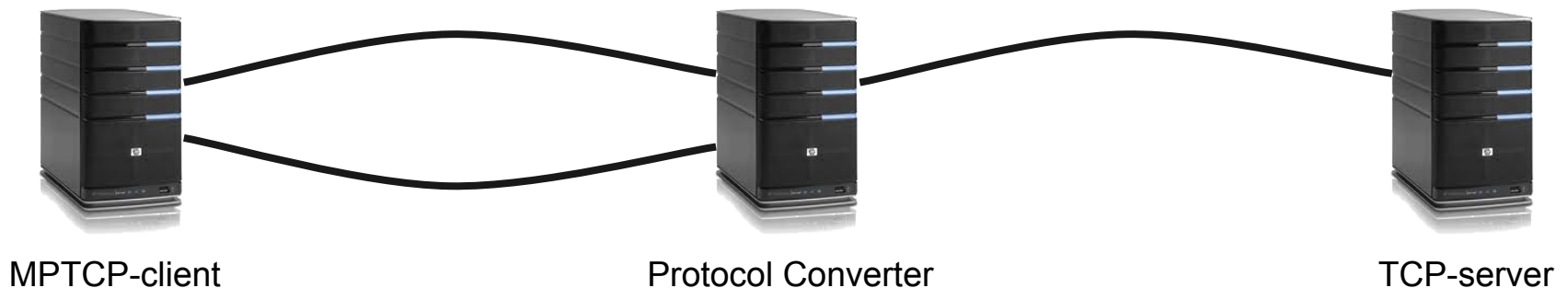

Apachebenchmark

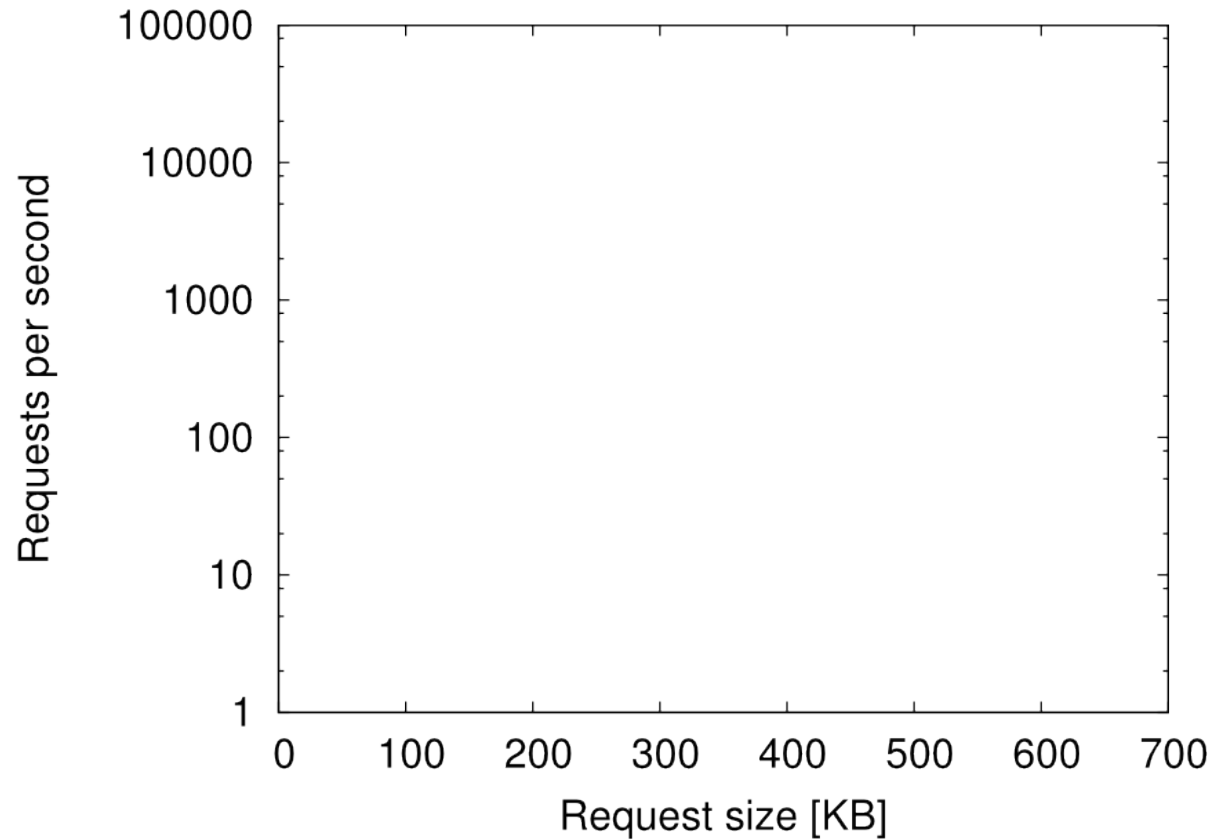

Apachebenchmark

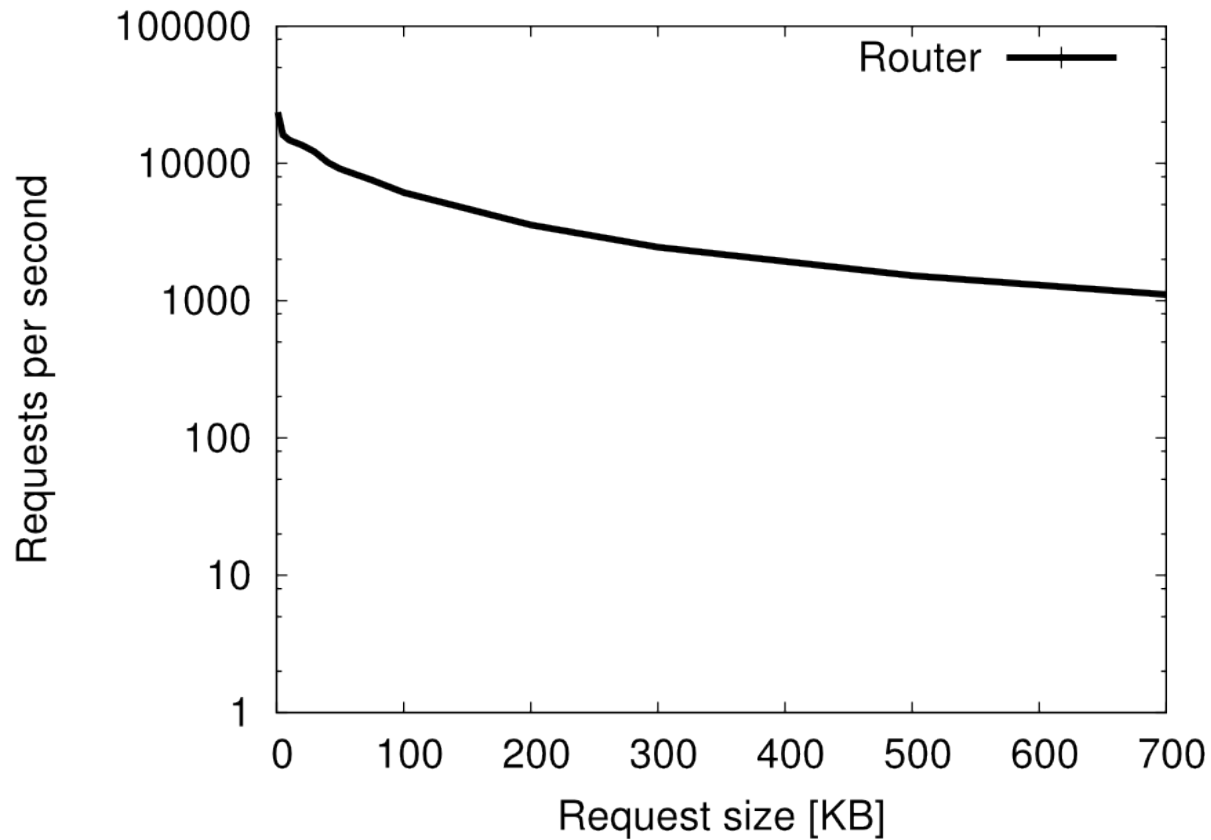

Apachebenchmark

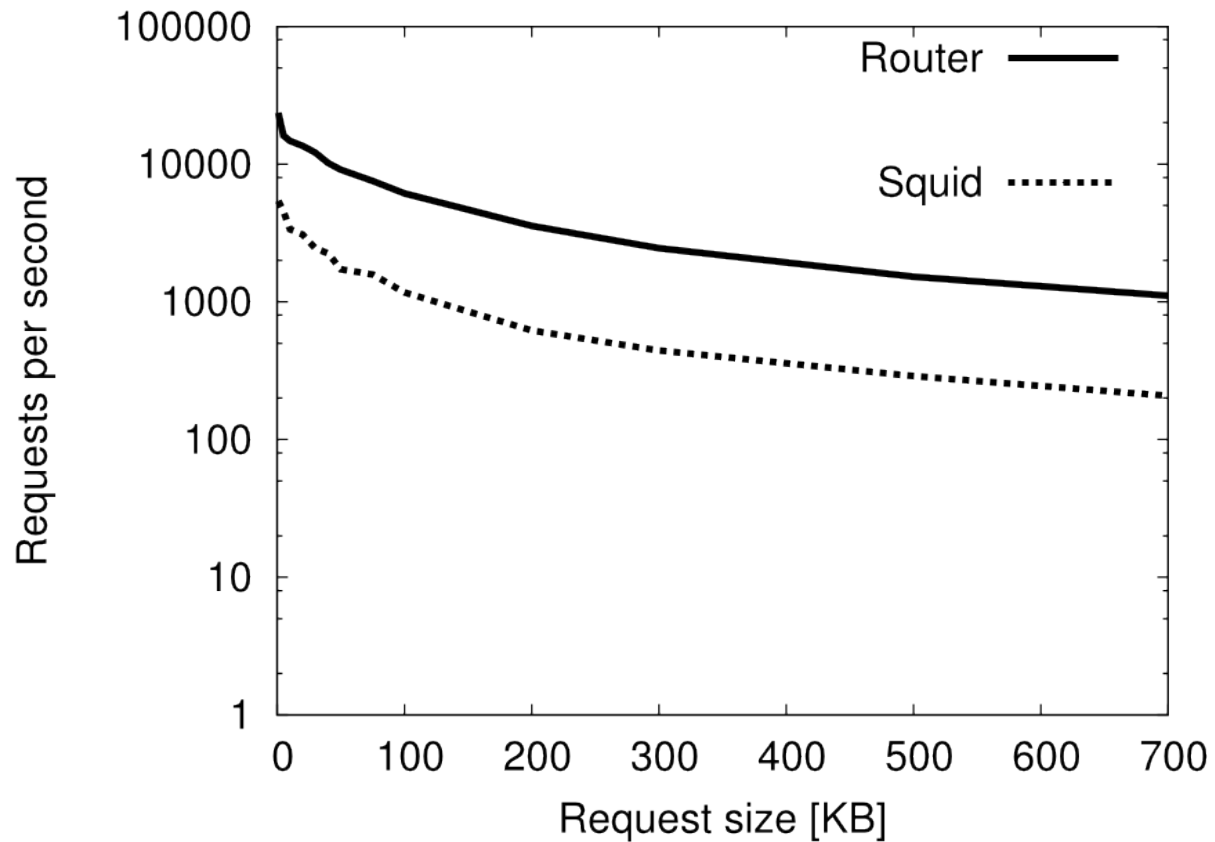

Apachebenchmark

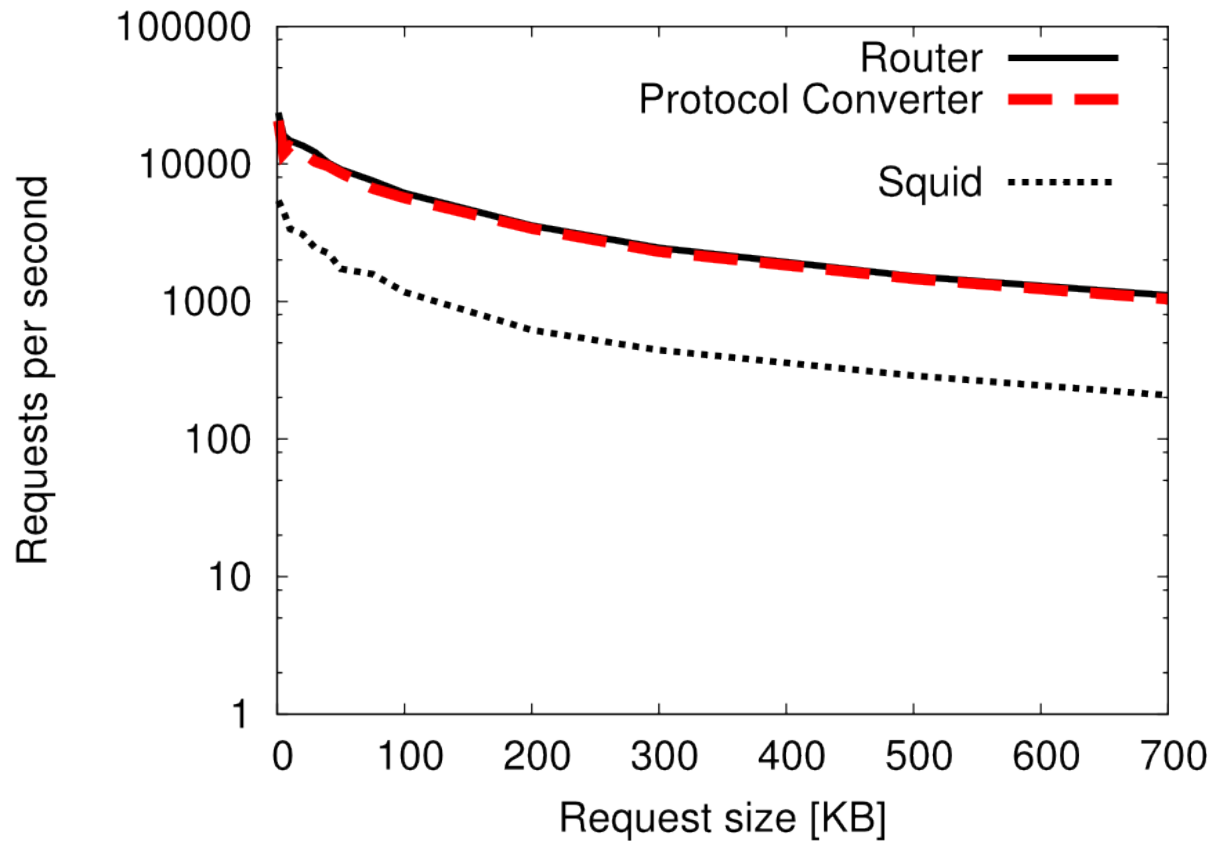

Forwarding at 10Gbps

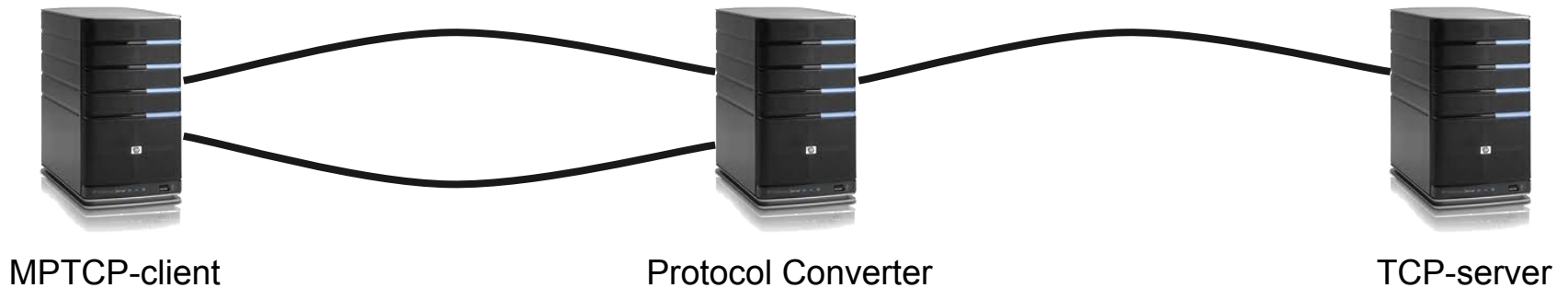

Forwarding at 10Gbps

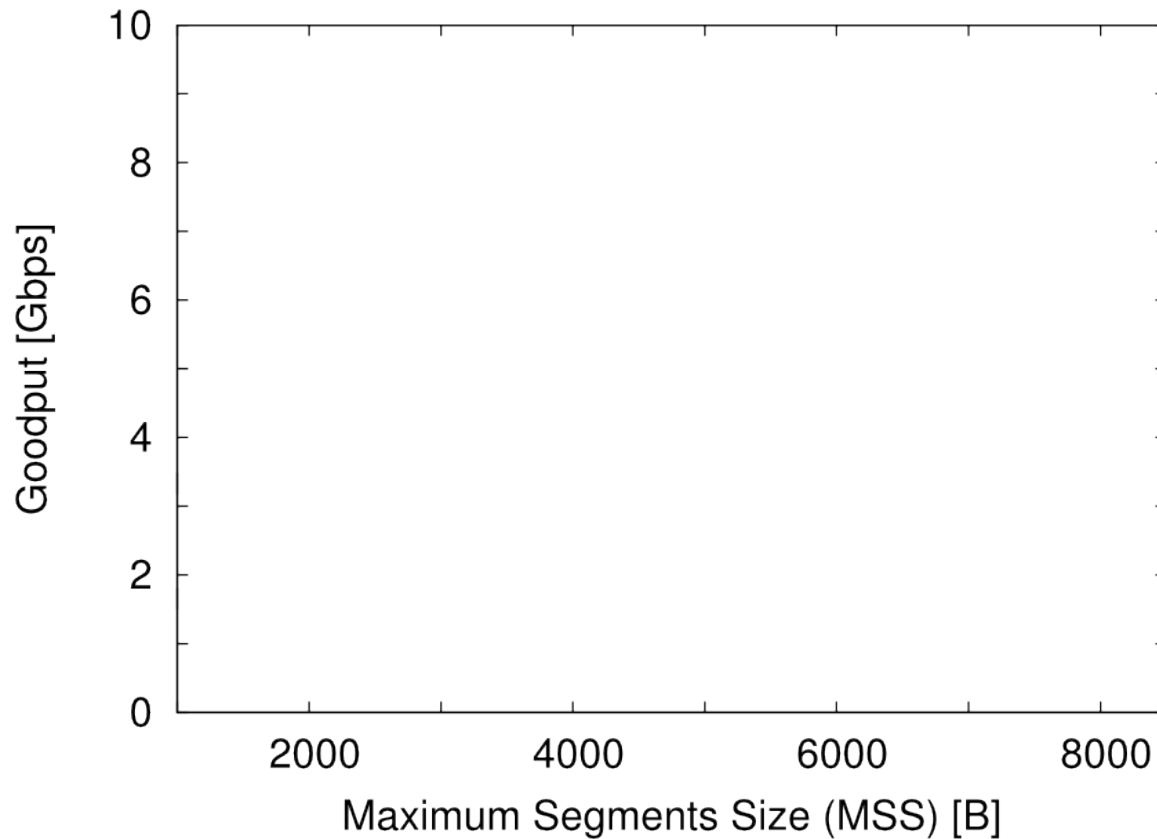

Forwarding at 10Gbps

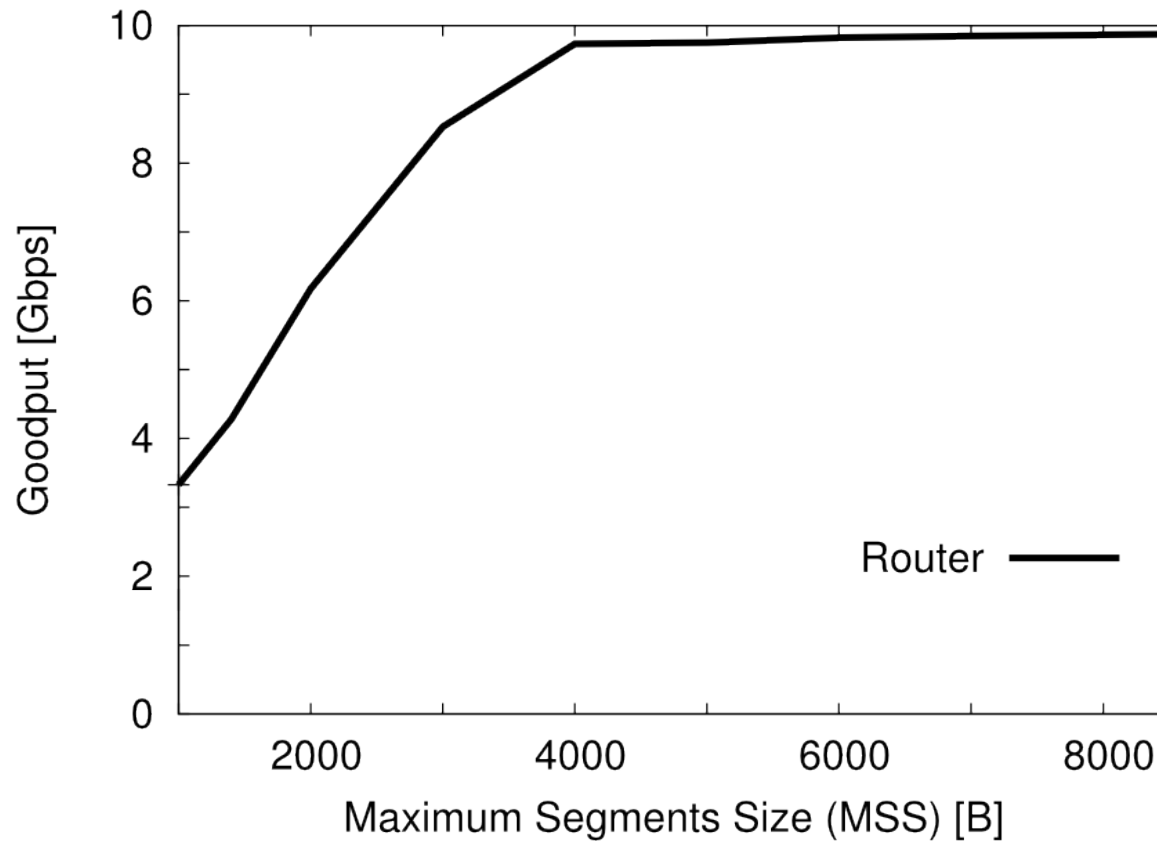

Forwarding at 10Gbps

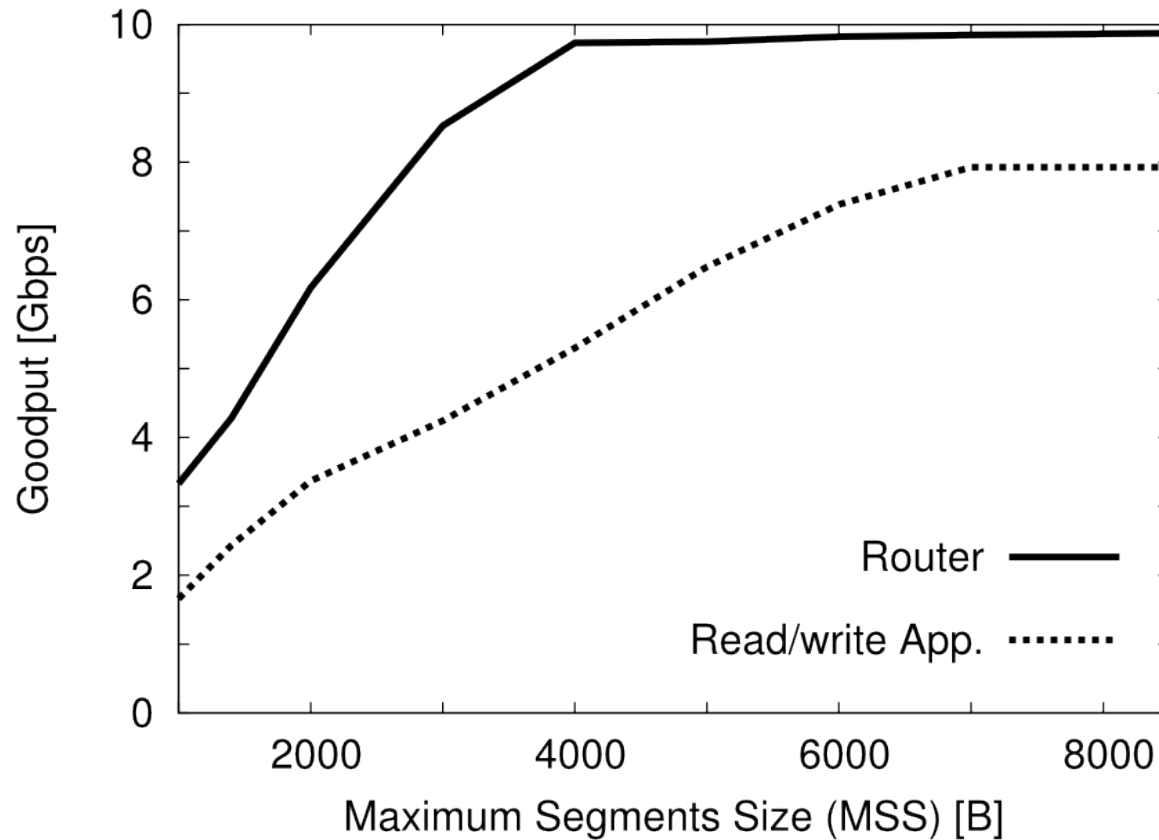

Forwarding at 10Gbps

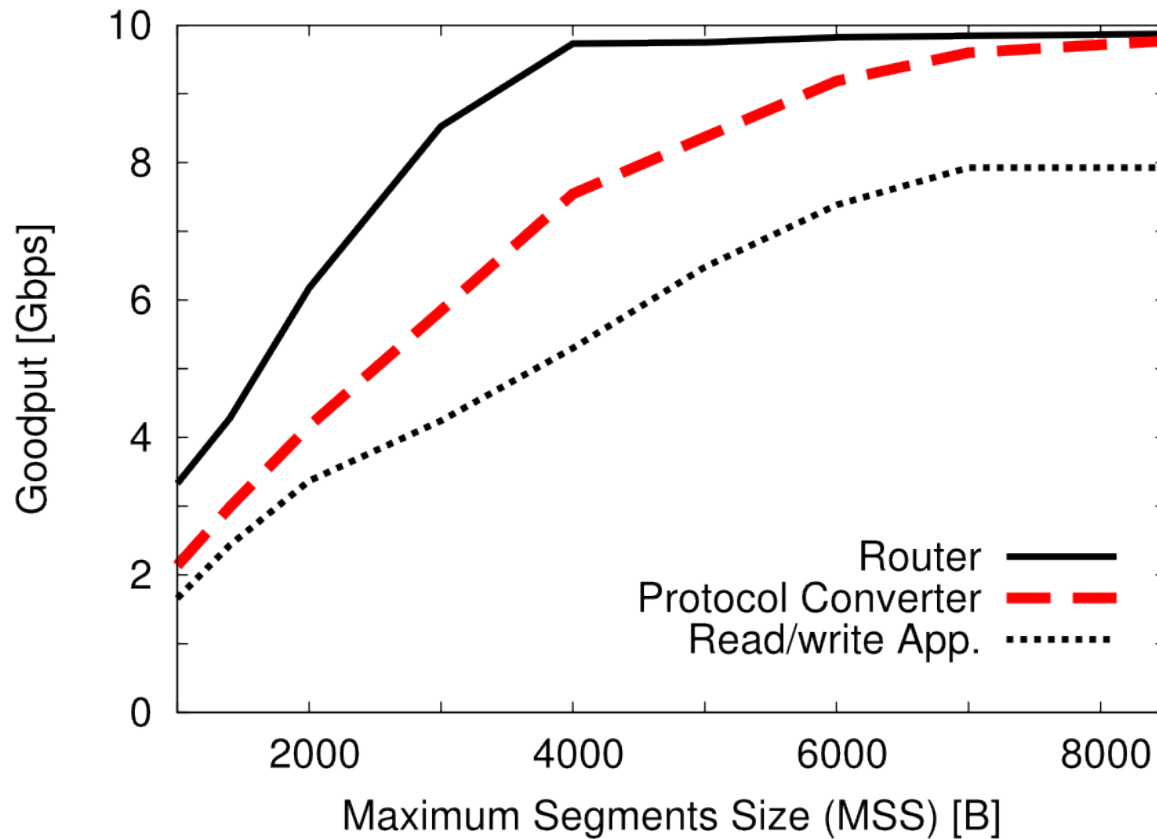

Video



Video

- Remote-Desktop to a TCP-only Windows server, passing by the Protocol Converter.

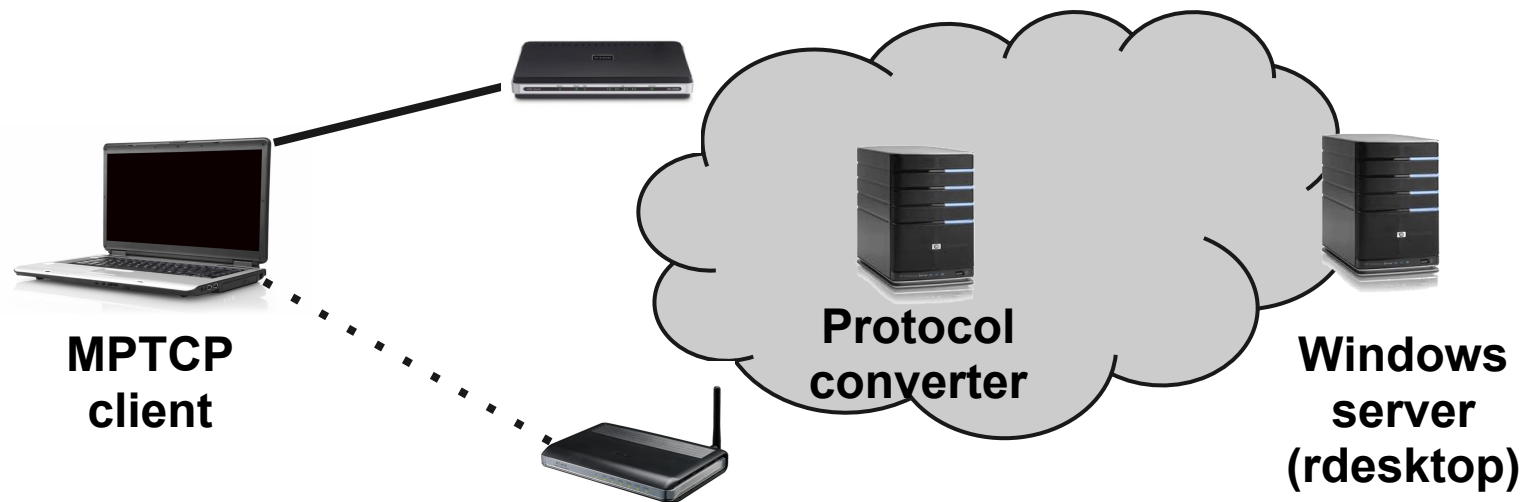

- Connection is not lost after unplugging the Ethernet cable.