

SNMP MIBs to manage G.698.2 parameters

draft-galikunze-ccamp-g-698-2-snmp-mib-02.txt

Gabriele Galimberti
Ruediger Kunze
Lam, Hing-Kam
Dharini Hiremagalur

Cisco Systems
Deutsche Telekom
Alcatel-Lucent
Juniper Networks

Motivation & Problem statement

- ITU-T G.698.2 defines the Application Codes and their optical parameters to operate a DWDM system in a Black Link approach
- ITU-T G.694.1 giving us the Lambda definition

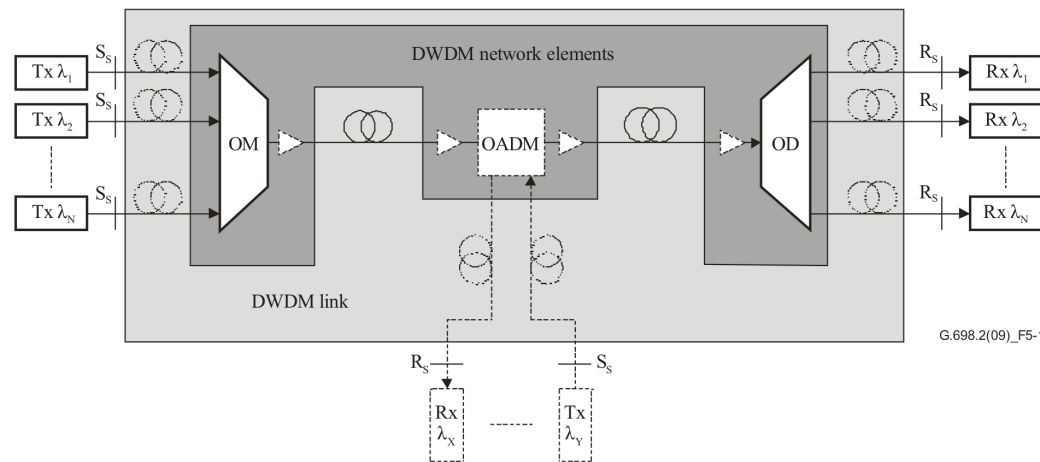

GOAL of the draft:

- Provide a standard way to retrieve/set the ITU-T application codes & parameters from / to the network
- Support EMS/NMS and simple browsers to access the optical parameters
- Give a common simple way to share information on optical parameters across the vendors and operators

Managed parameters

PARAMETERS	Get/Set	Reference
Minimum channel spacing	G	G.698.2 S.7.1.1
Bit rate/line coding of opt. trib. signals	G,S	G.698.2 S.7.1.2
FEC Coding	G,S	G.975
Maximum bit error ratio (BER)	G	G.698.2 S.7.1.3
Fiber type	G,S	G.698.2 S.7.1.4
Wavelength Range	G	G.694.1 S.6
Wavelength Value	G,S	G.694.1 S.6
Vendor Transceiver Class	G	N.A.
Single-channel application codes	G	G.698.2 S.5.3

Table 1: General parameters

PARAMETERS	Get/Set	Reference
MAX and min mean channel output power	G,S	G.698.2 S.7.2.1
Min and MAX central frequency	G	G.698.2 S.7.2.2
MAX spectral excursion	G	G.698.2 S.7.2.3
MAX transmitter (residual) disper. OSNR penalty	G	G.698.2 S.7.2.7
MAX side mode suppression ratio, min channel extinction ratio, Eye mask	G	G.698.2 S.7.2.6
Current Laser Output power	G,S	N.A.

Table 2: parameters at Ss

Managed parameters

PARAMETERS	Get/Set	Reference
MAX and min (residual) chromatic dispersion	G	G.698.2 S.7.3.2
Min optical return loss at Ss	G	G.698.2 S.7.3.3
MAX discrete reflectance between Ss and Rs	G	G.698.2 S.7.3.4
MAX differential group delay	G	G.698.2 S.7.3.5
MAX polarization dependent loss	G	G.698.2 S.7.3.6
MAX inter-channel crosstalk	G	G.698.2 S.7.3.7
MAX interferometric crosstalk	G	G.698.2 S.7.3.8
MAX optical path OSNR penalty	G	G.698.2 S.7.3.9
MAX ripple	G	G.698.2 S.7.3.1

Table 3: parameters between Ss and Rs

PARAMETERS	Get/Set	Reference
MAX and min mean input power	G	G.698.2 S.7.4.1
Min optical signal-to-noise ratio (OSNR)	G	G.698.2 S.7.4.2
Receiver OSNR tolerance	G	G.698.2 S.7.4.3
MAX reflectance at receiver	G	G.698.2 S.7.4.4

Table 4: mandatory parameters at Rs

Standardization activities

- G.698.2 – Defines optical interface parameters for point to point and DWDM systems. G.698.2 support for 2.5G and 10G signals

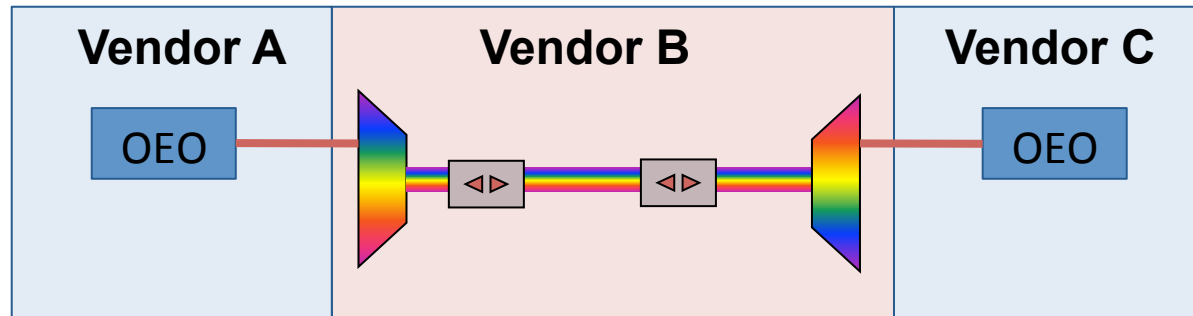

- **standardization activities going forward**
 1. Define 40G and 100G Black Link parameters – ITU effort, leverage existing 698.2 and amend for 40G / 100G
 2. Define means to manage G.698.2 links – IETF effort, leverage SNMP and protocol neutral info model
 3. Enabling G.698.2 information transfer among nodes → LMP protocol
 4. BBF activity on IP - DWDM as per liaison

draft changes from last meeting

- changed the document name :
To : draft-galikusze-ccamp-g-698-2-snmp-mib-02.txt
- Modified:
 - optIfOChOperationalState → (Enable, Disable, Fail status)
 - $\text{Freq} = 193.1 \text{ THz} + n * \text{optIfOChMimumChannelSpacing (Thz)}$ → aligned with G.694.1 definition (as per mailing list comments)
 - Addressed comments
 - Cosmetic changes
- Submitted to opsawg mailing list for comments

Next Steps

- Refine the parameter contents / extension and SNMP MIB structure upon comments
- Realign the Parameters to new ITU-T Rec.
- Promote the draft to WG document
- Add Flex Spectrum parameters / MIB ?
- Keep the interactions to ITU-T to realign the draft to new Recommendation editions
- Questions:
 - Freeze the content document with available parameters and set a new work for its extension ?

QUESTION

- New technology not addressed in this draft but worth to discuss:
 - 400G, 1T – co-ordinate w/ ITU-T
 - Colourless/Directionless/Contentionless ROADMs if any new parameter
 - Flex Spectrum, Super Channel, full coherent networks