

UNI Extensions for Diversity and Latency Support

draft-fedyk-ccamp-uni-extensions-02

IETF 87 – CCAMP WG

Don Fedyk	Donald.Fedyk@alcatel-lucent.com
Dieter Beller	Dieter.Beller@alcatel-lucent.com
Lieven Levrau	Lieven.Levrau@alcatel-lucent.com
Daniele Ceccerelli	Daniele.Ceccarelli@ericsson.com
Fatai Zhang	ZhangFatai@huawei.com
Yuji Tochio	Tochio@jp.fujitsu.com
Xihua Fu	Fu.Xihua@zte.com.cn

Agenda

- Updates from 01 to 02 version
- Relationship with other CCAMP drafts
- Next steps

Updates from 01 to 02 version

- Diversity part for dual-homed CEs:
 - Two mechanisms defined how to achieve path diversity within the provider network (exchange of SRLG information via the CE device or usage of Path Affinity Set object [level of indirection])
 - No update
- Latency part:
 - New text added to “Latency Signaling Extensions” section; RSVP-TE extensions at the UNI based on extensions defined in [draft-ali-ccamp-rc-objective-function-metric-bound-02.txt](#)
- References updated
- Draft fairly stable

Relationship with other CCAMP Drafts

- draft-fedyk-ccamp-uni-extensions-02 is addressing:
 - Path diversity mechanisms for dual-homed CEs (**unique**)
 - Latency constraints from a **CE to CE (e2e) perspective**
 - draft-fedyk-ccamp-uni-extensions-02 complements:
 - [draft-ietf-ccamp-lsp-diversity-02.txt](#)
 - [draft-ali-ccamp-rc-objective-function-metric-bound-02](#)
 - [draft-ali-ccamp-extended-srlg-00.txt](#)
- these drafts are addressing signaling extensions to support LSP diversity and SRLGs for multi-domain networks and are focusing on provider network aspects

Next Steps

- Solicit feedback/comments from the group
- Further completion/refinement
- Ready for WG status?
- Collaboration with authors working on other GMPLS UNI related drafts such as:
 - [draft-farrel-interconnected-te-info-exchange-00.txt](#)
 - [draft-ceccadedios-ccamp-overlay-use-cases-01.txt](#)
 - [draft-zhang-ccamp-gmpls-uni-app-04.txt](#)
 - [draft-ali-ccamp-gmpls-uni-error-notification-00.txt](#)

Thank You!

Backup Slides

Dual-homing Problem Statement

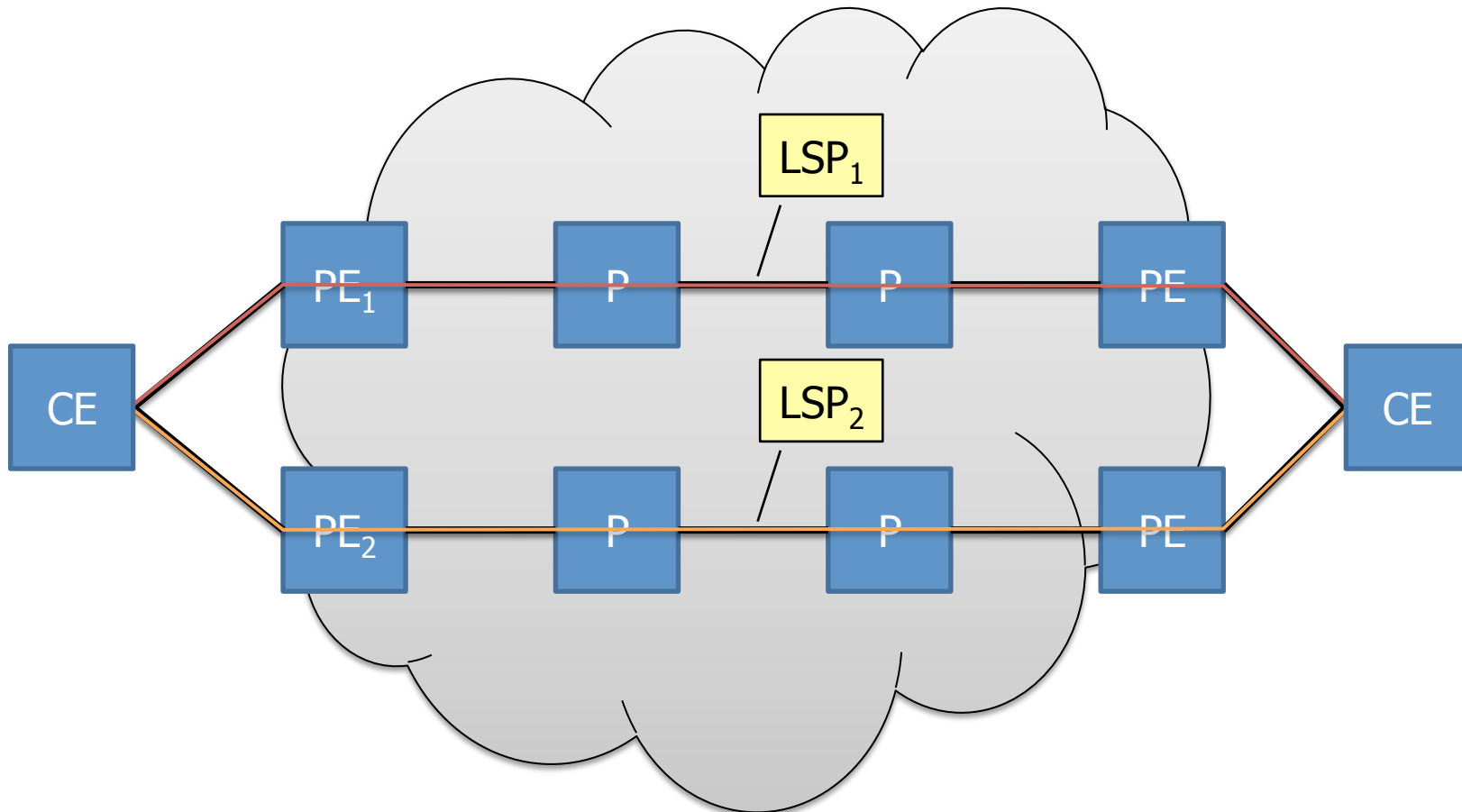

Problem Statement: ensure that LSP1 and LSP2 are mutually disjoint

Option 1: Exchange of SRLG List

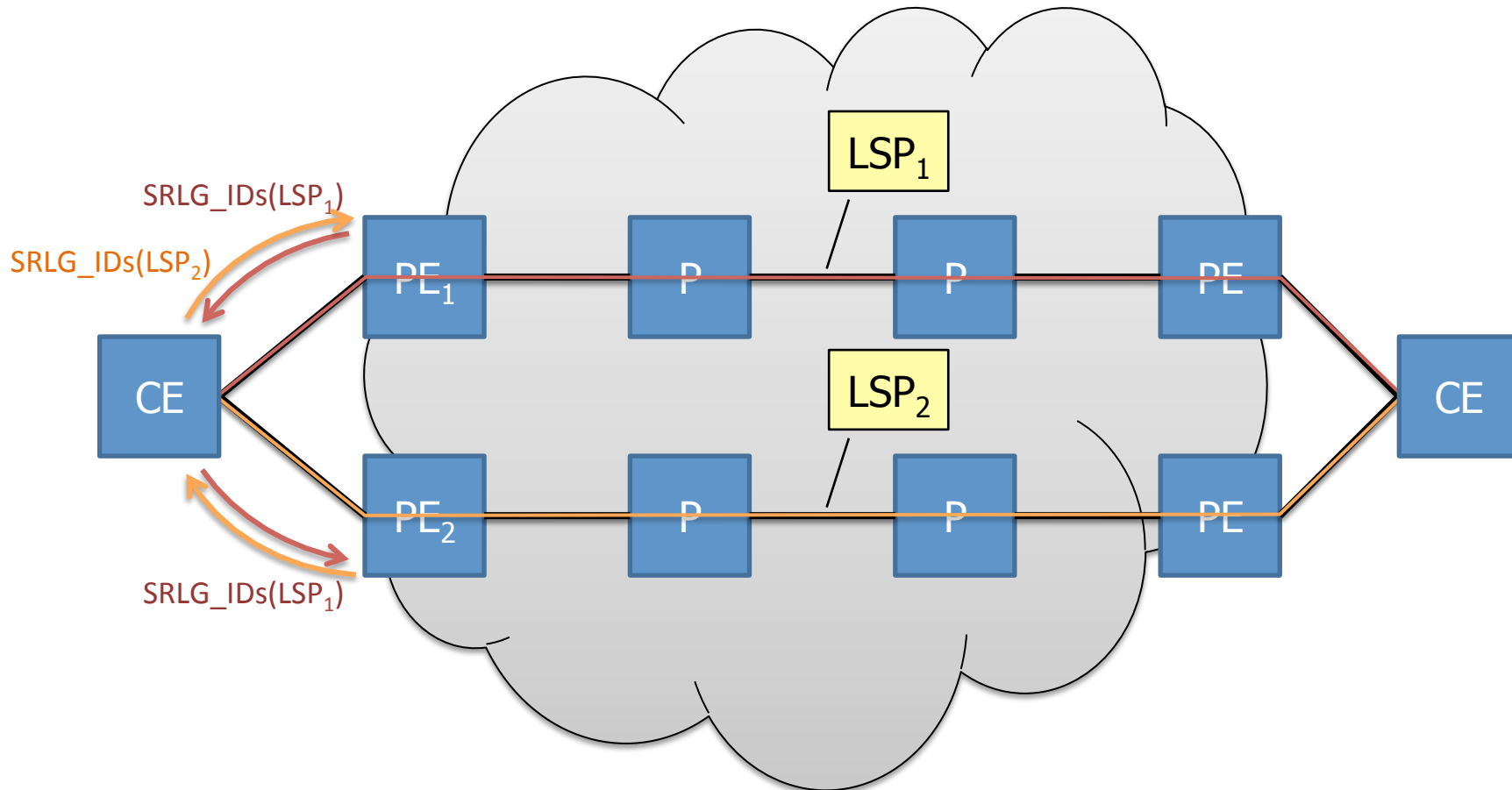

Exchange of SRLG ID list for disjoint LSPs via source CE node

Option 2: Exchange of Path Affinity Set

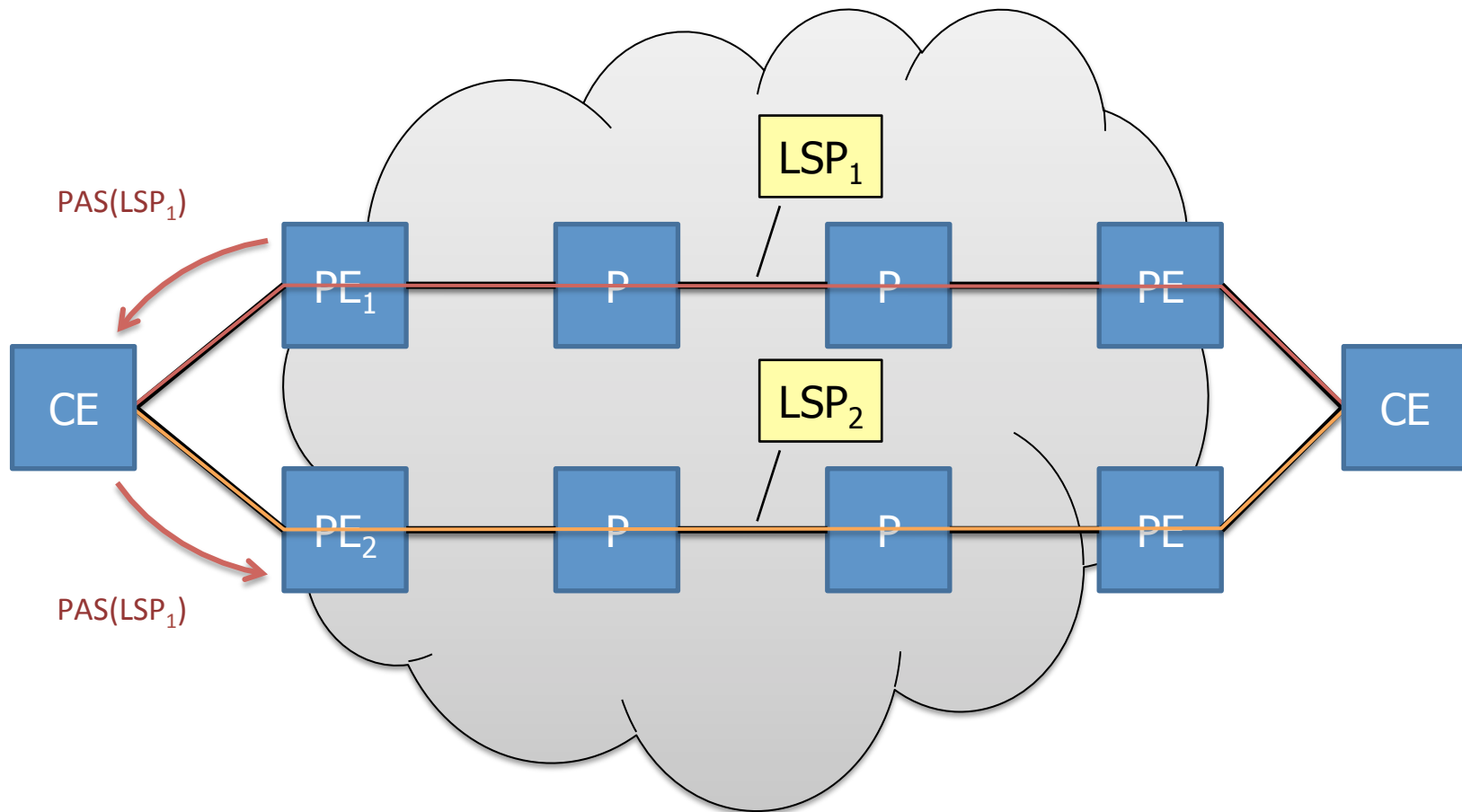

- Exchange of PAS + LSP ID via source CE node
- Dissemination of (PAS, LSP ID, SRLG IDs) among PEs for each L1VPN