

Linux Kernel MPTCP Status Update

<http://multipath-tcp.org>

Reflections on v0.86

- Released 13th March 2013 prior to IETF86
- 7 maintenance releases (v0.86.7)

Reflections on v0.86

- Fixes to middlebox-support, reported by:
 - Citrix
 - Benjamin Hesmans (UCLouvain) Click-middleboxes
- More Bug-Fixes, reported by:
 - Per Hurtig (Karlstad University)
 - Gregory Detal (UCLouvain)
 - Shinkai Takumi (Okayama University)
 - Ronald Velt (TNO)
 - Ramin Khalili (T-Labs/TU-Berlin)

MPTCP v0.87

New Release, available at
<http://multipath-tcp.org>

MPTCP stable Release v0.87

New Features:

- Hardware offloading (by Gregory Detal)
- Zero-copy support - sendfile(), splice()
- NET_DMA support
- More performance improvements
- NFS-support
- TCP-urgent pointer fixes (by Cristina Ciocan)
- ...

MPTCP v0.87 Performance

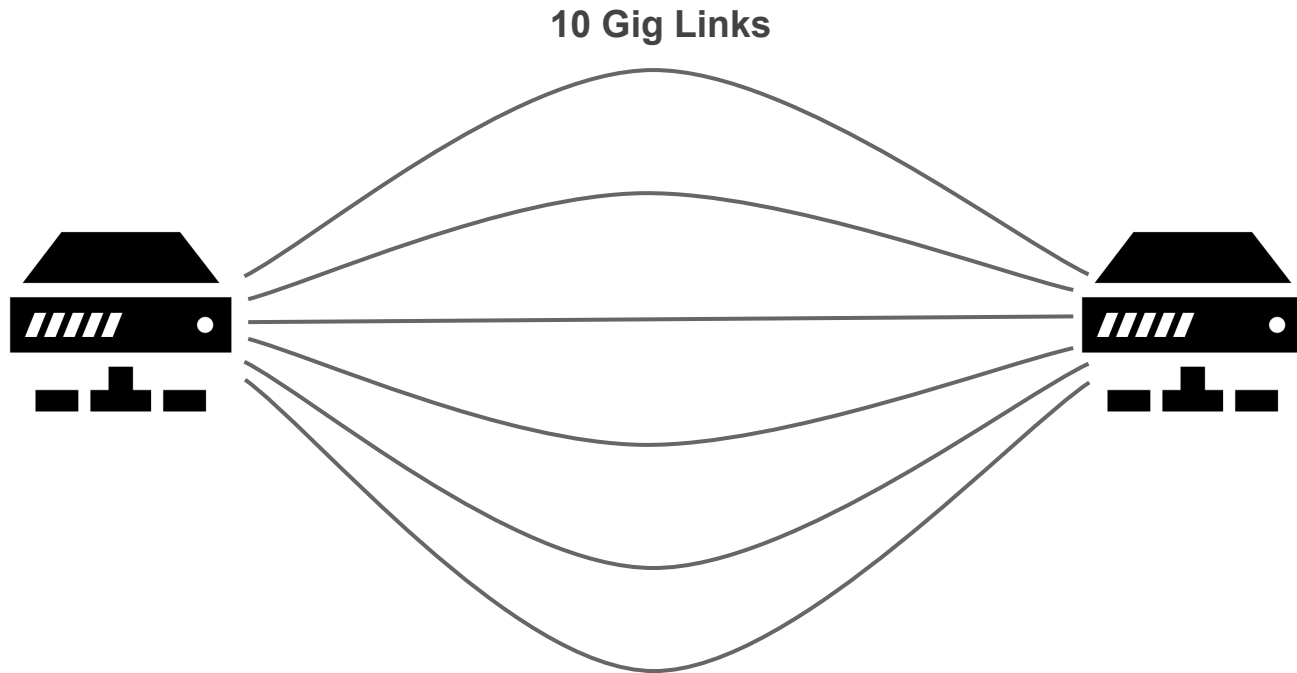

MPTCP Middlebox Traversal

Benjamin Hesmans, Fabien Duchene,
Christoph Paasch, Olivier Bonaventure

UCLouvain - IP Networking Lab

Testing MPTCP Middlebox Traversal

- Click-elements to reproduce middlebox-behavior
- Large measurement campaign to cover real networks

Active FTP with MPTCP

- FTP in active mode allows the server to initiate the data-connection
- NATs with FTP-support modify the IP-address in the FTP PORT-command

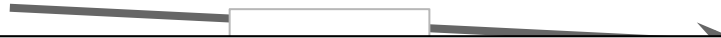

Does MPTCP works in this environment?



Active FTP with MPTCP

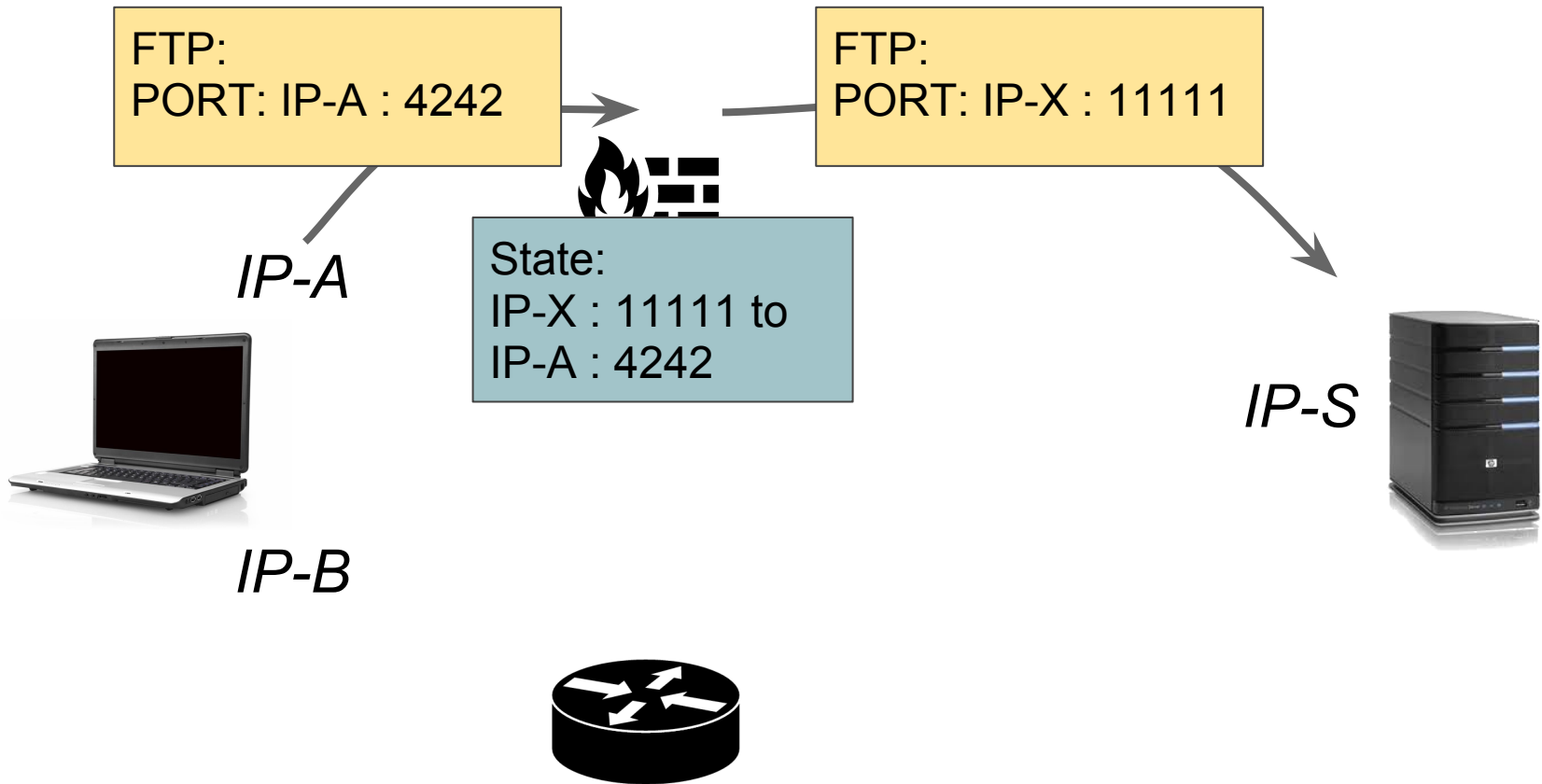

Active FTP with MPTCP

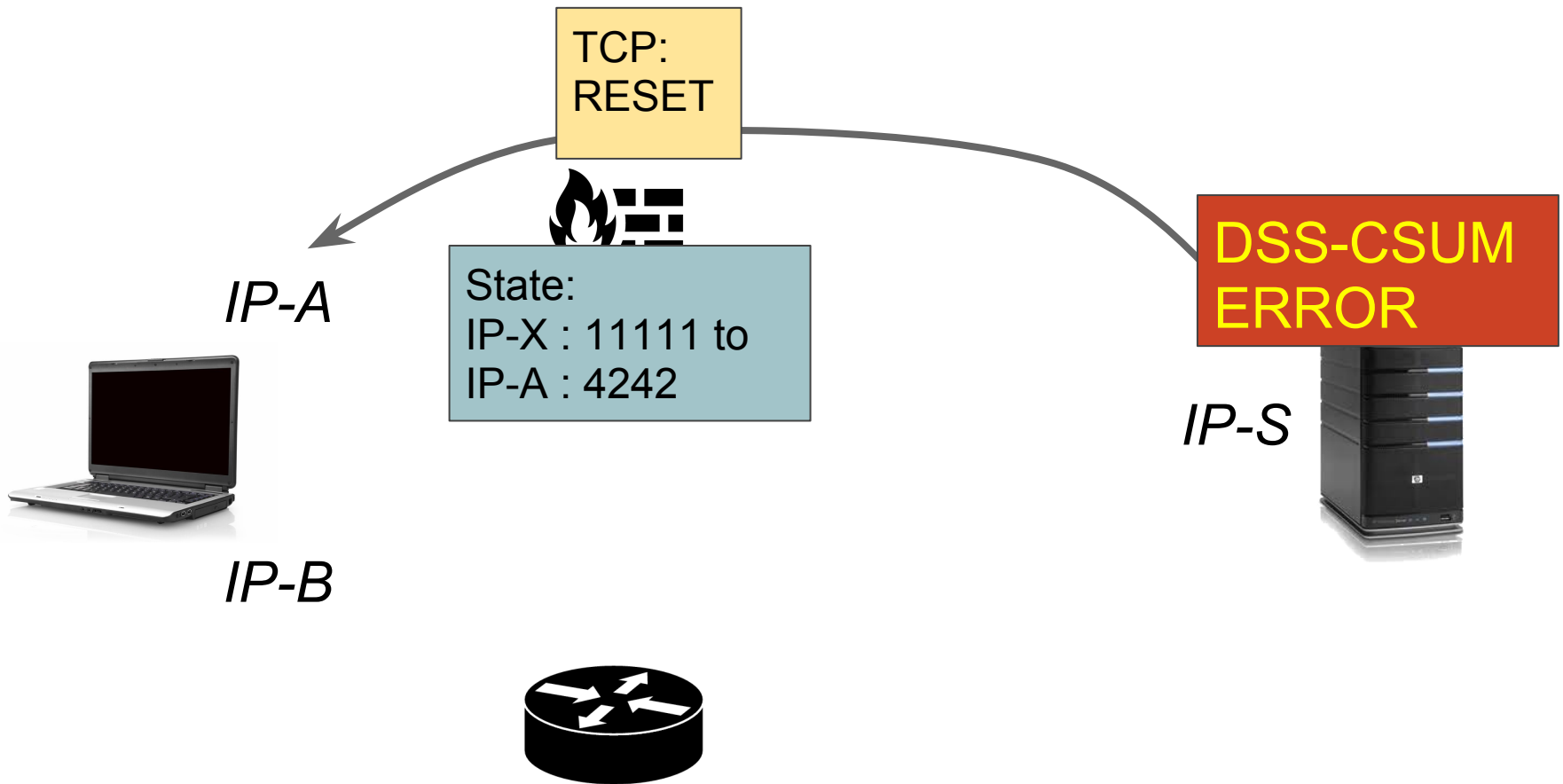

Active FTP with MPTCP

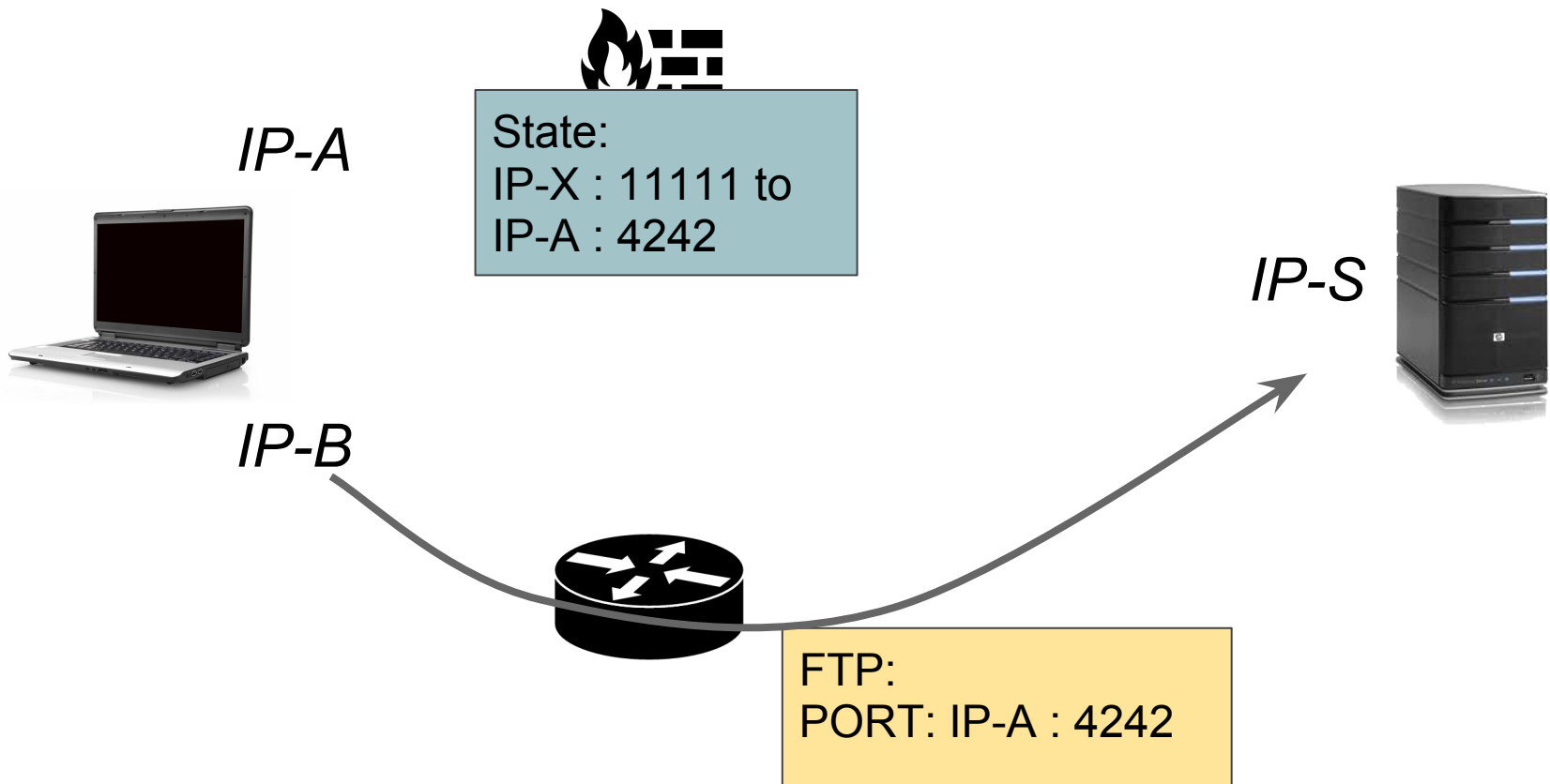

Active FTP with MPTCP

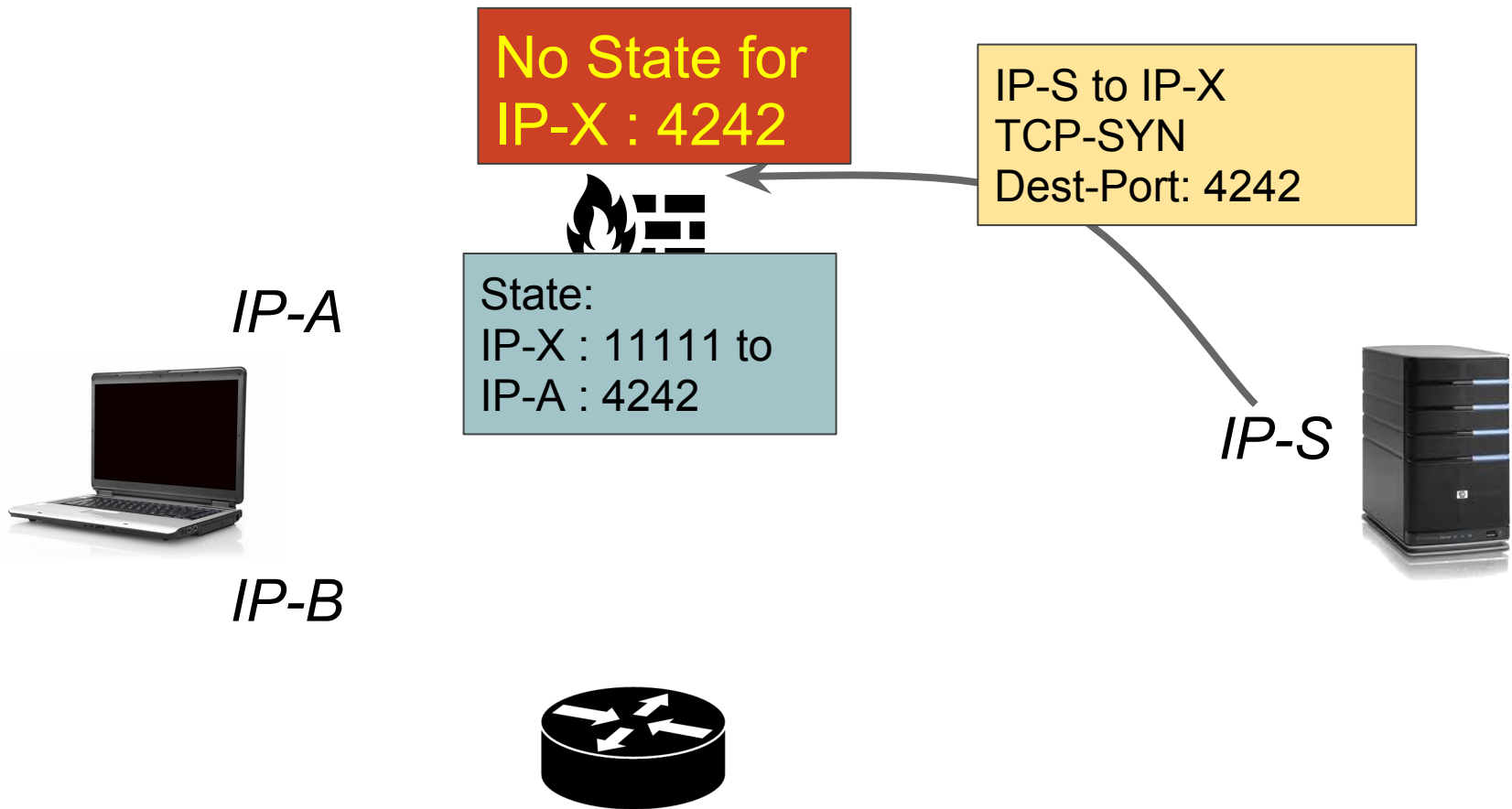

Active FTP with MPTCP

- FTP in active mode may have problems with Multipath TCP
- No trivial solution to this problem

MPTCP across TCP Normalizers

- Monitor window-variation
- If window shrunk, may drop the connection

MPTCP across TCP Normalizers

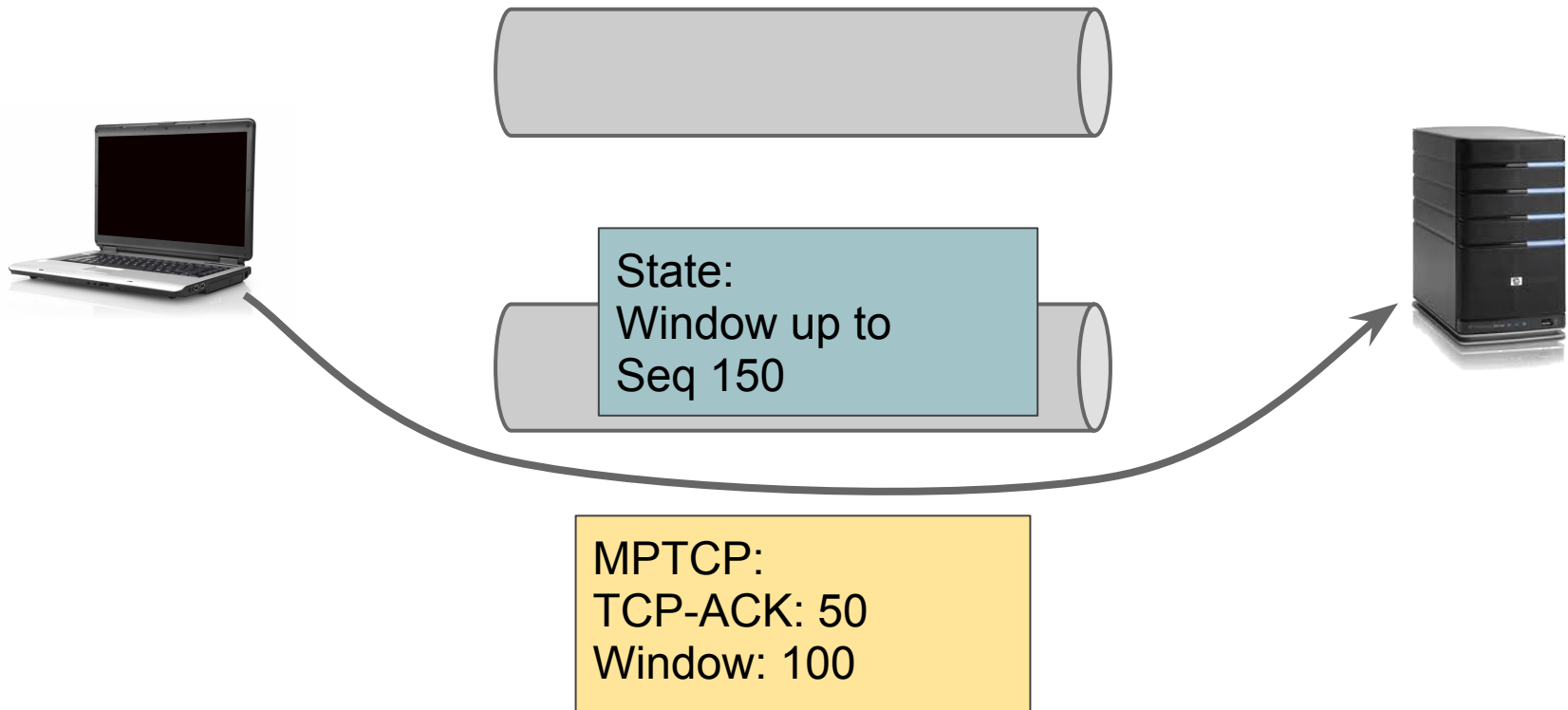

MPTCP across TCP Normalizers

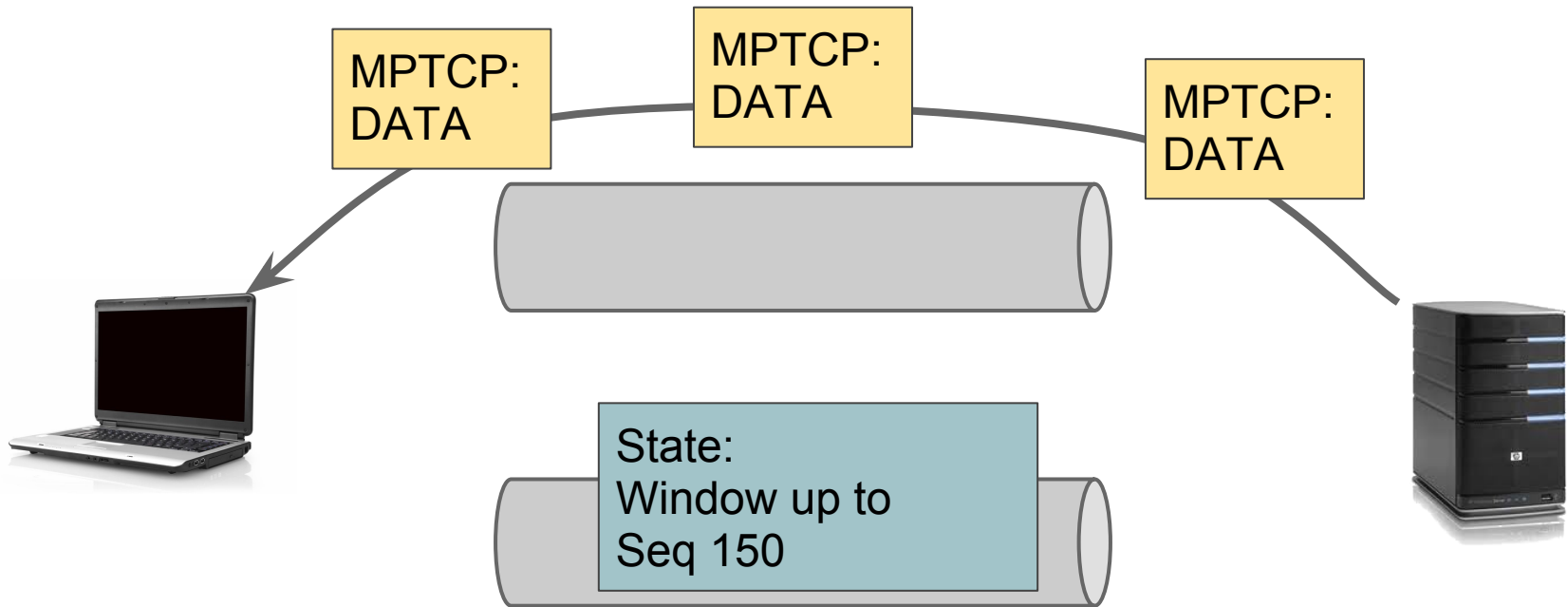

MPTCP across TCP Normalizers

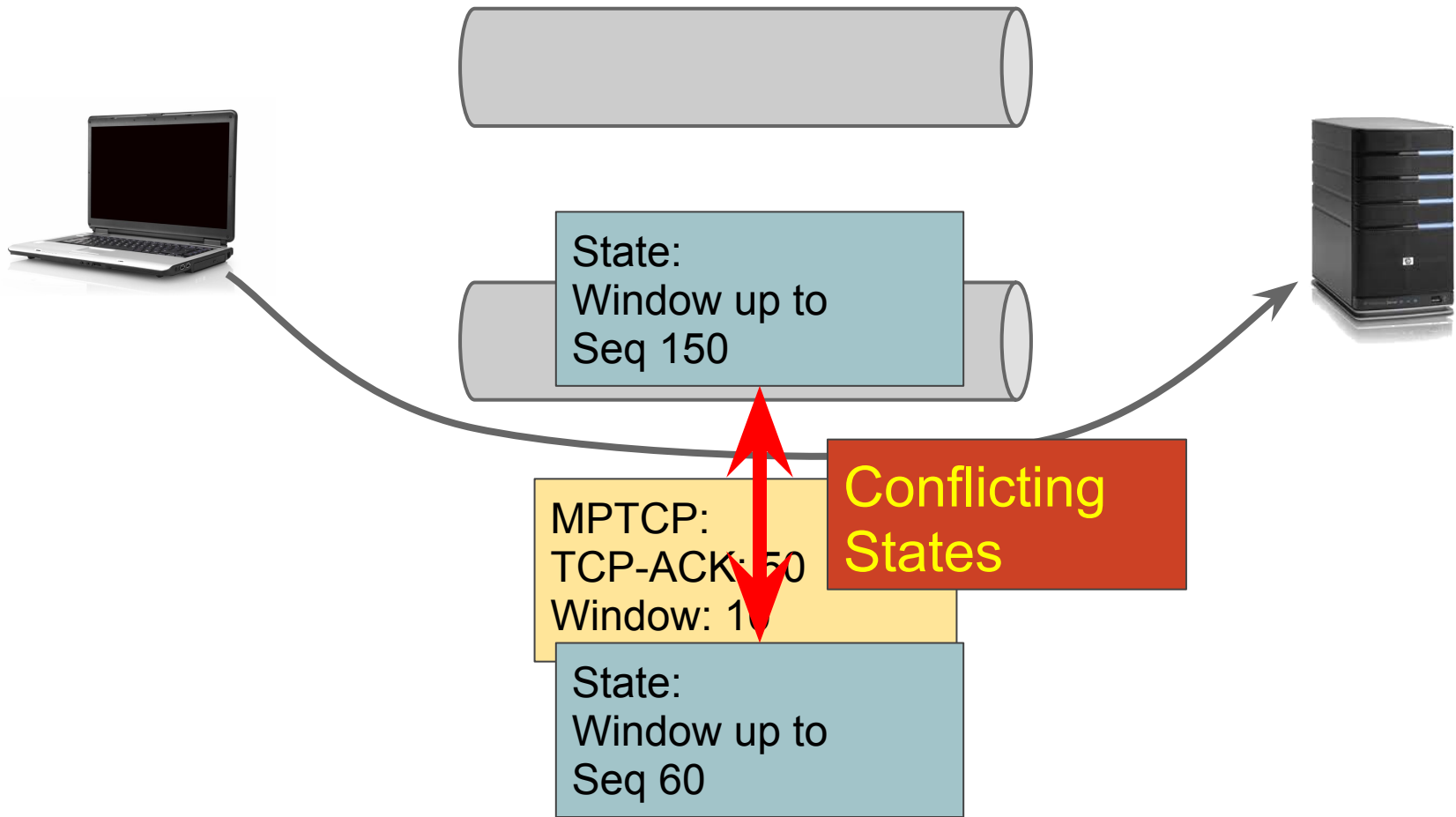

MPTCP across TCP Normalizers

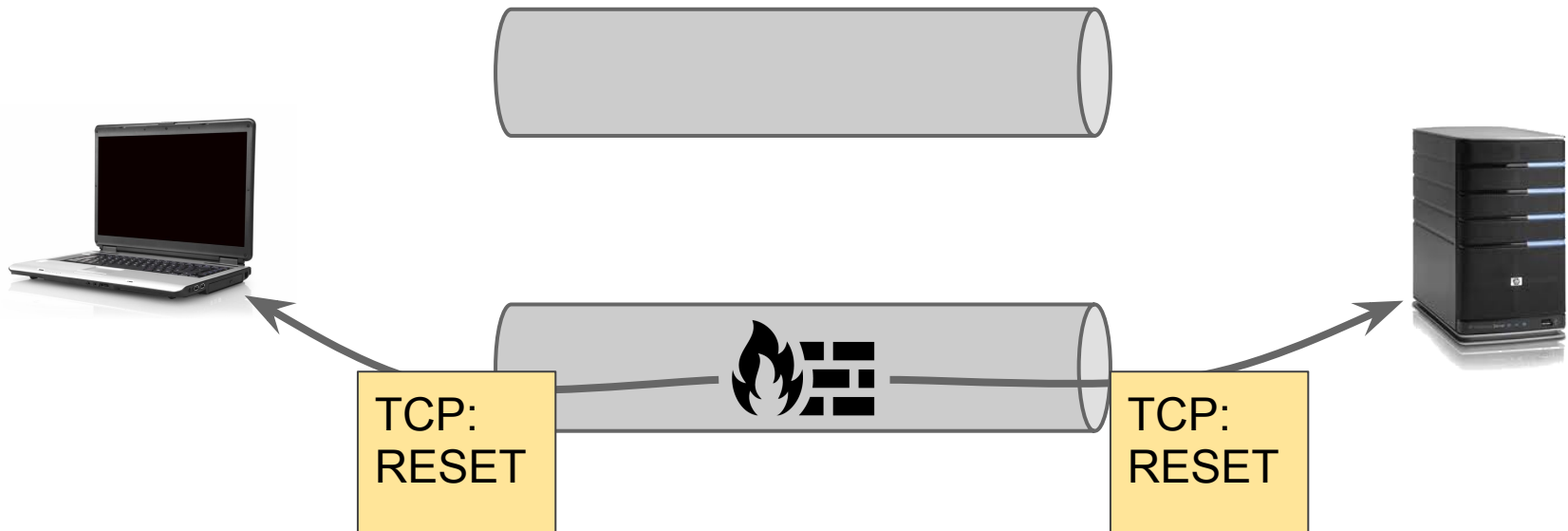

MPTCP across TCP Normalizers

- MPTCP should probably not modify the window in the TCP-header
- Announce the MPTCP-level window in the DSS-option ?