

Covering Prefixes Outbound Route Filter for BGP-4

draft-bonica-l3vpn-orf-covering-prefixes-00

H. Jeng - AT&T

R. Bonica – Juniper Network

Y. Rekhter – Juniper Networks

Overview

- Define a new ORF-type, called the "Covering Prefixes ORF (CP-ORF)"
- CP-ORF is applicable Virtual Hub-and-Spoke VPN's (RFC 7024)
 - May also be applicable in other environments

VIRTUAL HUB-AND-SPOKE VPN: A BRIEF REVIEW

Goal

- Reduce the number of routes that V-Spoke1 carries
- V-Spoke1 carries only one IP Default route per VPN
 - Next-hop == V-Hub1
- Traffic from V-Spoke1 traverses V-Hub1
- Traffic to V-Spoke 1 may traverse a more direct route

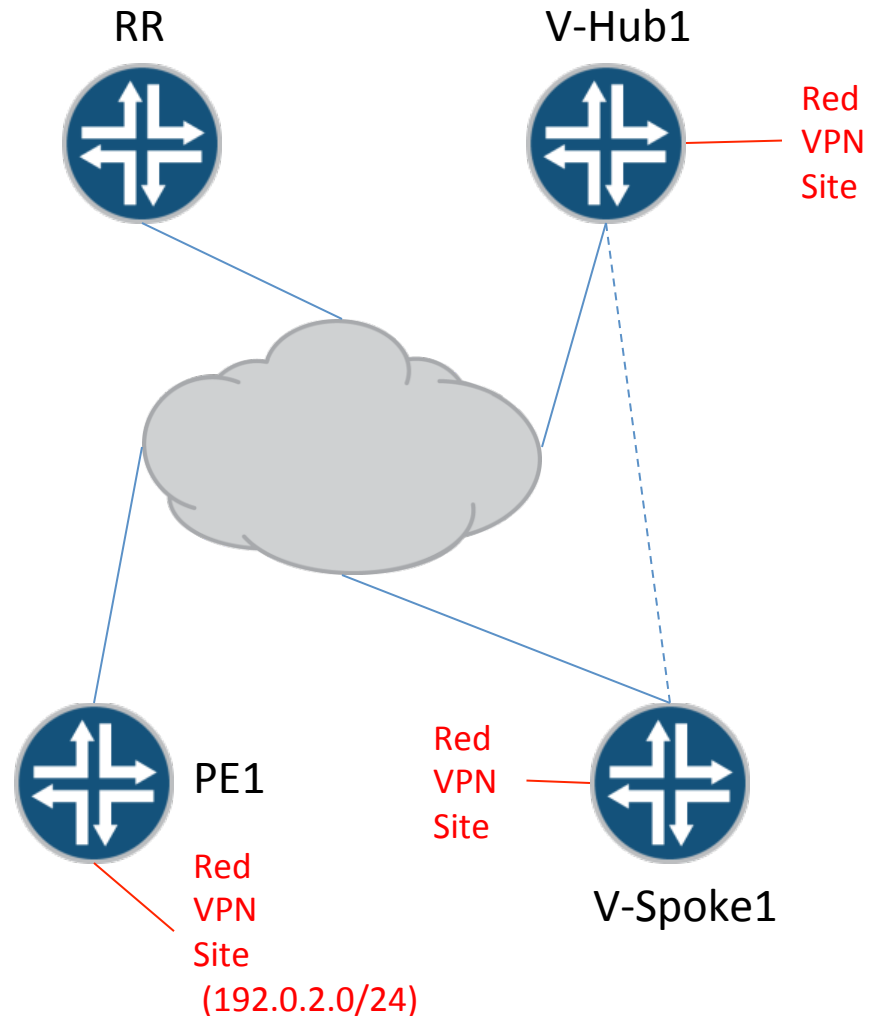

BGP Routing Policy

- PE1 and V-Hub1 are clients of a RR
 - V-Spoke1 may be client of RR or V-Hub1
- PE1 and V-Hub1 accept advertisements carrying the RT, RT-RED
- V-Spoke1 accepts advertisements carrying the RT, RT-RED-FROM-HUB1

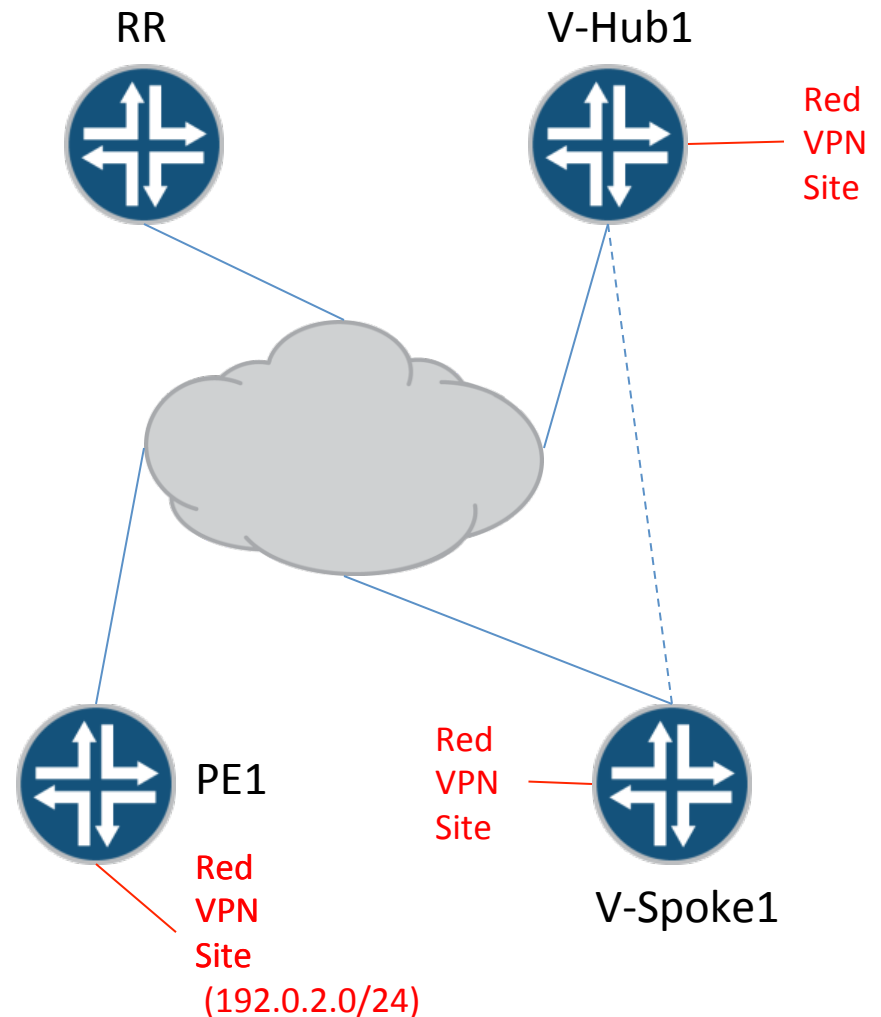

BGP Advertisements

- PE1 advertises 192.0.2.0/24 to the RR
 - Next-hop = Self
 - RT = RT-RED
- RR reflects route to V-Hub1
 - V-Hub1 accepts
- RR may also advertise route to V-Spoke1
 - In absence of RT-Constrain
 - If advertised, V-Spoke1 rejects

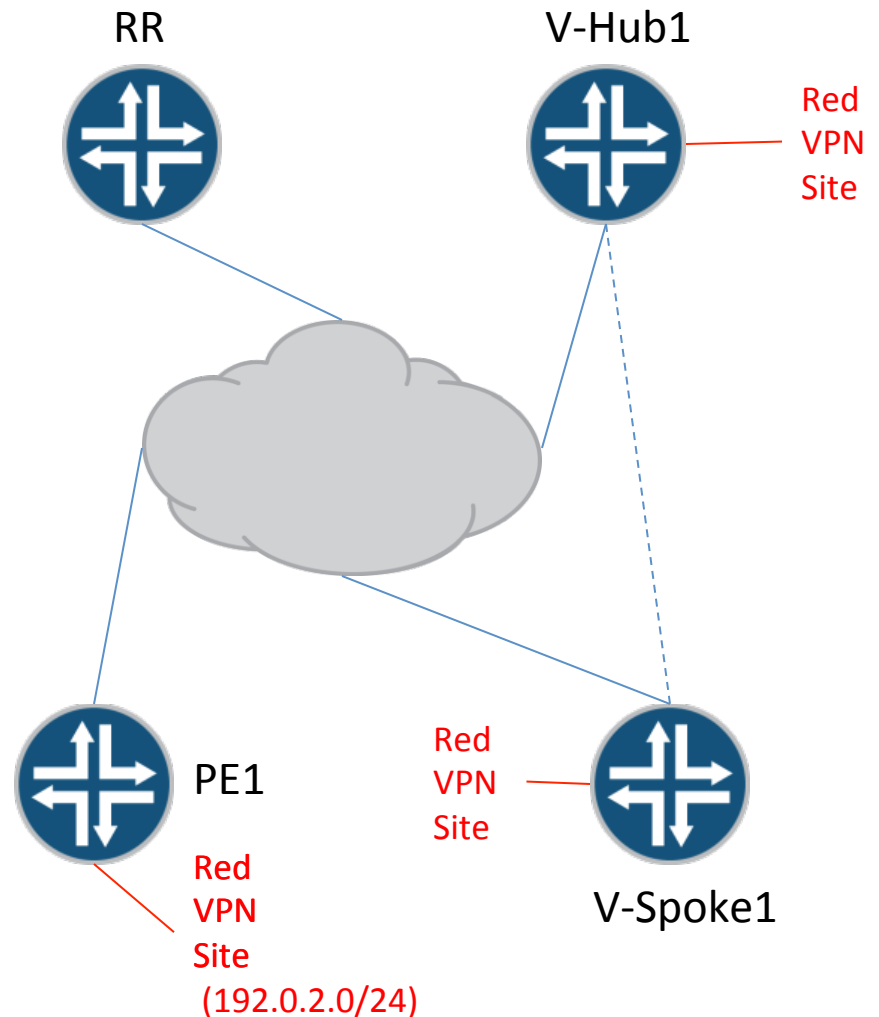

BGP Advertisements (continued)

- V-Hub1 advertises VPN-IP default route to the RR
 - Next-hop = Self
 - RT = RT-RED-FROM-HUB1
- RR reflects route to V-Spoke1
 - V-Spoke1 accepts

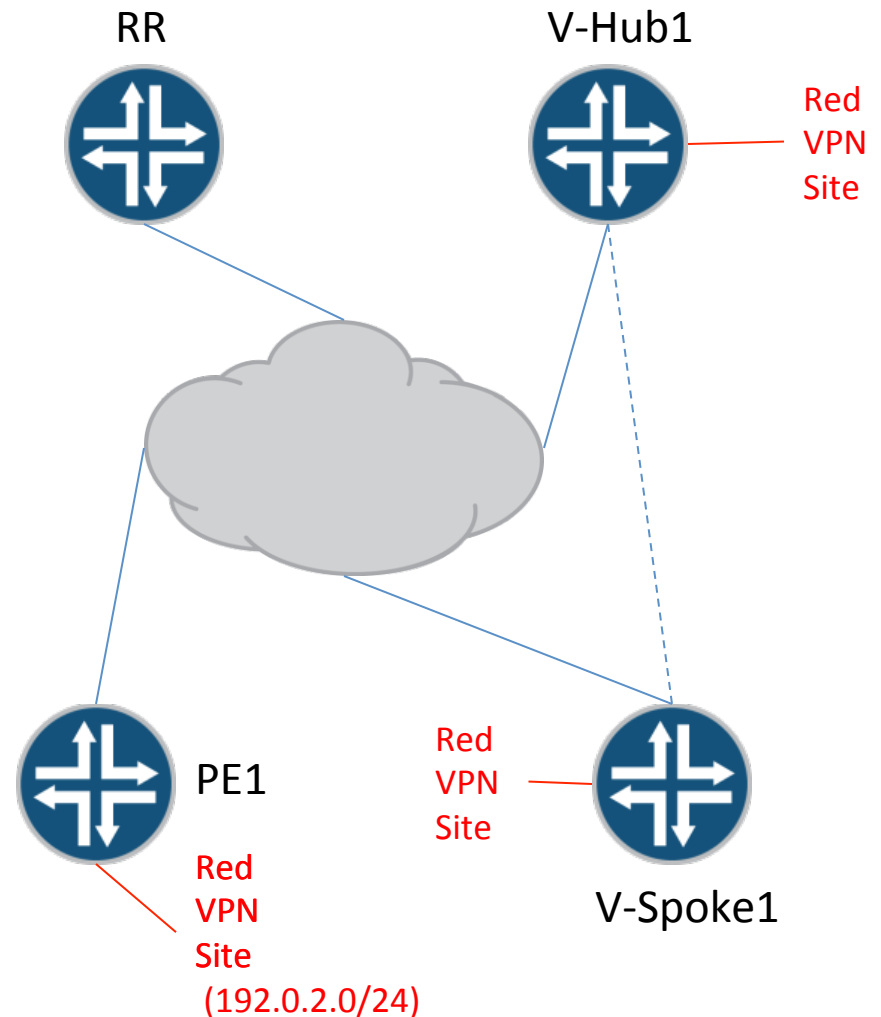

COVERING PREFIX ORF

Problem to Be Solved

- The VPN site served by V-Spoke1 originates an “exceptional” flow to 192.0.2.1
 - Large, latency sensitive, etc.
- Flow traverses V-Hub1
- Flow might benefit from a more direct route to 192.0.2.1
 - If such a route exists
- The criteria determining that a flow might benefit from a more direct route are strictly local to V-Spoke1

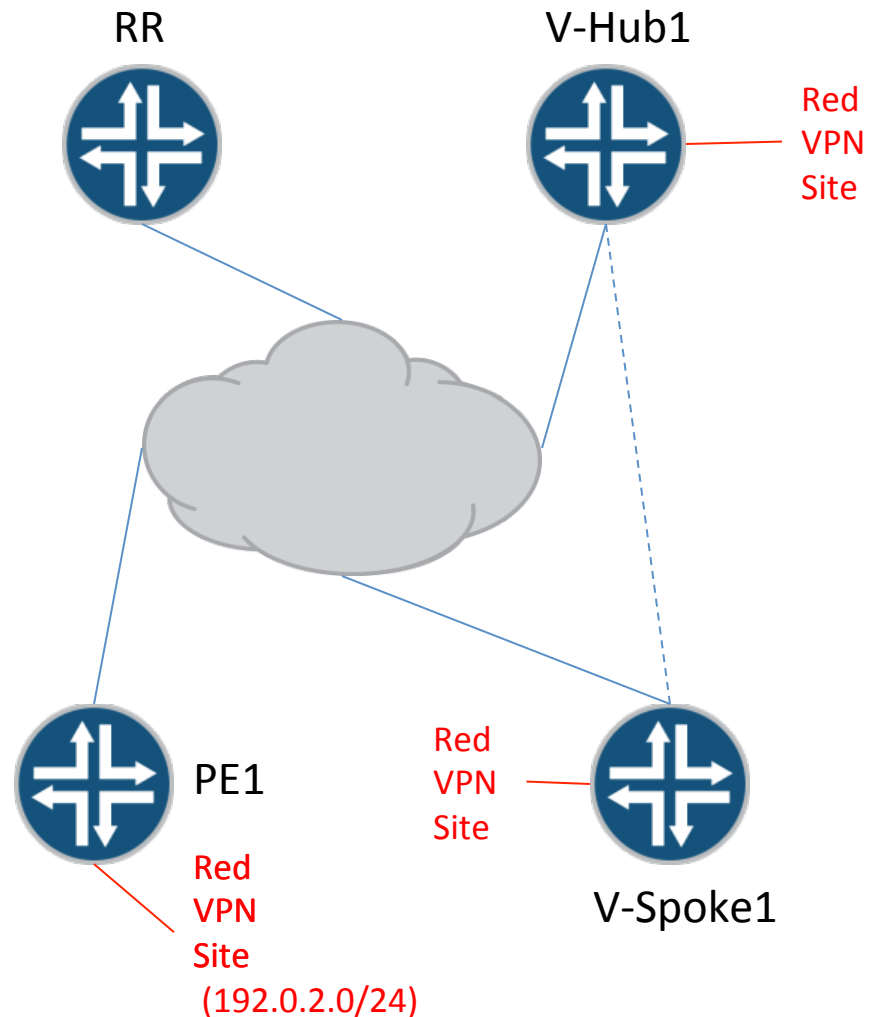

Solution

- V-Spoke1 requests the most specific route covering 192.0.2.1 from the RR
 - Carrying additional RT, RT-RED-FROM-HUB1
- Pull versus push

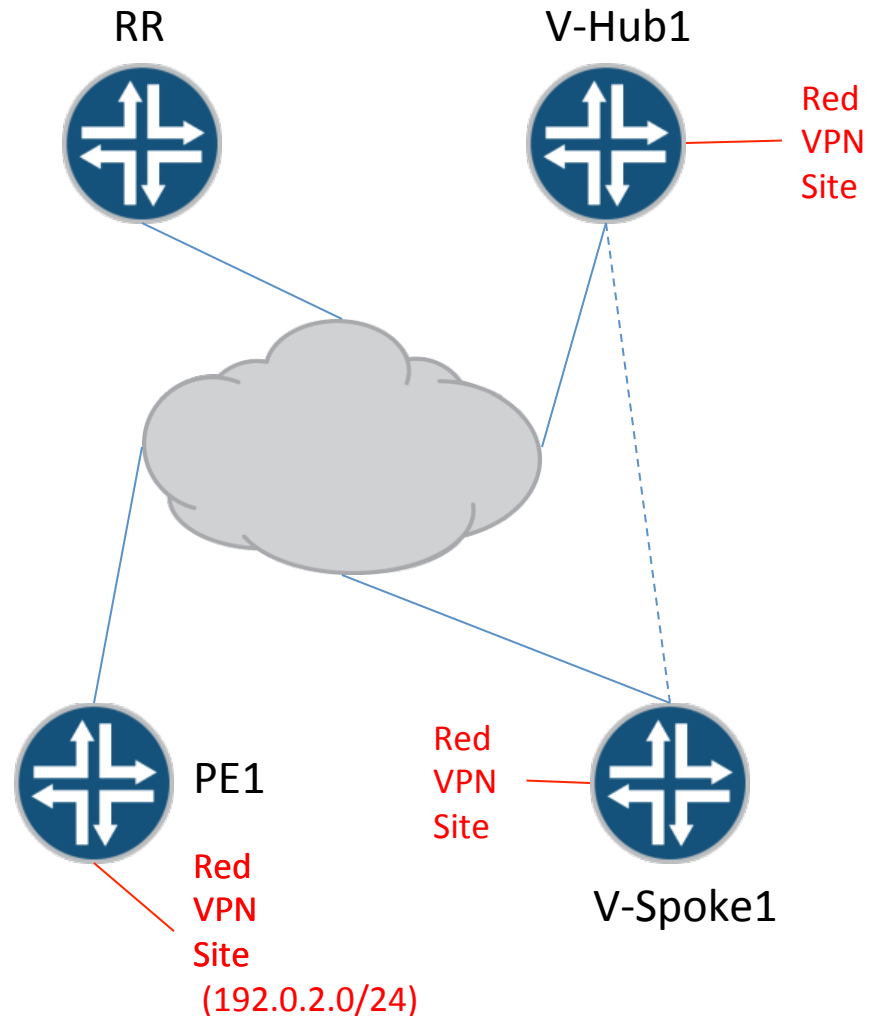

Solution In Detail

- At startup, V-Spoke1 establishes BGP session with RR
 - Negotiates CP-ORF Capability
 - Negotiates Multiprotocol Extensions Capability
- V-Spoke1 sends RR a Route Refresh message containing no ORF entries
 - RR sends V-Spoke1 IP VPN default route
 - Next-hop = V-Hub1
 - RT = RT-RED-FROM-HUB1
- Later, V-Spoke1 detects an “exceptional” flow to 192.0.2.1
- V-Spoke1 sends RR a Route Refresh message containing CP-ORF entry
 - RR refreshes advertisements to V-Spoke1, sending longest route covering 192.0.2.1 (i.e., 192.0.2.0/24)
- V-Spoke1 periodically withdraws ORFs that are no longer required

Route Refresh Message With CP-ORF

- AFI = IPv4 or IPv6
- SAFI = MPLS-Labeled-VPN-Address
- When-to-refresh = IMMEDIATE
- ORF Type = CP-ORF (value TBD)
- ORF entry
 - Action = ADD
 - Match = PERMIT
 - Type Specific Information

CP-ORF Type Specific Information

Sequence (32 bits)
VPN Route Target (64 bits)
Import Route Target (64 bits)
Host Address (32 or 128 bits)

Solution In Detail: RR Perspective

- RR validates ROUTE REFRESH
 - Ignore entire message if invalid
- Install CP-ORF
- Refresh routes, evaluating with CP-ORF
- CP-ORF match conditions
 - the route is more specific than a /64
 - the route carries RT whose value is the same as the CP-ORF VPN Route Target
 - the route covers the CP-ORF Host Address
- Add Import Route Target to the matching route

Conclusion

- Adopt as WG draft