

I E T F[®]

Extension of the MLD proxy functionality to support multiple upstream interfaces

<draft-contreras-pim-multiple-upstreams-00.txt>

Luis M. Contreras
Telefónica I+D

Carlos J. Bernardos
Universidad Carlos III de Madrid (UC3M)

Juan Carlos Zúñiga
InterDigital

Vancouver, MBONED WG, November 2013

Proposal Status

- The draft covers a number of use cases where an MLD proxy functionality supporting more than one upstream interface would be useful
- A number of requirements for those scenarios are collected
- A functional specification is not yet described
- Draft history:
 - Initial versions submitted to MULTIMOB WG as the original use case was motivated there
 - Presented to both MULTIMOB and PIM WGs in Atlanta (85th) and Orlando (86th) IETF meetings
 - Presented to PIM WG in Berlin (87th) meeting, suggested to be presented to the MBONED community

Problem statement

- General application:
 - Sharing of a common network access infrastructure among different multicast content providers
- Advantages
 - Subscribers can get their preferred contents from different multicast content providers without network constraints and without requiring PIM routing on the access / aggregation device
 - Redundancy

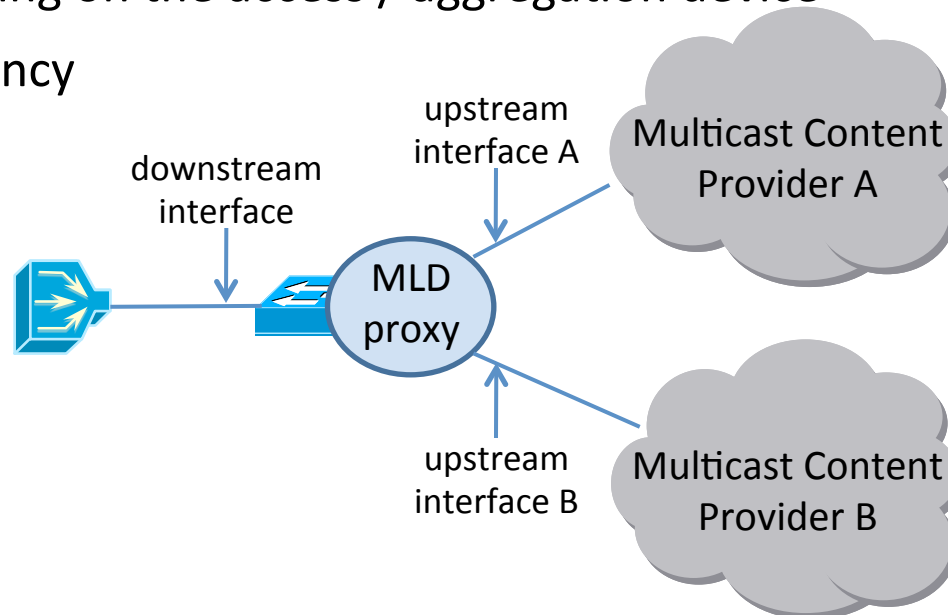

Motivation

- The support of multiple upstream interfaces on an MLD proxy functionality has been identified as an opportunity for system optimization
- Complexity
 - Handling of control messages for/from multiple upstreams
 - Efficient handling of data traffic for/from multiple upstreams
- Purpose
 - Identification of requirements for supporting multiple upstreams
 - Specification of the needed MLD proxy functional extensions

Network communication scenarios

- Fixed broadband based
 - Residential broadband users get access to multiple IP services through fixed network infrastructures
 - End user equipment is connected to an access node (AN), traffic from multiple accesses is collected in aggregation switches
 - Use of an MLD-Proxy with multiple upstream interfaces can be lighter and simpler than using PIM-routing alternatives

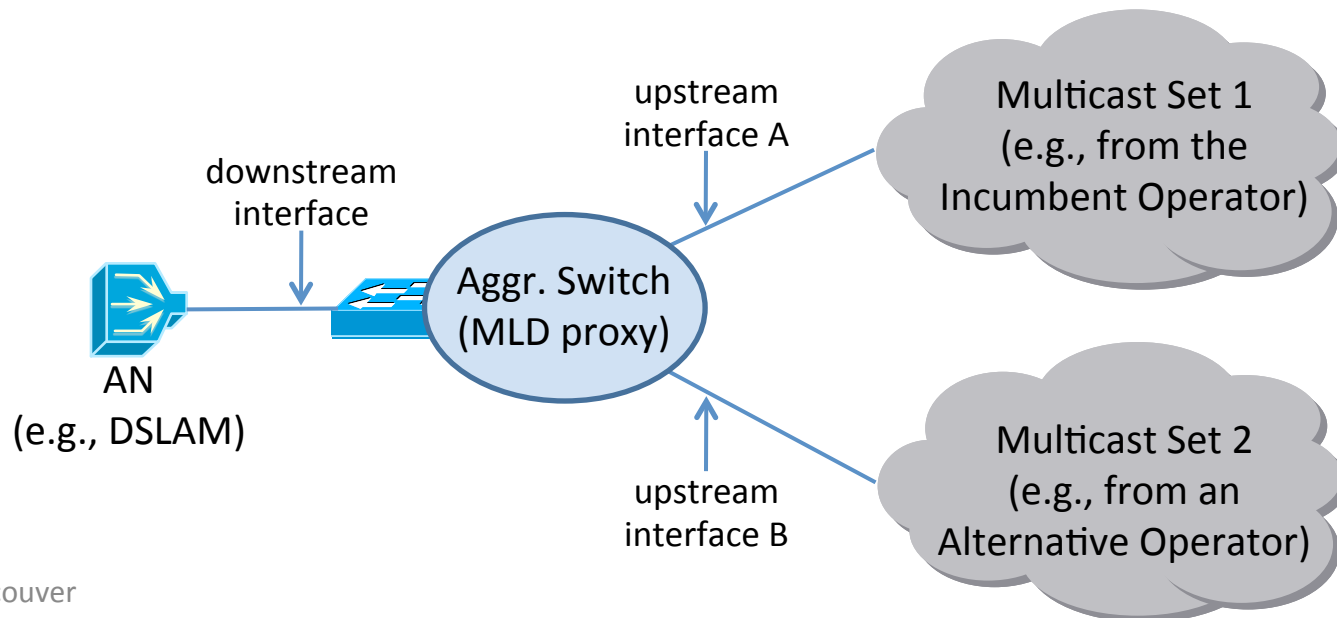

Fixed network communication scenarios (I)

- Multicast wholesale offer for residential services
 - ✓ (Introduced before) Complementary multicast service offered by alternative operators in an efficient manner
 - ✓ Operators can offer multicast streams that can be subscribed by the end user, independently of which provider contributes with the content
 - ✓ Requirements
 - ✓ The MLD proxy should be able to deliver multicast control messages sent by the end user to the corresponding provider's multicast router
 - ✓ The MLD proxy should be able to deliver multicast control messages sent by each of the providers to the corresponding end user

Fixed network communication scenarios (II)

- Multicast resiliency
 - ✓ Path diversity through the connection to distinct leaves in a given multicast tree (skipping routing based mechanisms)
 - ✓ It is assumed that only one of the upstream interfaces is active in receiving the multicast content, while the other is up and in standby for fast switching
 - ✓ Requirements
 - ✓ The MLD proxy should be able to deliver multicast control messages sent by the end user to the corresponding active upstream interface
 - ✓ The MLD proxy should be able to deliver multicast control messages received in the active upstream to the end users, while ignoring the control messages of the standby upstream interface
 - ✓ The MLD proxy should be able of rapidly switching from the active to the standby upstream interface in case of network failure, transparently to the end user

Fixed network communication scenarios (III)

- Load balancing for multicast traffic in the metro network
 - ✓ Demand split of multiple channels on different paths, alleviating the bandwidth requirements in the metro segment
 - ✓ Requirements
 - ✓ The MLD proxy should be able to deliver multicast control messages sent by the end user to the corresponding multicast router which provides the channel of interest
 - ✓ The MLD proxy should be able to deliver multicast control messages sent by each of the multicast routers to the corresponding end user
 - ✓ The MLD proxy should be able to decide which upstream interface is selected for any new channel request according to defined criteria (e.g., load balancing).

Fixed network communication: Summary

	Fixed Network Scenarios		
Functionality	Multicast Wholesale	Multicast Resiliency	Load Balancing
Upstream Control Delivery	x	x	x
Downstream Control Delivery	x	x	x
Active / Standby Upstream interface		x	
Upstream i/f selection per mcast group			x
Upstream i/f selection for all groups		x	

➤ Benefits

- ✓ Resource efficiency on distribution network
- ✓ Avoidance of multicast routing complexity as far as possible from the access / aggregation devices

Mobile network communication scenarios

- PMIPv6-based (MULTIMOB)
- Listener mobility
 - ✓ Single MLD proxy instance on MAG per LMA
 - ✓ Remote and local multicast subscription
 - ✓ Dual subscription to multicast groups during handover
- Source mobility
 - ✓ Support of remote and direct subscription in basic source mobility
 - ✓ Direct communication between source and listener associated with distinct LMAs but on the same MAG
 - ✓ Route optimization support in source mobility for remote subscribers

➤ Benefits

- ✓ Traffic routing optimization within the PMIPv6 domain
- ✓ Simultaneous support of remote and local multicast subscription
- ✓ Avoidance of multiple MLD proxy instances on MAG

Needed functionality per mobile scenario

	Multicast Listener			Multicast Source		
Functionality	Single MLD proxy	Remote & Local Subscr.	Dual Subscr. during HO	Direct & Remote Subs.	Listener & Source on MAG	Route Optimiz.
Upstream Control Delivery	x	x	x	x	x	x
Downstream Control Delivery	x	x	x		x	
Upstream Data Delivery				x		x
Downstream Data Delivery	x	x	x		x	
1:1 MN to Upstream Association	x					
1:N MN to Upstream Association		x	x	x	x	x
Upstream i/f selection per mcast group		x				
Upstream i/f selection for all groups			x			
Upstream traffic replication				x		x

Proposed next steps

- Are we missing any scenario?
- Please, review and provide comments
- Extend the scope to cover also IGMP

- Get feedback on the interest in working on this draft as informational document