

The Use Cases for Using PCE as the Central Controller(PCECC) of LSP

draft-zhao-pce-central-controller-use-cases-00

Quintin Zhao, Katherine zhao, Zhenbin Li, (Huawei)
Zekun Ke (Tencent)

IETF 88, Vancouver, BC, Canada

Introduction

- ❑ The existing MPLS networking has become very complex and highly demanding in terms of :
 - robustness, performance, scalability, flexibility, agility, etc.
- ❑ There are multiple solutions in the process to reduce the complexity and satisfy the new requirements with different focus.
- ❑ Migrating to the SDN enabled network from the existing network, helps the service providers to address the complexity and new requirements, for some service providers and network operators they need a solution which has priorities for the following requirements:
 - Simplify the network while keeping existing network feature sets;
 - Satisfy the new service oriented requirements;
 - Evolve easily from the existing network into the SDN enabled network with minimum changes to their existing network;

Introduction (cont)

□ Extending the existing PCE components from the current network to function as the central controller (PCECC) of the SDN network is one choice:

- Satisfy the new service oriented requirements from users;
- Provides all the existing MPLS functionalities including the LDP LSP, RSVP-TE LSP, mLDP/RSVP-TE P2MP LSP;
- Without the deploying the MPLS protocols such as RSVP-TE and LDP.
- Without introducing new protocols into the network
- Without the data plane changes.
- Achieve the goal of having a centralized controller by leveraging the existing PCE tool sets such as stateful PCE, H-PCE, GCO and P2MP PCE etc.

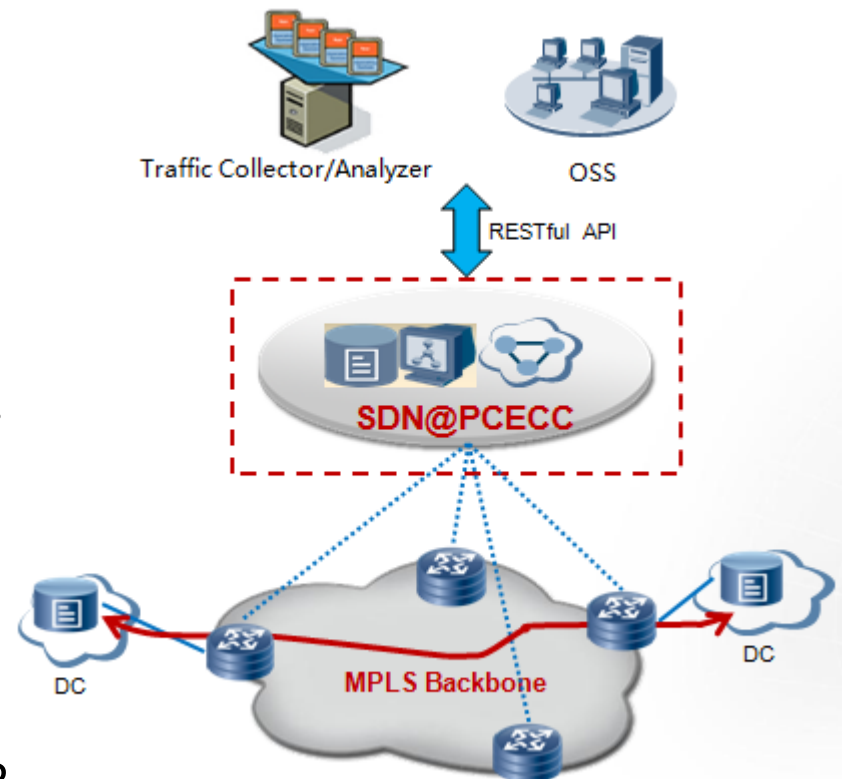

Use Case1 – PCECC Based LSP Setup/LFIB Downloading During the SDN Migration

- Keep the legacy nodes as they are;
- Initiated the LSP through PCECC and download the Label forwarding entry to the PCECC enabled nodes.

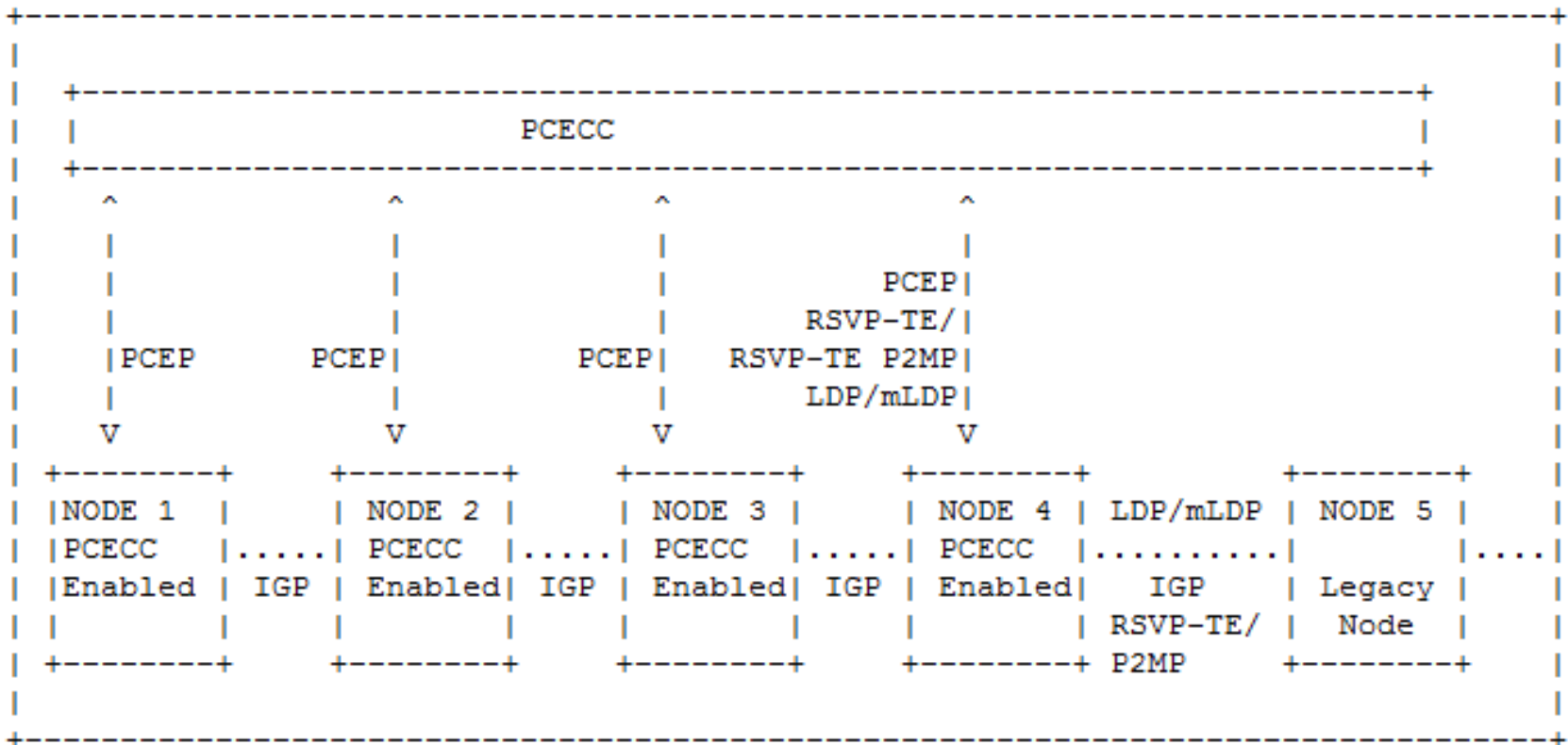

Use Case2 – MPLS Global Label Negotiation

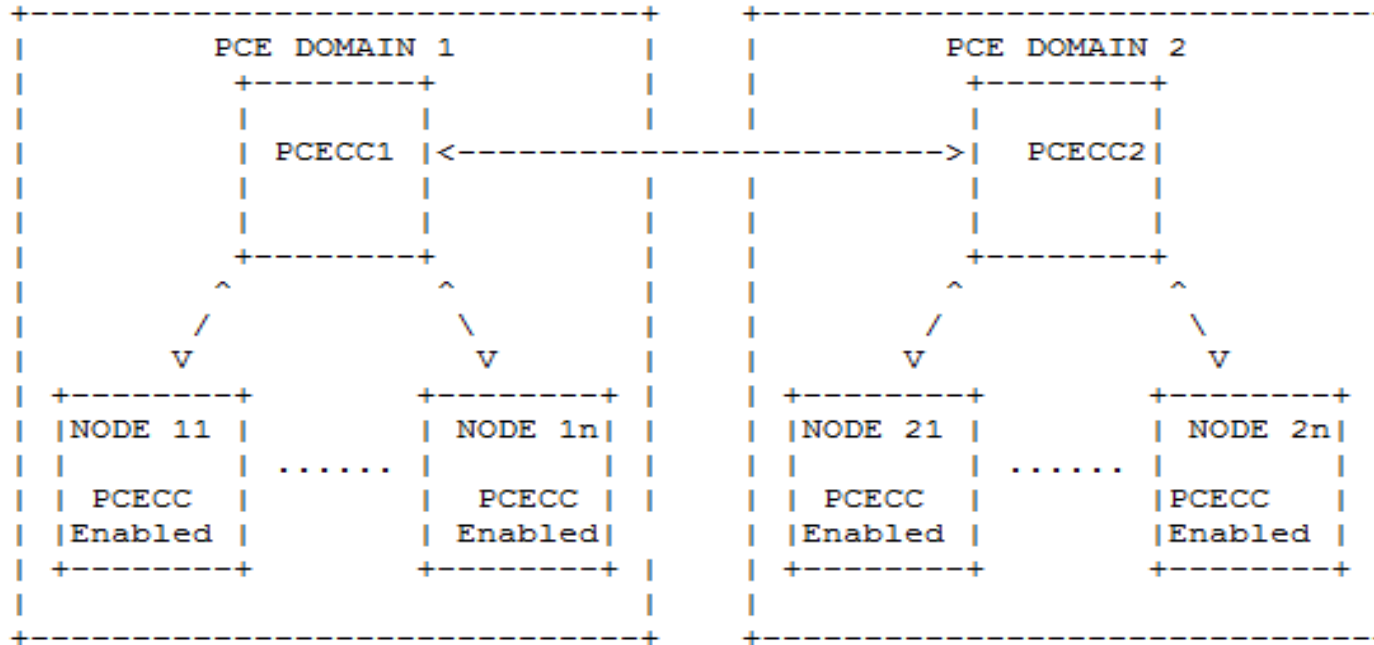

- [I-D.li-mpls-global-label-usecases] proposes possible use cases of MPLS global label. MPLS global label can be used to identify the location, the service and the network in different application scenarios.
- Using PCECC, the global label range can be dynamically negotiated among all the PCECC enables nodes.

Use Case3: Global View with Centralized Controller

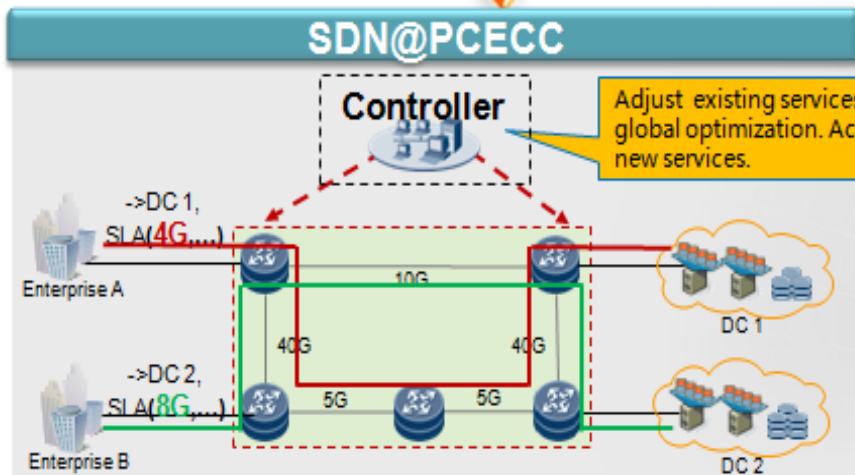
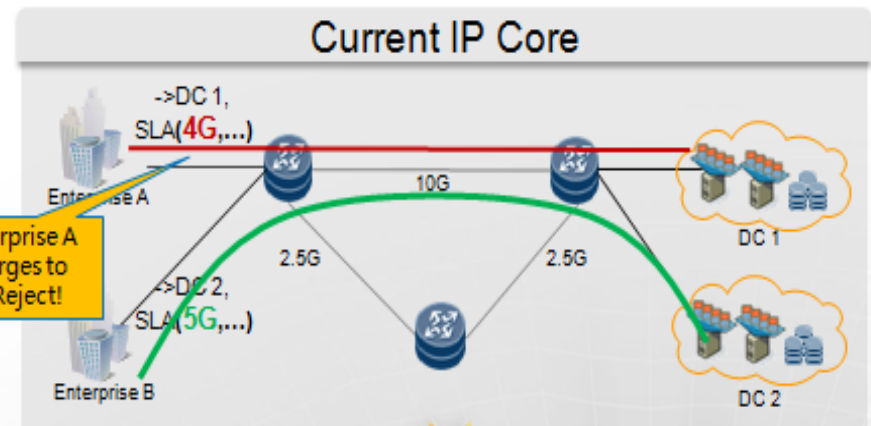
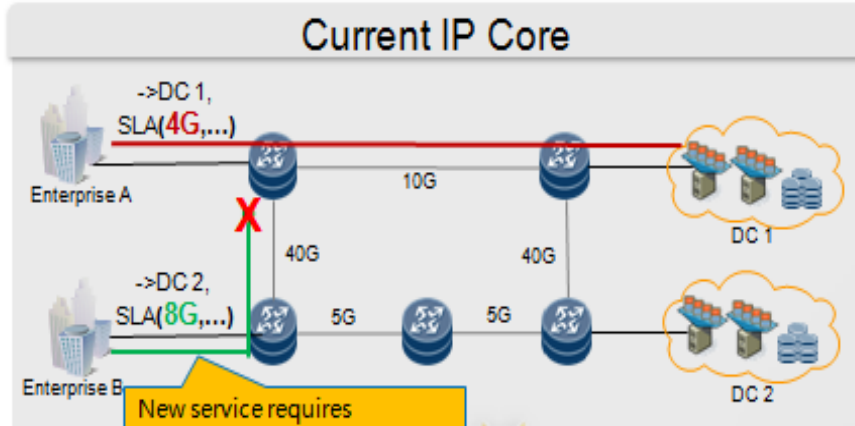

Provide Maximum Service Capacity by Resolving Resource Conflicts

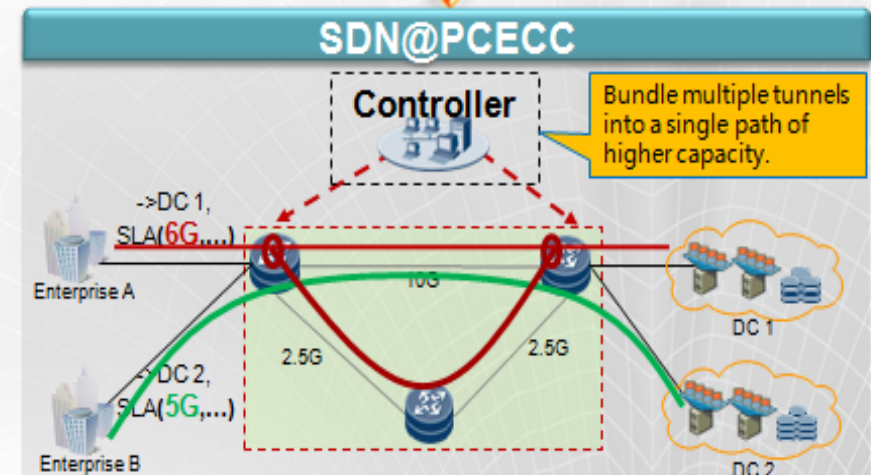

Maximize Network Utilization with Minimum Resource Fragmentation

Use Case4: Automatic & Dynamic Adjustment

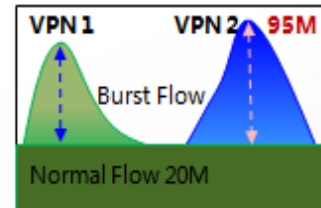
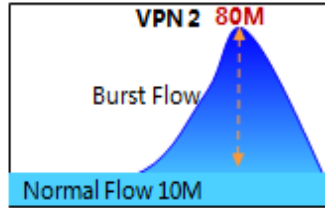
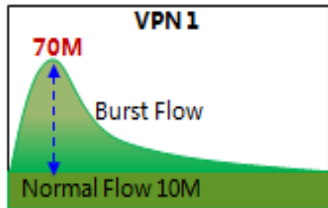

- ① Monitor Link Utilization and Real-time Tunnel Traffic
- ② Real-time Bandwidth Adjustment based on real traffic. Because of user traffic patterns and strong burst time distribution characteristics, dynamic bandwidth adjustment can improve link utilization, reduce the cost of network.

Current IP Core

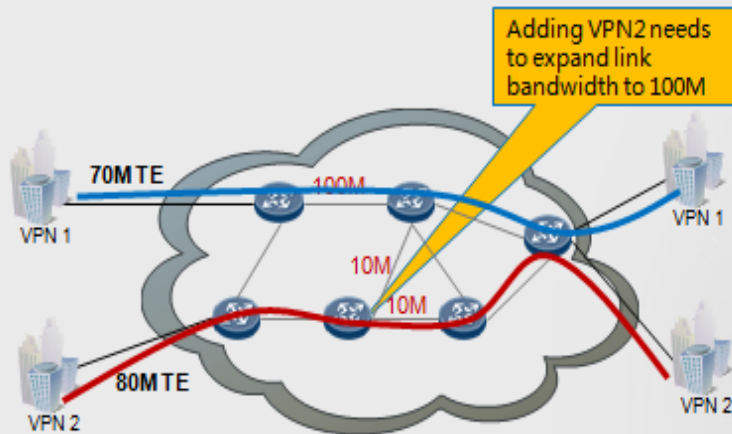

TE Is Based on Fixed and Peak Bandwidth Allocation. More of Transmission Resources Are Needed

SDN@PCECC

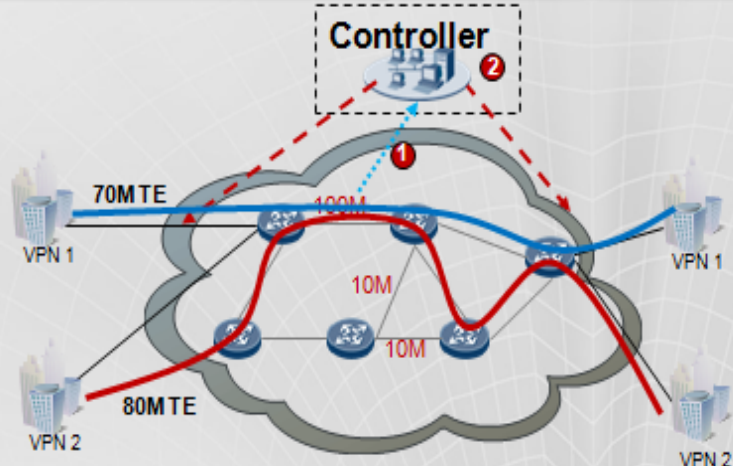

Allocate Bandwidth Based on Real-time Traffic. Improve Link Utilization. Reduce the Transport Cost.

Use Case5: Refinement Operation

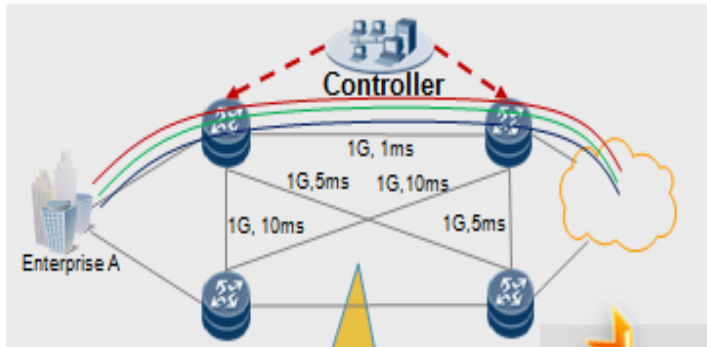

- VoD, Max 1G, 1ms
- VoIP, Max 1G, 5ms
- HSI, Max 1G, 10ms

Refined traffic scheduling can identify user traffic classes. According to the defined SLA, traffic flows of different classes are directed into tunnels of different qualities dynamically.

The initial flow rate is very small, totally not exceeding 1G. All services go through low latency links

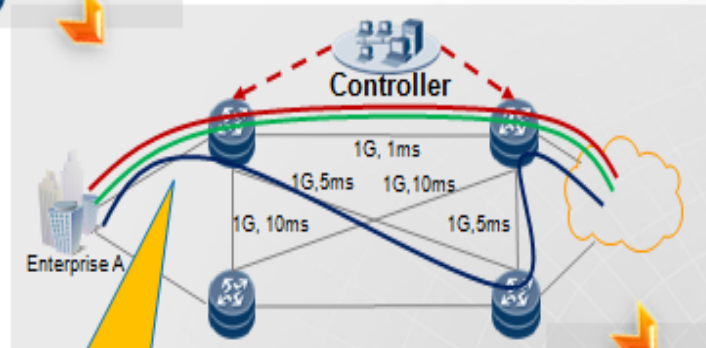

As traffic increases ($>1G, <2G$), HIS service is automatically directed into low latency links.

As traffic continuously increases ($>2G, <3G$), different SLA services are directed into links of corresponding latencies.

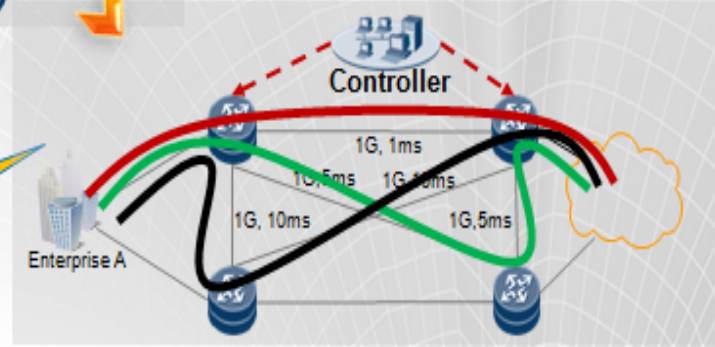

Bits n Bites etc.

➤ At tomorrow's Bits n Bites meeting there will be a implementation demo session for the PCECC . You are welcome to visit us and give your comments and suggestions.

Next Steps

- More use cases will be added in the future version.
- Solicit more comments and feedback.
- Revise the draft.

Thanks