

# UNI Extensions for Diversity and Latency Support

draft-fedyk-ccamp-uni-extensions-04

## IETF 89 – CCAMP WG

Don Fedyk	<a href="mailto:Don.Fedyk@hp.com">Don.Fedyk@hp.com</a>
Dieter Beller	<a href="mailto:Dieter.Beller@alcatel-lucent.com">Dieter.Beller@alcatel-lucent.com</a>
Lieven Levrau	<a href="mailto:Lieven.Levrau@alcatel-lucent.com">Lieven.Levrau@alcatel-lucent.com</a>
Daniele Ceccerelli	<a href="mailto:Daniele.Ceccarelli@ericsson.com">Daniele.Ceccarelli@ericsson.com</a>
Fatai Zhang	<a href="mailto:ZhangFatai@huawei.com">ZhangFatai@huawei.com</a>
Yuji Tochio	<a href="mailto:Tochio@jp.fujitsu.com">Tochio@jp.fujitsu.com</a>
Xihua Fu	<a href="mailto:Fu.Xihua@zte.com.cn">Fu.Xihua@zte.com.cn</a>

# Agenda

- Updates from 03 to 04 version
  - New section dealing with diversity aspects in a multi-domain environment where some domains are utilizing a PCE.
- Operational procedure details
- Next steps

# Updates from 02 to 03 version

- Diversity part for dual-homed CEs:
  - New section on compatibility with PCE added:
    - Compatibility of domains using distributed routing and path computation with domains using the centralized PCE approach
    - Solution for PCE domains is based on [draft-zhang-ccamp-route-exclusion-pathkey-01.txt](#)
- Latency part:
  - No updates
- Draft fairly stable

# Operational procedure details

- Combined solution where signaling and constraint-based path computation is involved:
  - Signaling:
    - Carrying diversity constraints for the LSP being established (to ensure that the LSP is diverse w.r.t. another LSP)
    - Collecting diversity information for the LSP that can be passed on for establishing a diverse routed LSP (SRLG Lists or “cookies”)
  - Path computation:
    - Done locally at the ingress node of a domain
    - Done by a centralized PCE (ingress node sends a PCEP request to the PCE)
    - Diversity constraints are provided explicitly (list of SRLG IDs) or indirectly in form of a key (PAS or path key in case of PCE)
    - Constraints are taken into account when a path is calculated from ingress to egress of the domain

# Single domain diversity use case

## Distributed routing and path comp.

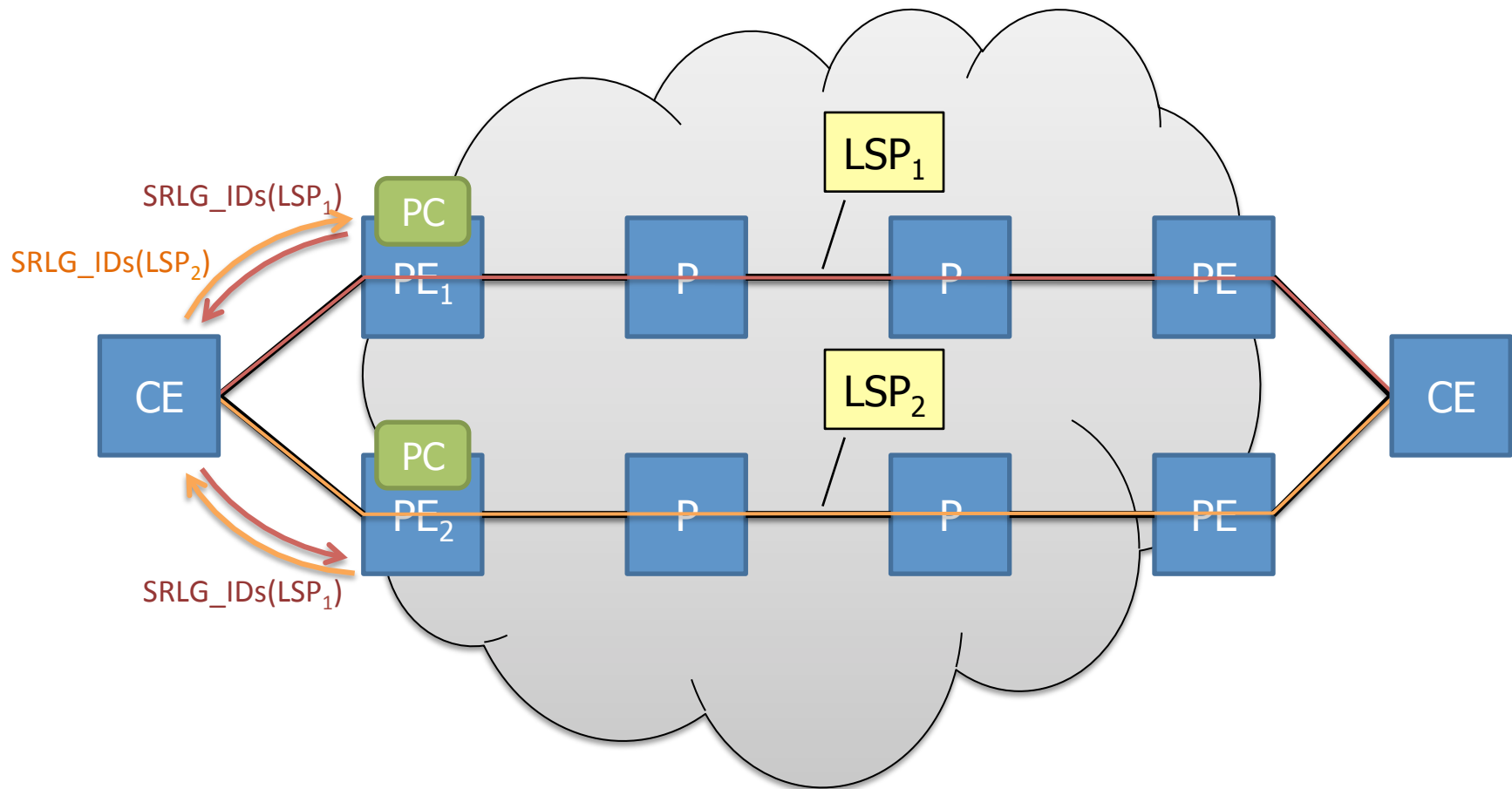

Exchange of SRLG ID list for disjoint LSPs via source CE node

# Single domain diversity use case

## Domain with a PCE

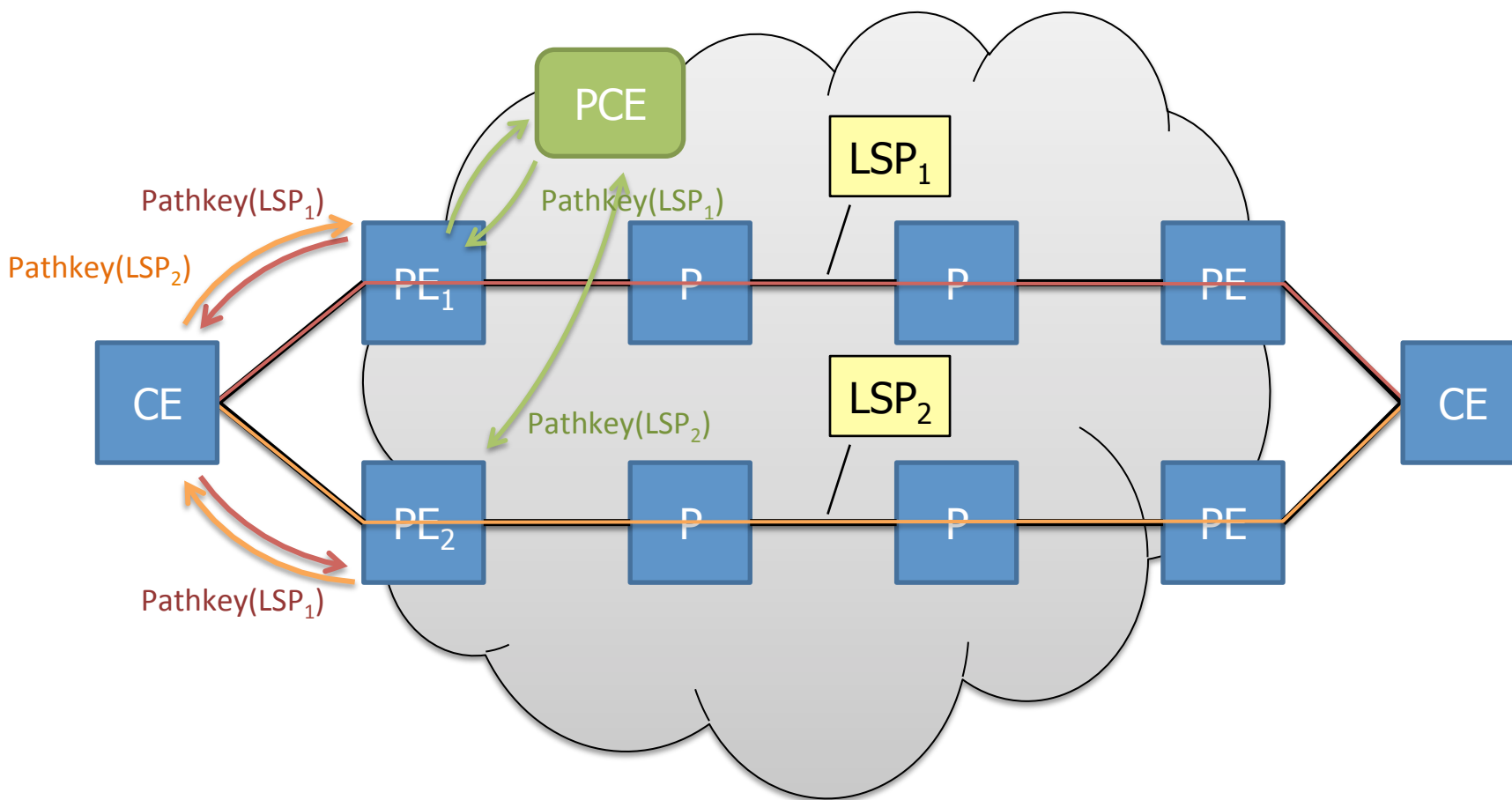

Exchange of Pathkey for disjoint LSPs via source CE node

# Mixed multi-domain diversity use case

## Diversity information scoped to domains

$Div\_Info(LSP_1) = [domain\_SO(D_A), SRLG\_IDs(D_A)],$   
 $[domain\_SO(D_B), Pathkey\_SO(D_B)],$   
 $[domain\_SO(D_D), PAS\_SO(D_B)]$

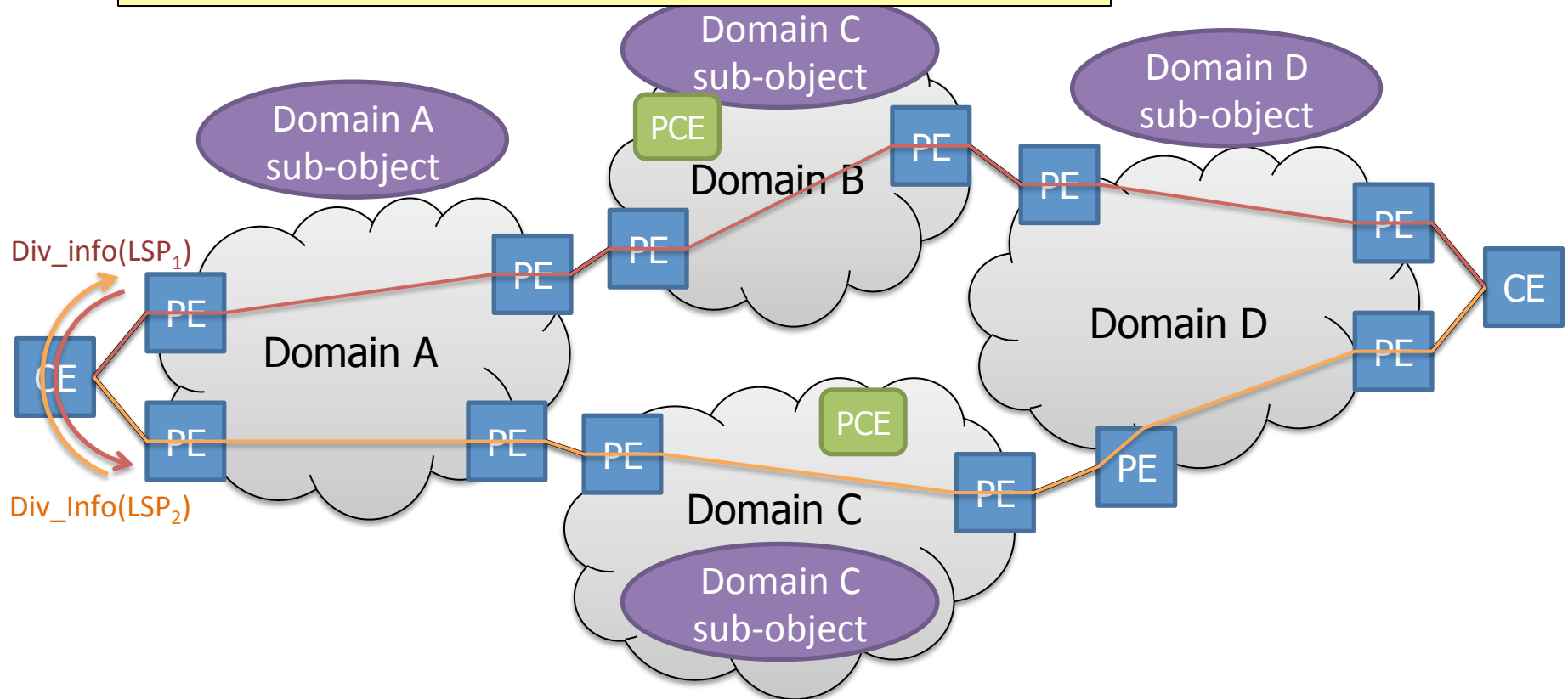

# Next Steps

- Solicit feedback/comments from the group
- Work with authors of the related diversity drafts trying to come up with a single solution applicable to all use cases/scenarios.
- WG adoption not intended right now due to the previous point.
- Ensure that the overlay framework draft includes the use cases for which this drafts describes solutions.



# Thank You!