

Inter-AS Option B between NVO3 and BGP/ MPLS IP VPN network

draft-hao-l3vpn-inter-nvo3-vpn-00

Weiguo Hao(Huawei)

haoweiguo@huawei.com

Lucy Yong(Huawei)

lucy.yong@huawei.com

Susan Hares(Huawei)

shares@ndzh.com

July, 2014 Toronto Canada

Scenario

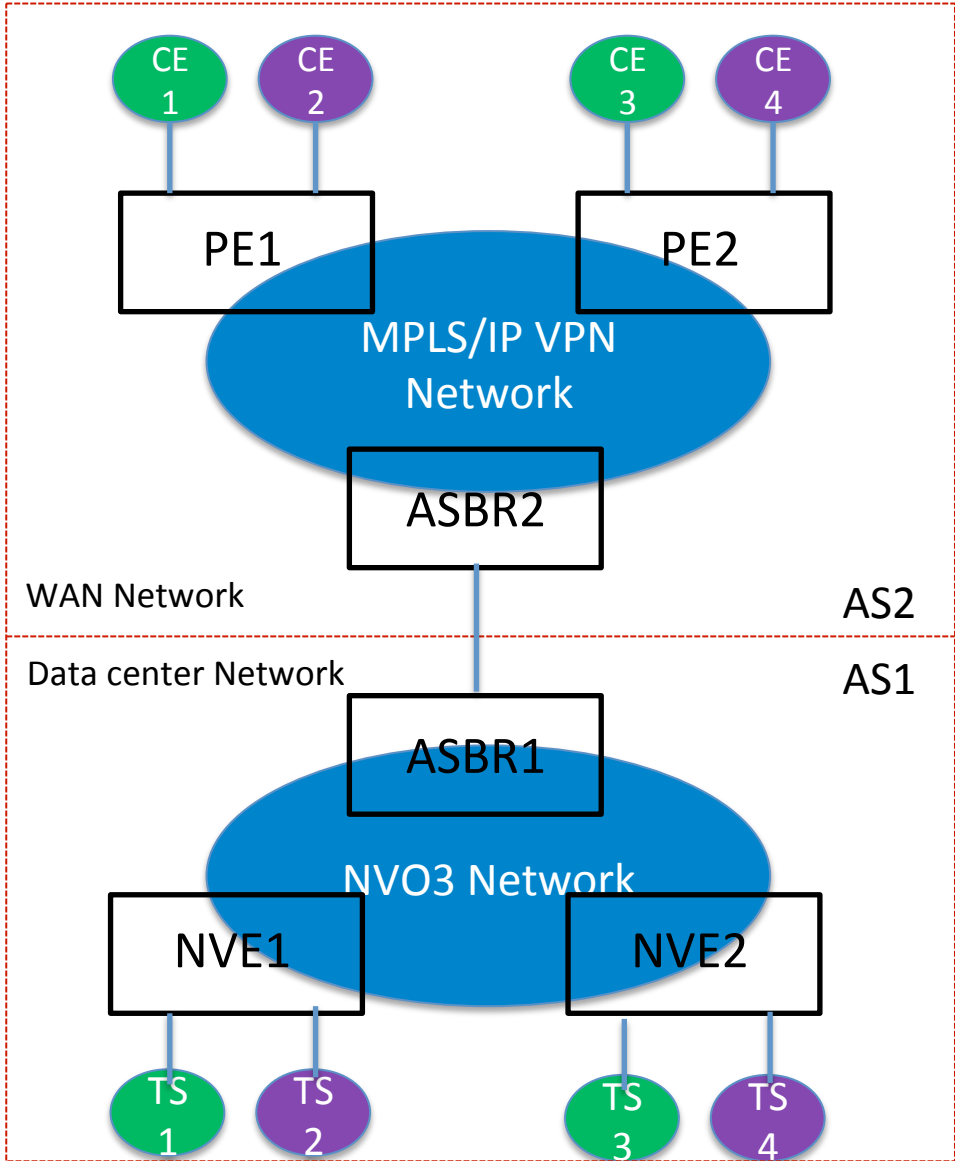

Inter-as connection should be setup between ASBRs.
Two solutions:
1. Option-A
2. Option-B.

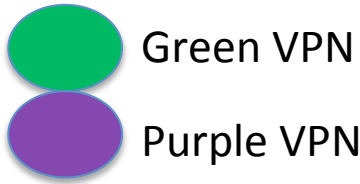

Option-A solution

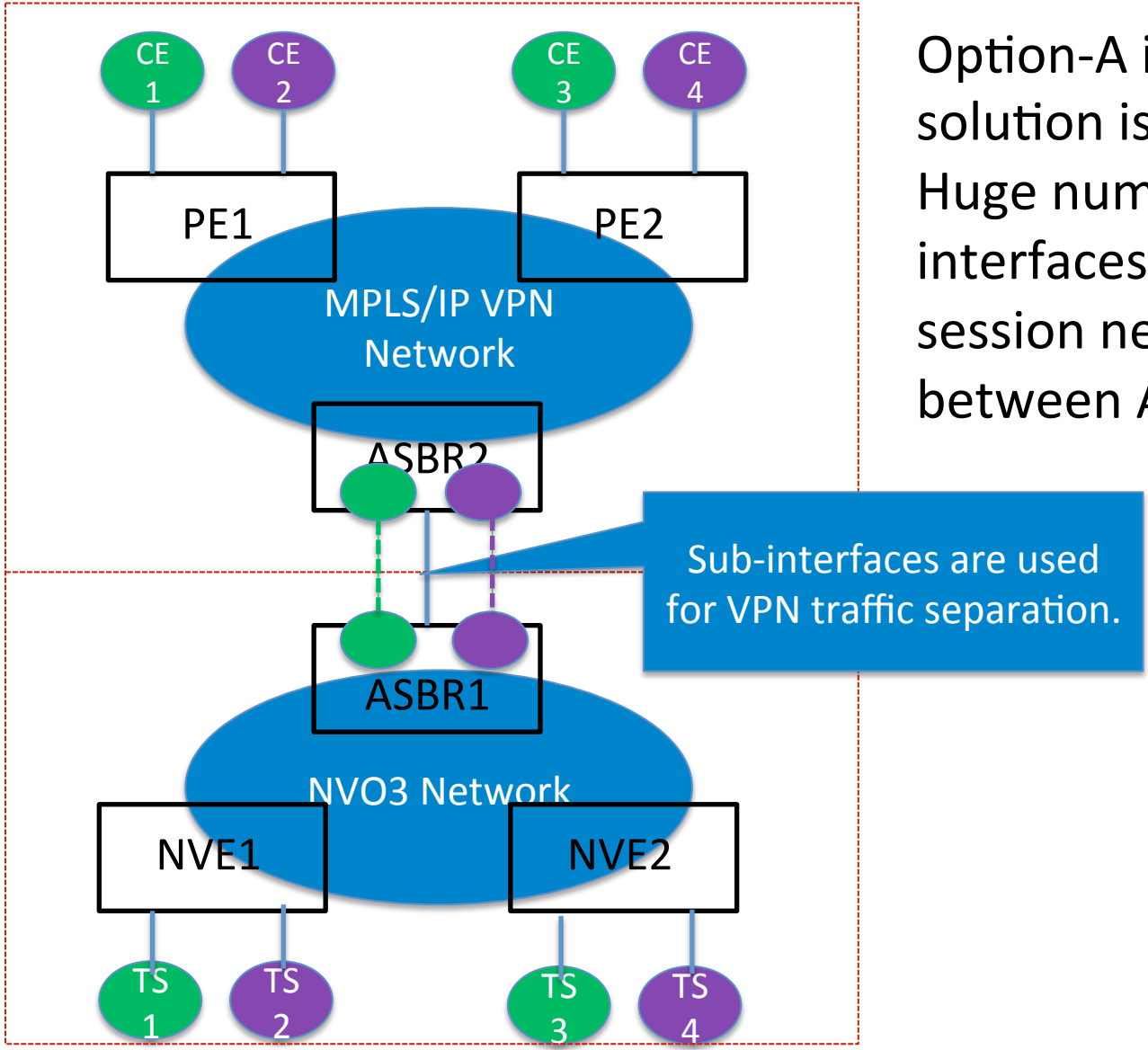

Option-A inter-as solution issues:
Huge number of sub-interfaces and EBGP session need to exist between ASBRs.

Option-B solution: outgoing direction

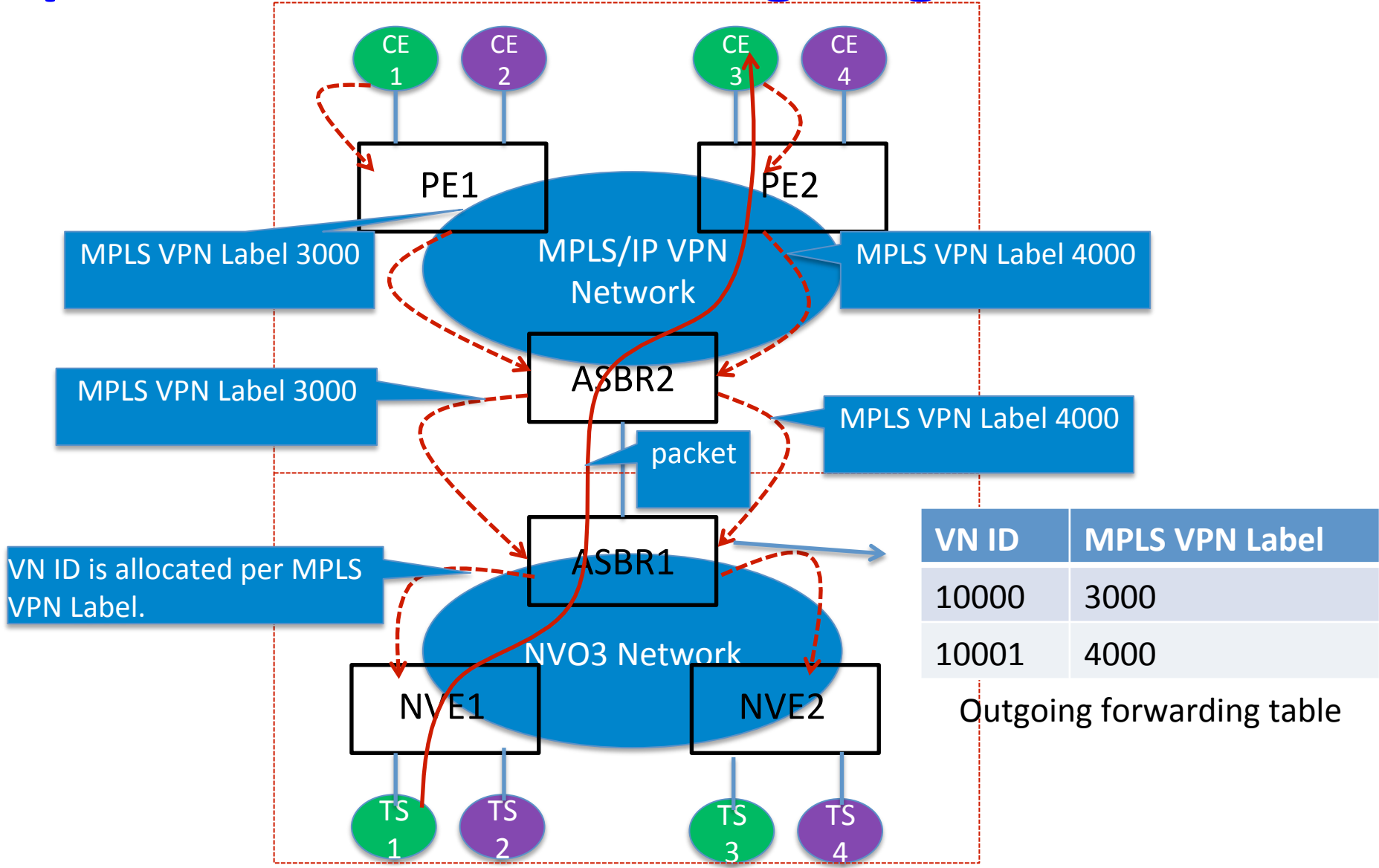

VN ID	MPLS VPN Label
10000	3000
10001	4000

Outgoing forwarding table

Option-B solution: incoming direction

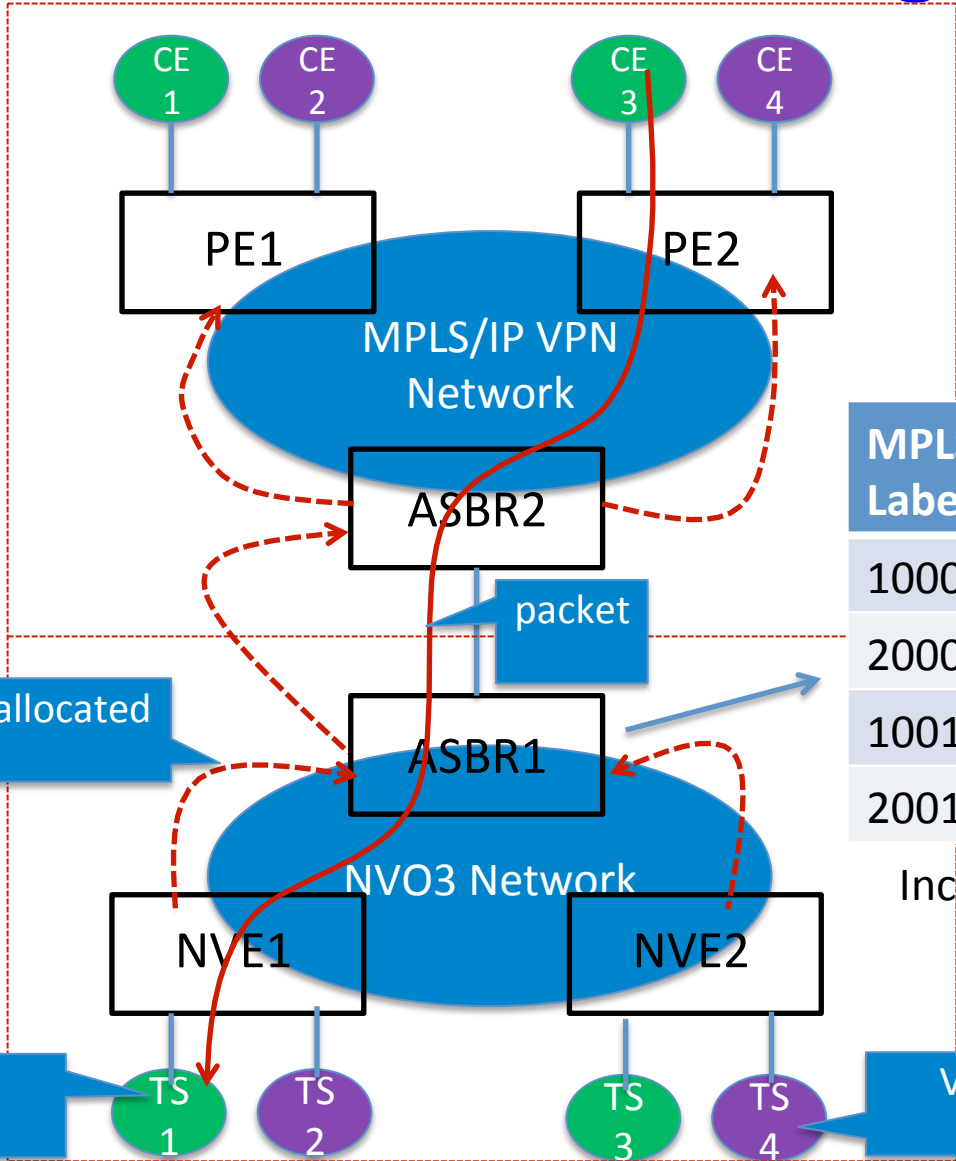

MPLS VPN Label is allocated per VN per NVE

MPLS VPN Label	NVE+VN ID
1000	NVE1 +10
2000	NVE1+20
1001	NVE1 +10
2001	NVE2+20

Incoming forwarding table

Vanilla Option-B solution characteristics

- No VRF exists on ASBR
- No sub-interface associated with each VRF exists between ASBRs
- No EBGP session associated with each VRF exists between ASBRs
- Only VN ID and MPLS Label switching on ASBR

Comments from Robert

- ASBR for some VPNs can be just pure vanilla option B and for those which have a lot of prefixes can be enhanced with per VRF aggregation function. Robert's solution can reduce routing fluctuations in NVO3 network . In WAN to DC direction , VPN option-B connection terminates on ASBR-1 in Robert's solution. In this draft, VPN option-B connection extends to local NVE in data center.
- Define few modes of VN_ID allocations on ASBR1.
- The above points will be adopted in next version.

Next Steps

- Solicit other comments and suggestions.