

# Motivation

- Deterministic 4over6 mechanisms require coupling IPv4 and IPv6 addresses
  - A Softwire has to be sourced from a specific IPv6 address
  - Addresses are pre-allocated (blocked out) for clients
  - Results are address wastage and lack of flexibility
- This proposal signals the client's v4-v6 binding source IPv6 address to server
  - Enables the dynamic set up of softwires v4/v6 bindings
  - Flexible source v6 address choice
    - Any routable v6 address is OK
  - Uses a new DHCPv6 container to group options
    - A sign of using DHCPv4 over DHCPv6 for client provisioning

# DHCP 4o6 Softwire Container

- DHCPv6 options
- MUST be used within the DHCPv4-query/response messages
  - Enable DHCP 4o6 first
- Contents in the container is bound to the DHCPv4 messages
- Hint option is optional
  - Client: LPM to select a prefix
- Src Addr option MUST contain a /128 v6 addr

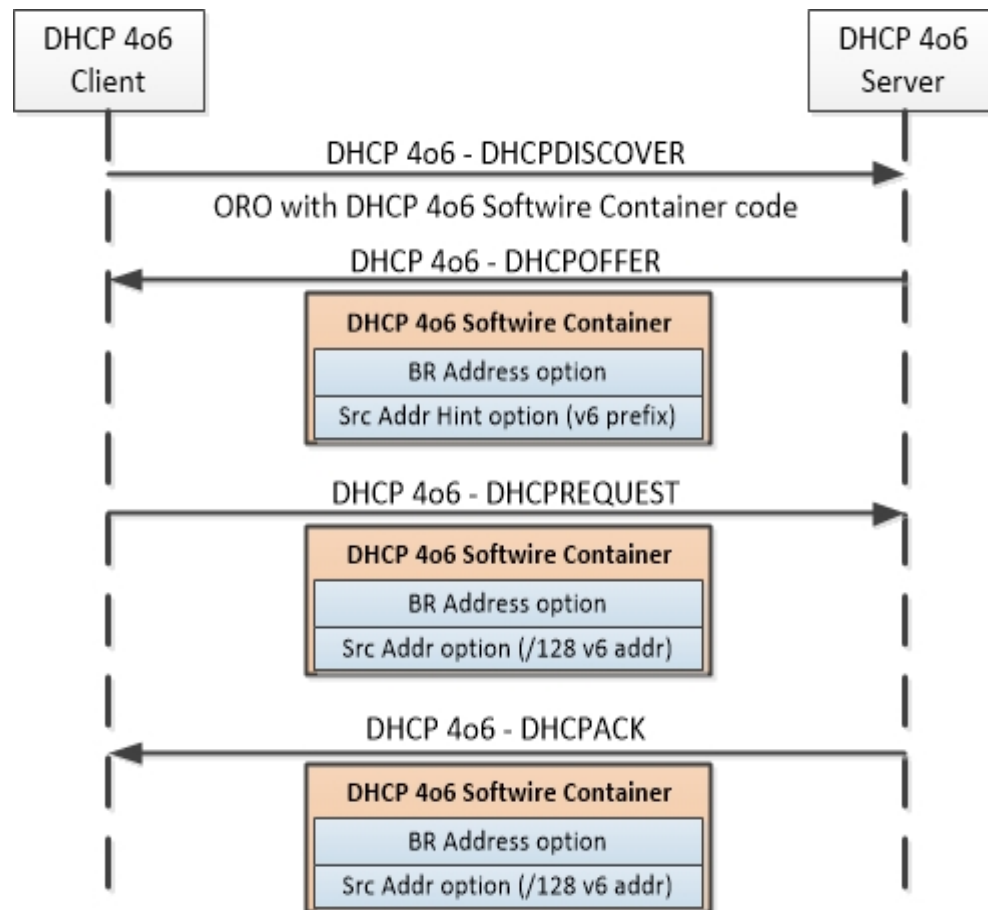

# DHCP 4o6 Softwire Container Format

- Similar to containers in the map-dhcp document
    - Grouping relevant options
  - Re-use S46 BR option defined in map-dhcp
- ⇒ Nothing new: using agreed approach to provision softwire

# IPv6 Source Address Changing

- DHCPv4 over DHCPv6 relies on IPv6 configuration
  - IPv6 source address changing causes DHCP 4o6 re-enable
  - When IPv4 renews/rebinds
    - Include this container along with DHCPREQUEST
- Lw4o6 base requires lwB4's dynamic provisioning re-initiated if IPv6 configuration changes

# Next step

- It's necessary to provide enough information to run dynamic 4over6 software mechanisms
- Comments?
- Adoption?