

6rd Multicast

draft-zhou-softwire-6rdmulticast-01

Cathy Zhou <cathy.zhou@huawei.com>

Behcet Sarikaya <sarikaya@ieee.org>

Tina Tsou <Tina.Tsou.Zouting@huawei.com>

Hui Ji <jihui@chinatelecom.com.cn>

Summary

- Two basic approaches
 - Encapsulation approach routes signalling and data through the 6rd tunnel
 - Translation approach uses native IPv4 multicast capability in the access network, requires interworking of signalling

Encapsulation Approach

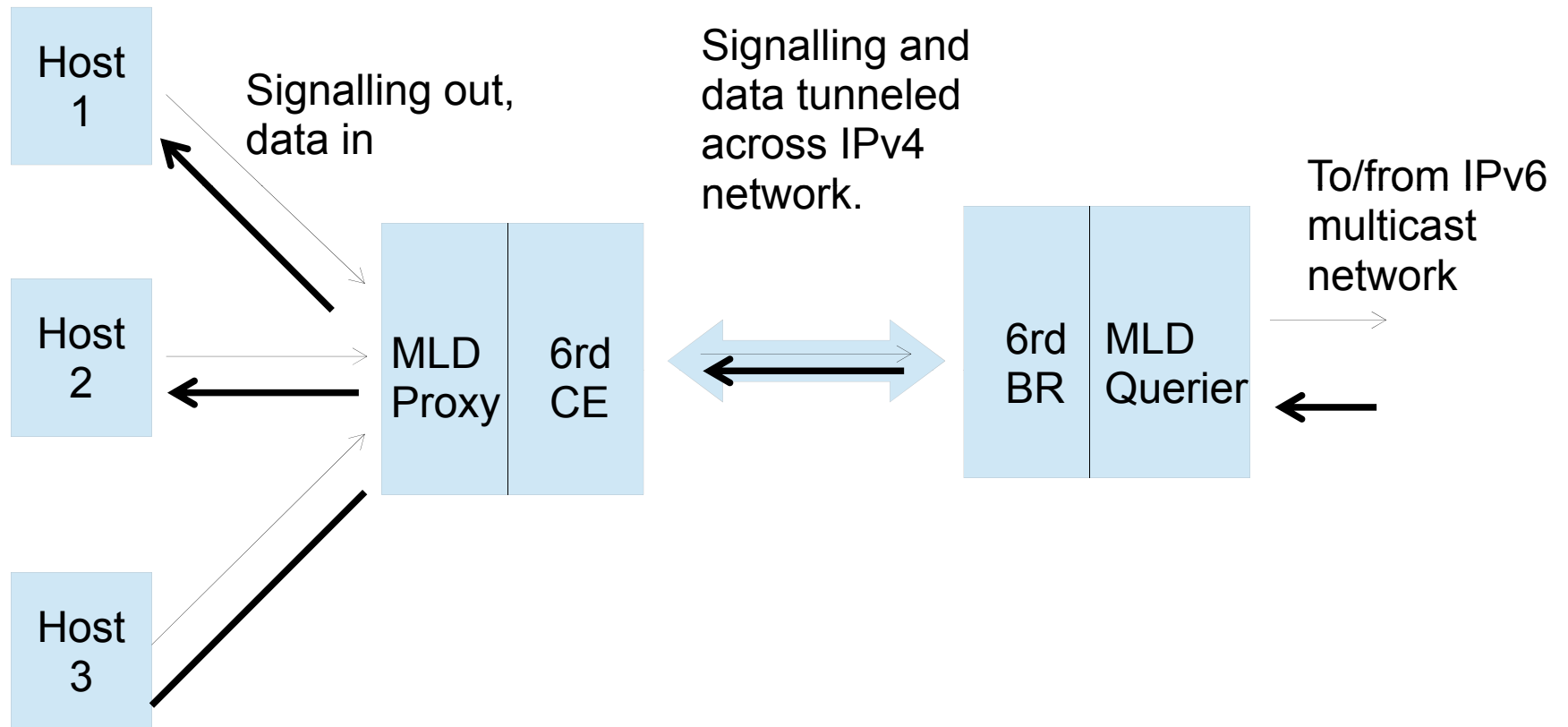

Translation Approach

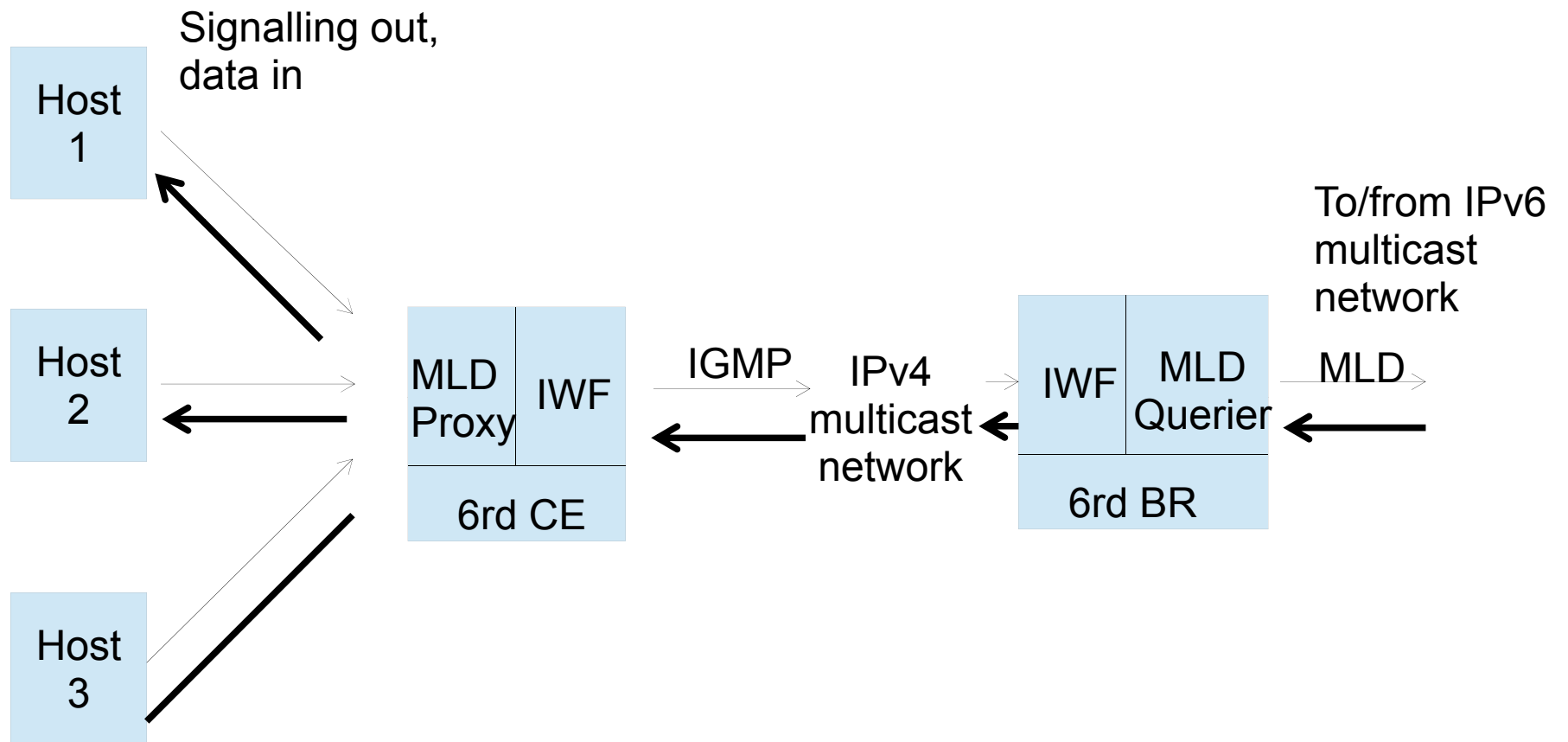

Moving Forward

- Does WG agree with encapsulation approach?
- Does WG agree with translation approach?
- WG work item(s)?