



Recursive Internet Architecture EC-Funded projects

IRATI, GN3+ OC.IRINA and PRISTINE

Dimitri Staessens – Ghent Uni. iMinds (BE)

Current challenges

- explosion in the complexity of the overall system (hundreds of protocols and thousands of standards documents)
- security
- scalability issues with the routing system
 - (IPv6/BGP multihoming)
 - Mobile end-users
- Application mobility

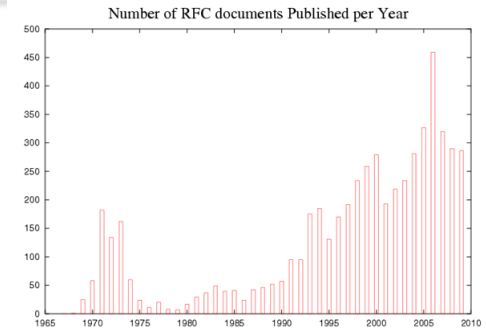

Prefixes announced on the Internet

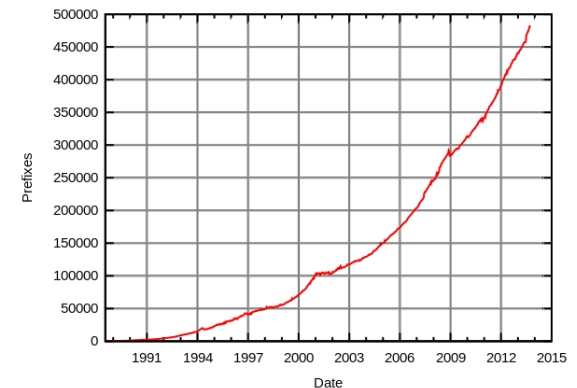

Production environment

- ever growing customer base
- ever growing number of devices
- new and more demanding services
- “worse is better”
- RAD of services
- fast deployment

Human Beings vs, Internet Connected Devices (millions)

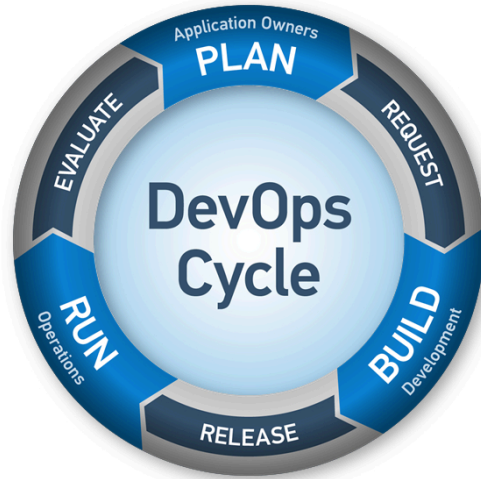
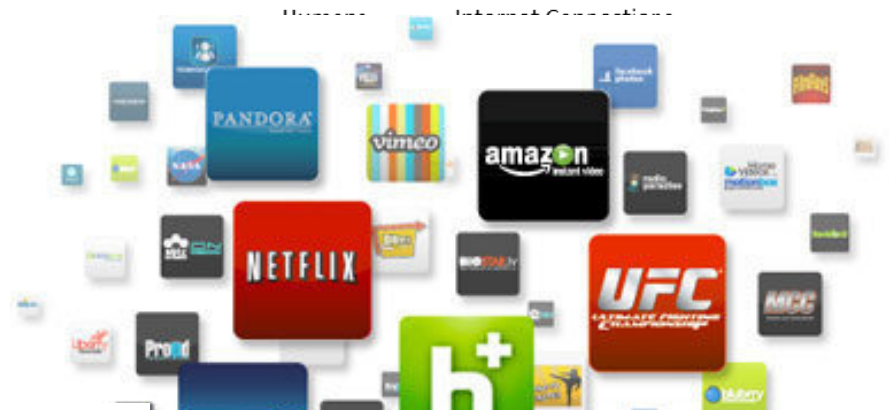
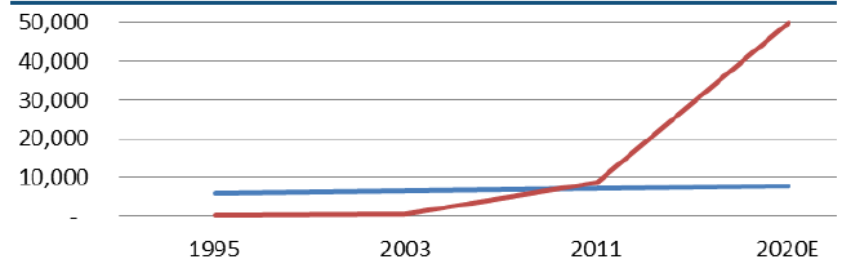

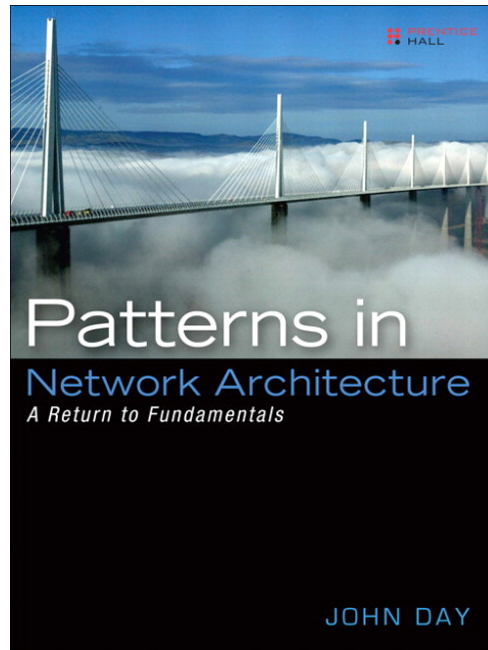

A brief introduction to the Recursive Internet Architecture

RINA

Extending the IPC model

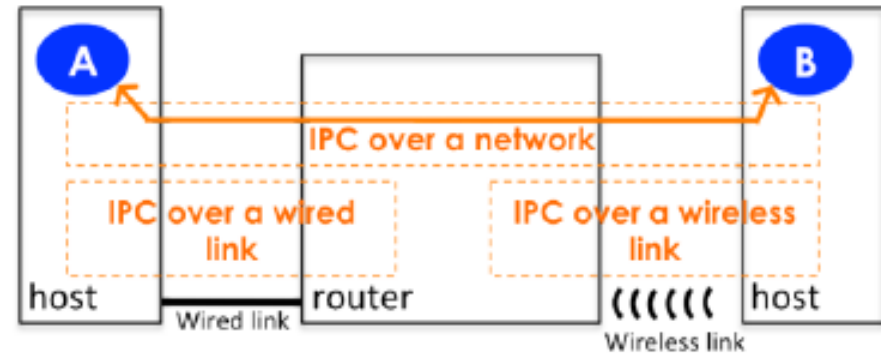
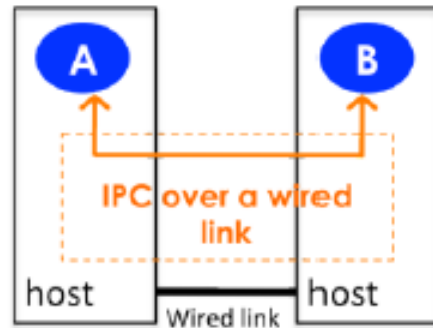
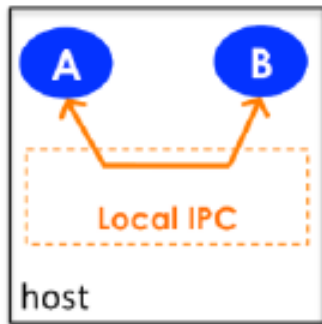

Providing IPC services (with different characteristics) over different scopes

Everyday
practice

RINA

Theory

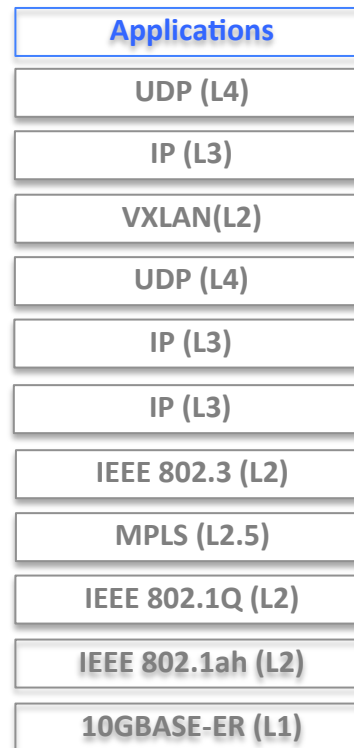
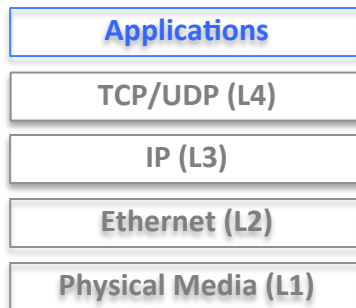

- APs communicate using a port, identified by a portId
- 6 operations:
 - int **_registerApp**(appName, List<difName>)
 - portId **_allocateFlow**(destAppName, List<QoSParams>)
 - int **_write**(portId, sdu)
 - sdu **_read**(portId)
 - int **_deallocate**(portId)
 - int **_unregisterApp**(appName, List<difName>)
- QoSParams are defined in a technology-agnostic way
 - Bandwidth-related, delay, jitter, in-order-delivery, loss rates, ...

Distributed Applications Provide IPC services

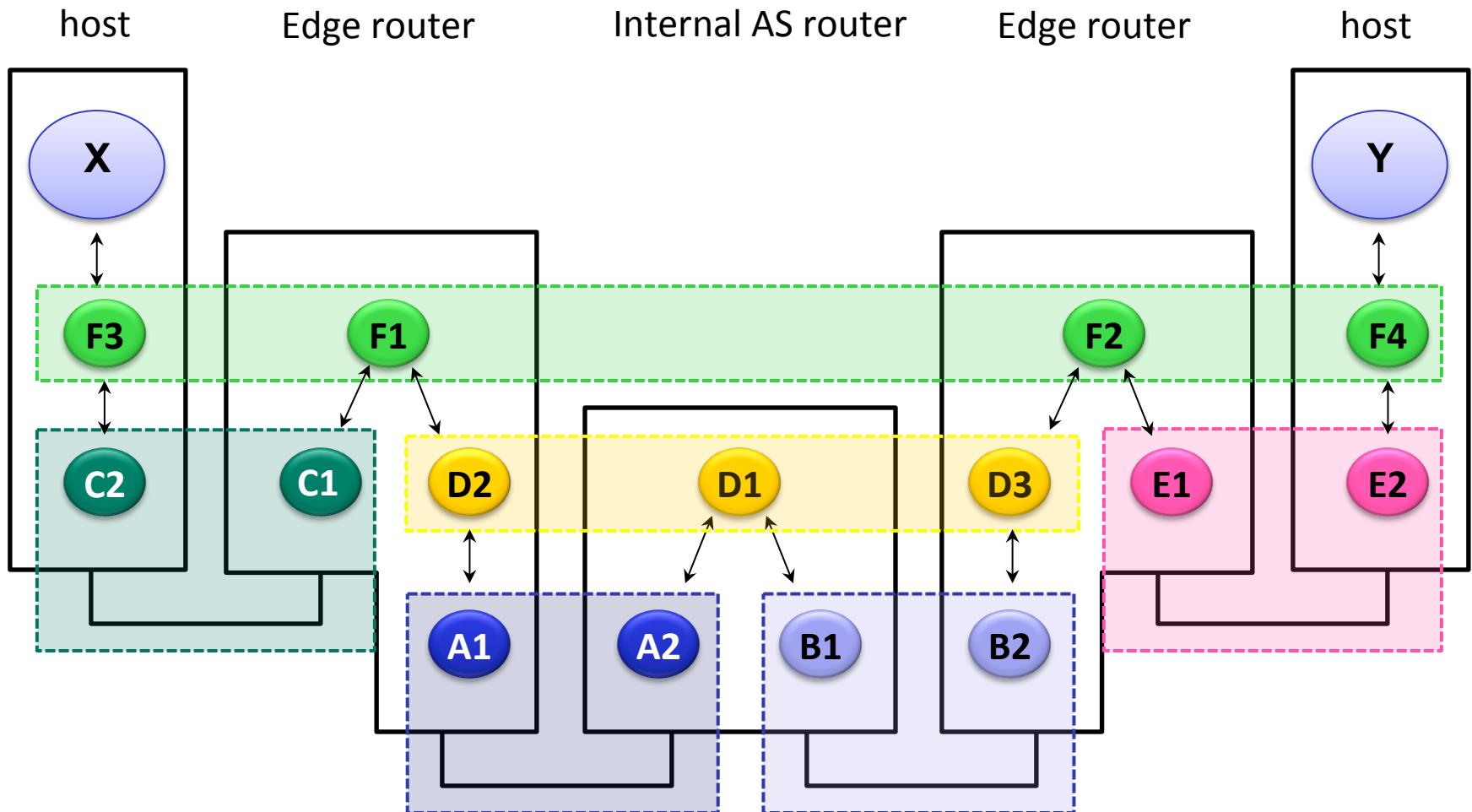

Architectural Model

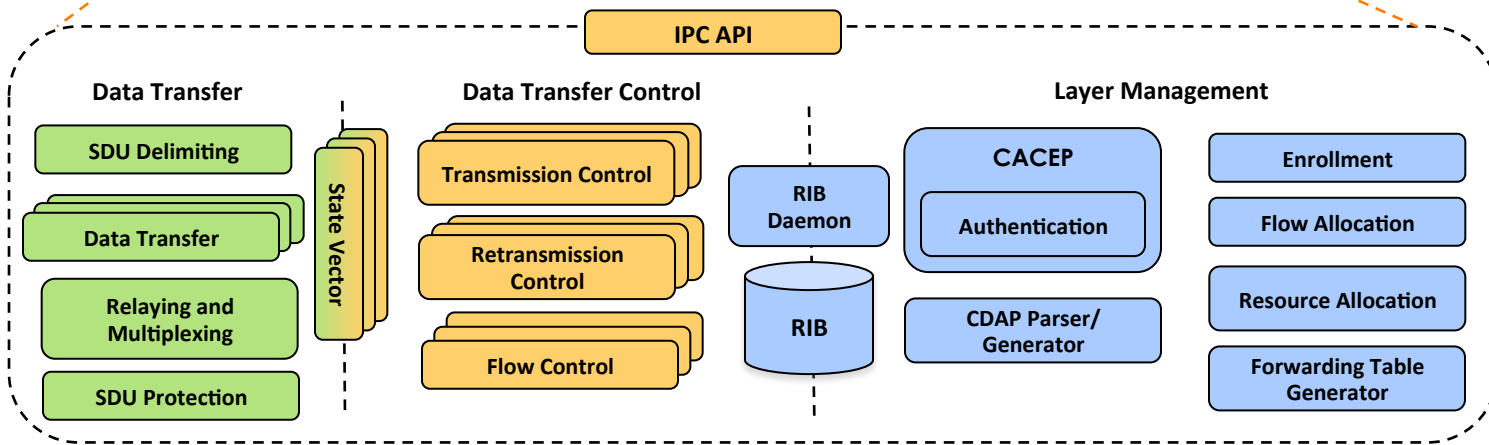
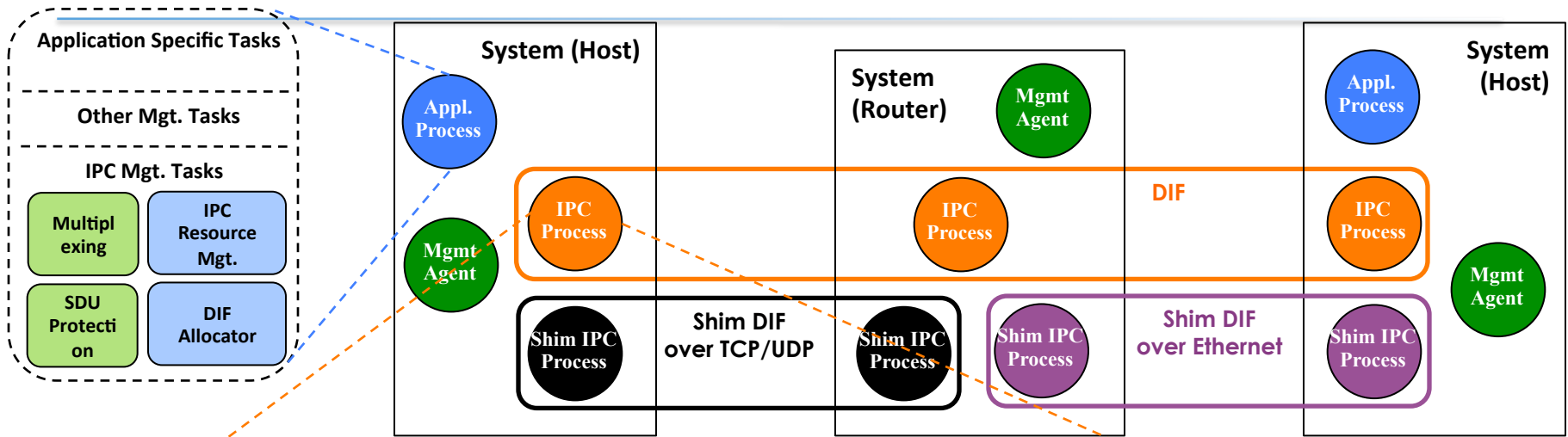

Increasing timescale (functions performed less often) and complexity

FP7 IRATI – OVERVIEW

IRATI - Introduction

- FP7 Project – **Jan 2013** to **Dec 2014** (2 years)
- 5 partners
 - [**Research**] Fundació Privada i2CAT (Spain)
 - [**Research**] iMinds VZW (Belgium)
 - [**SME**] Nextworks s.r.l. (Italy)
 - [**Industry**] Interoute (UK/Italy)
 - [**Academia**] Boston University (US)



- **Validation of RINA concepts**
- **FOSS implementation of core functionalities**
 - IPC Process / IPC Manager daemons
 - Transport and management tasks
- **Stack publicly available on GitHub ~ 11/2014**

IRATI OS/Linux implementation

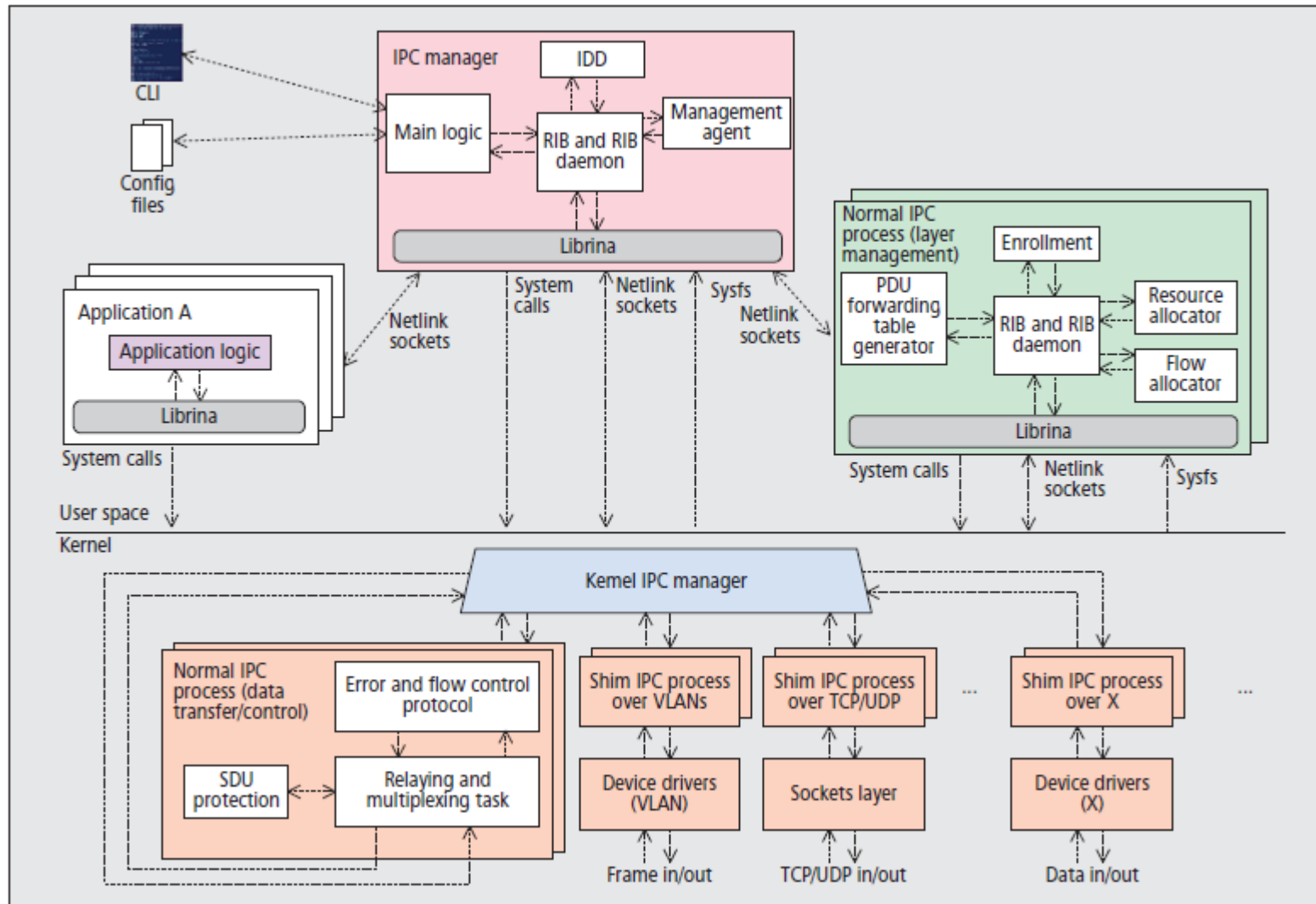

Source: S. Vrijders, F. Salvestrini, E.Grasa, M. Tarzan, L. Bergesio, D. Staessens, D. Colle
 " Prototyping [RINA], the IRATI project approach", IEEE Network, March 2014

IRATI Prototype initial tests

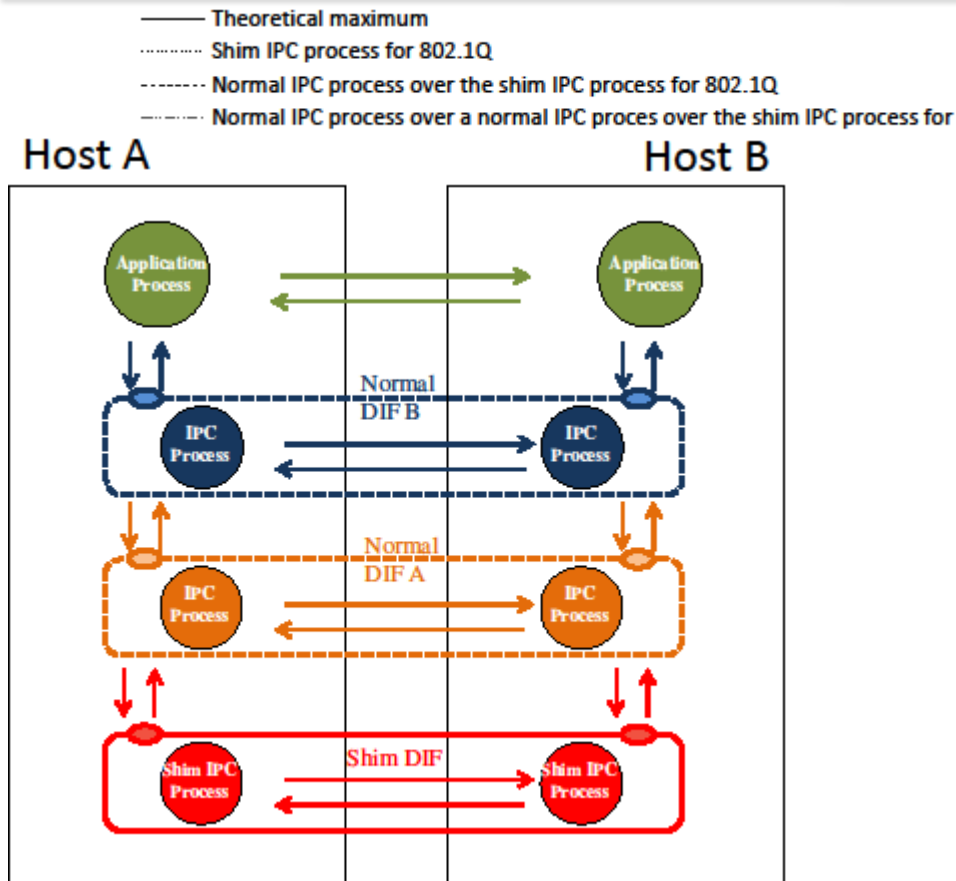

Source: S. Vrijders et al.
 "Experimental evaluation of RINA Prototype",
 IEEE Globecom, Dec 2014

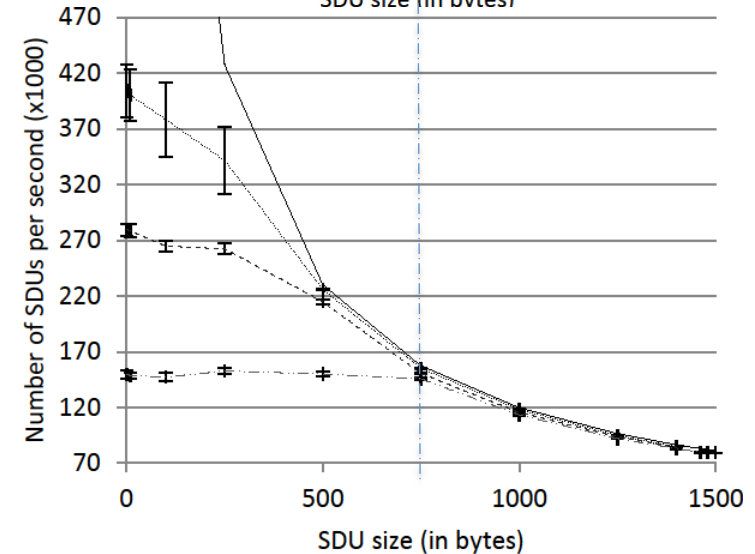
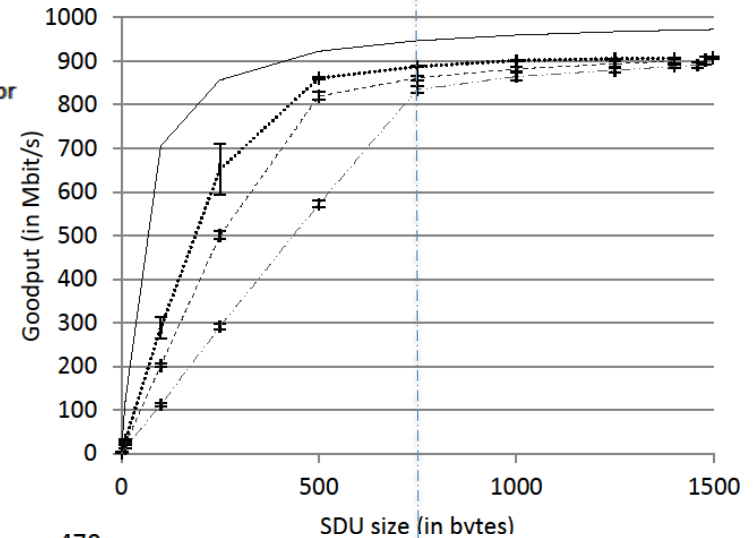

Link-state routing test (IS-IS based)

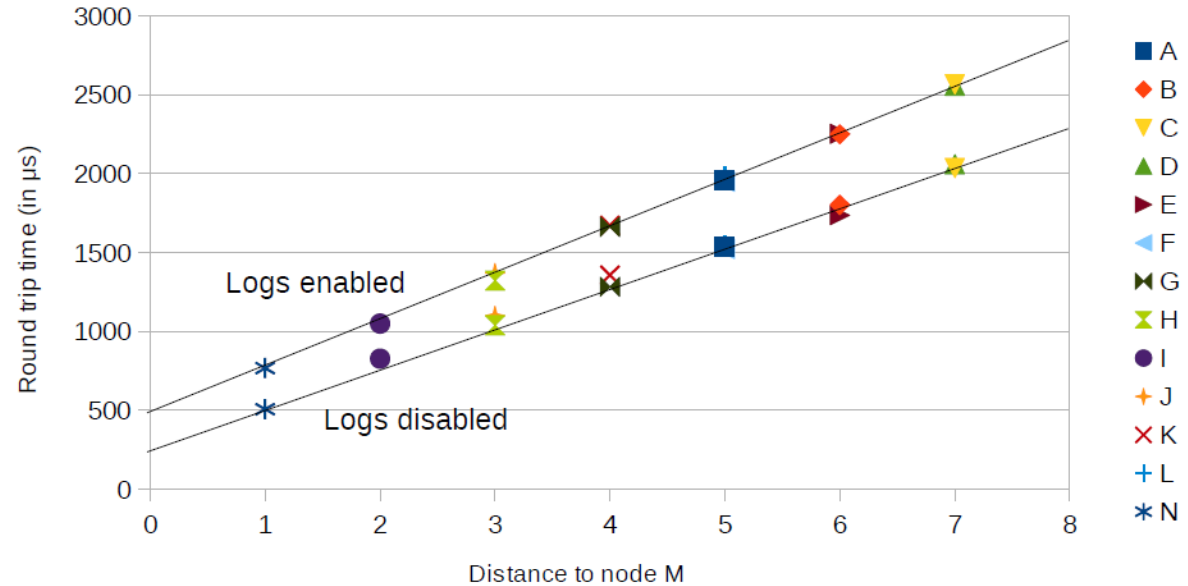
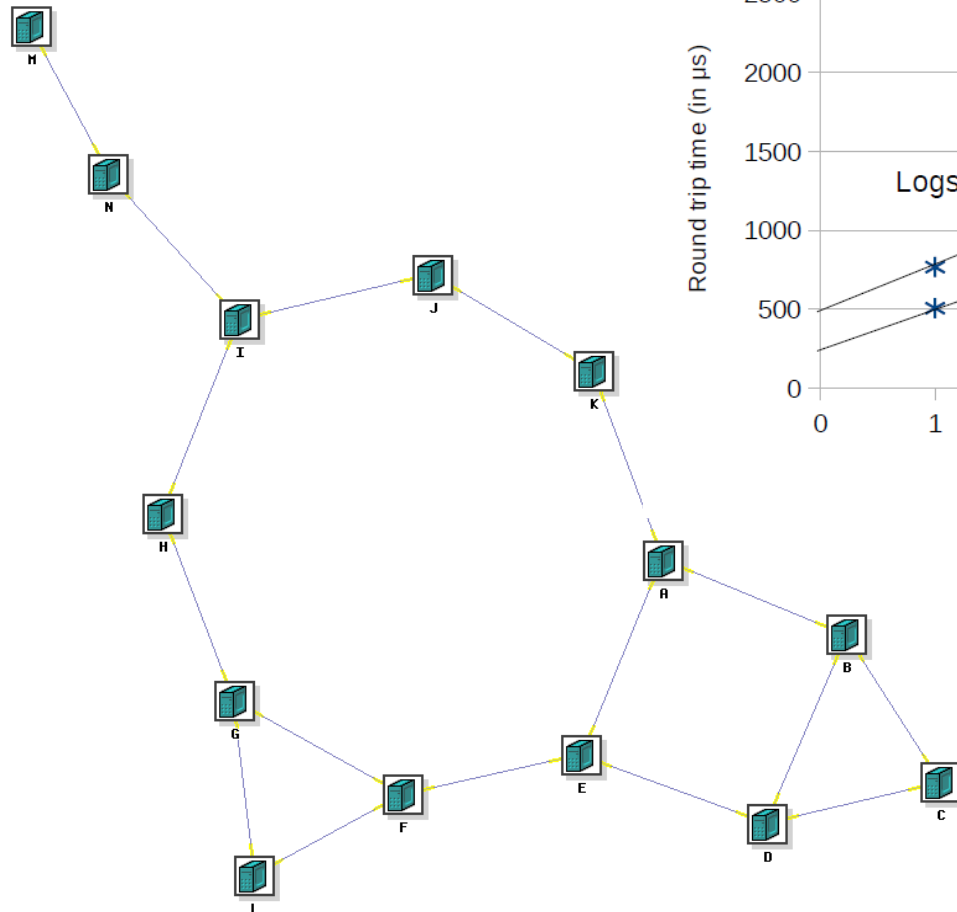

GEANT3+ IRINA – OVERVIEW

IRINA - Intro

- Investigating **RINA** as the next generation GEANT and **NREN** network **architecture** (IRINA)
- GEANT3+ project
 - Starts **Oct 2013**, ends **March 2015** (18 months)
- 4 Partners:
 - [**Research**] iMinds VZW (Belgium)
 - [**Research**] Fundació Privada i2CAT (Spain)
 - [**Research**] Waterford Institute of Technology – Telecommunications Software & Systems Group (Ireland)
 - [**SME**] Nextworks s.r.l. (Italy)

IRINA – Overview/Objectives

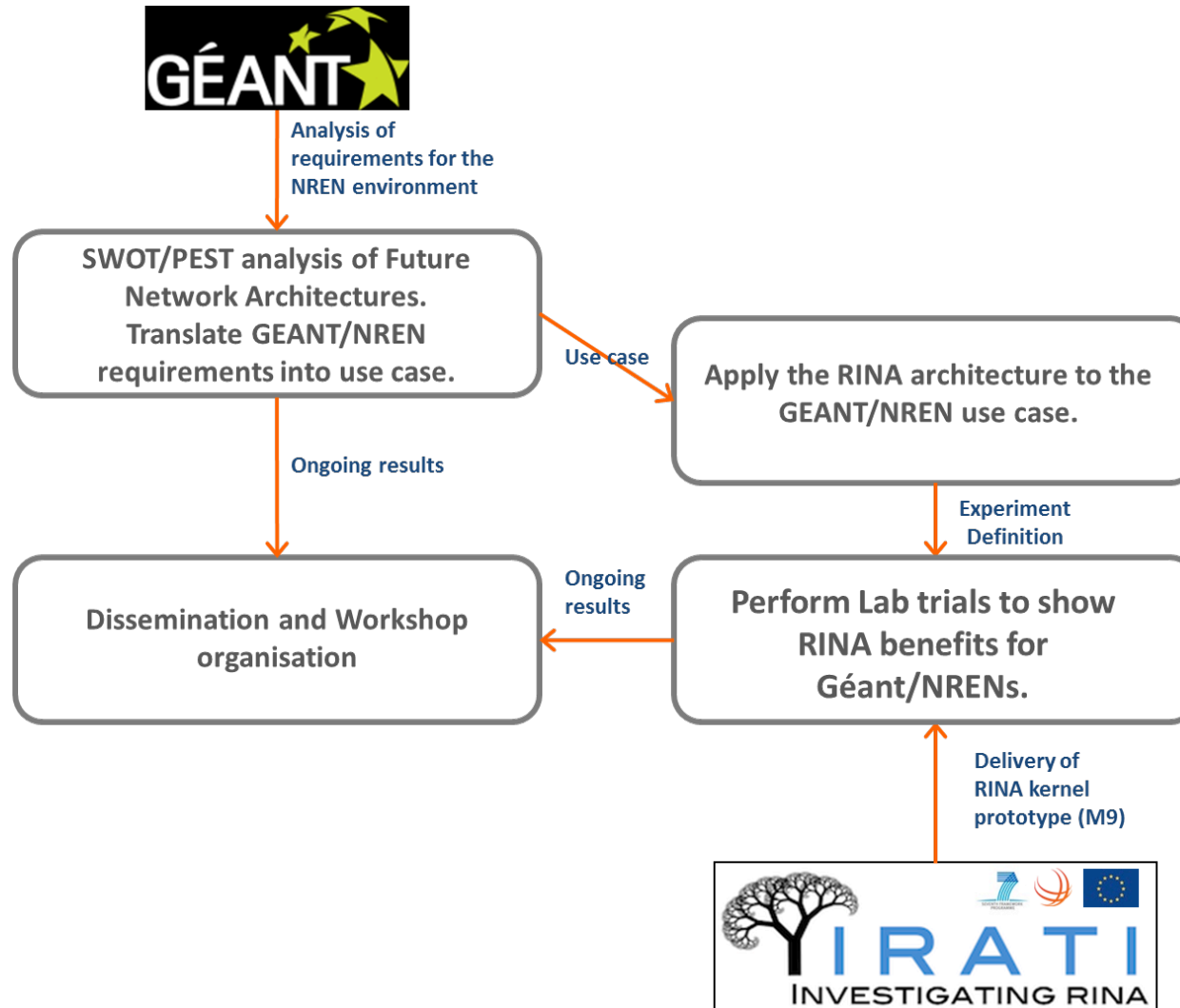

Programmability in RINA

FP7 PRISTINE – OVERVIEW

PRISTINE - Intro



- FP7 Project
 - Starts **Jan 2014**, ends **Jun 2016** (30 months)
 - 15 Partners (**Research**, **SMEs** and **Industry**)

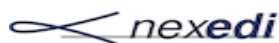

PRISTINE - Objectives

- **IRATI provides basic core packet transport functions**
- **PRISTINE designs some advanced functions:**
 - security of content and application processes,
 - congestion control
 - protection and resilience,
 - efficient topological routing
 - multi-layer management
- **Three use-cases**
 - Datacenter
 - Distributed cloud
 - Carrier network

PRISTINE FOCUS

