

draft-sajassi-bess-evpn-igmp-mld-proxy- 00.txt

A. Sajassi (Cisco), Keyur Patel (Cisco),
Samir Thoria (Cisco), Derek Yeung (Cisco),
J. Drake (Juniper), W. Lin (Juniper)

IETF 94, November 2015

Yokohama

Objectives

- To reduce flooding of IGMP messages (both Reports and Queries) in EVPN networks just similar to ARP/ND suppression mechanism that reduces flooding of ARP/ND messages over EVPN
- To Provide functionality of Anycast distributed host multicast router
- To forward multicast traffic efficiently over EVPN network to PEs that are have receivers for that $(*,G)$ or (S,G)

IGMP Proxy

- Proxy Reporting:
 - Terminate IGMP reports from downstream hosts/VMs
 - Summarize these reports in a new EVPN BGP route – draft specifies a set of rules for such summarization
 - Translate back into IGMP messages at the receiving EVPN PE when needed

IGMP Proxy – Cont.

- Proxy Querier:
 - To enable the collection of EVPN PEs providing L2VPN service to act as distributed multicast router with Anycast IP address for all attached hosts/VMs in that subnet.
 - To enable suppression of IGMP membership reports and queries over MPLS/IP core.
 - To enable generation of query messages locally to their attached host.

Operational Example

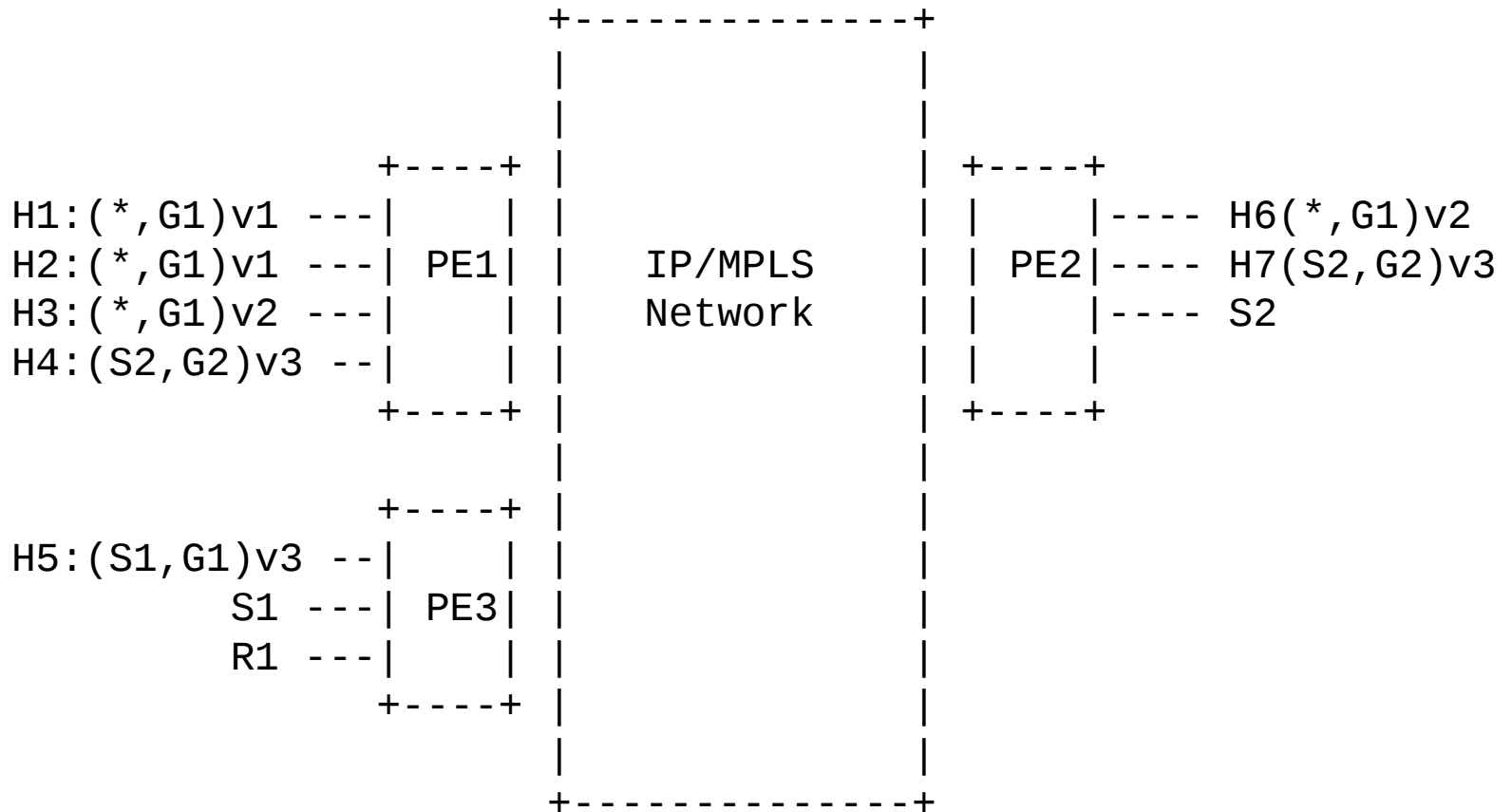

New EVPN BGP Route

```

+-----+
|  RD (8 octets)                |
+-----+
|  Ethernet Tag ID (4 octets)   |
+-----+
|  Multicast Source Length (1 octet) |
+-----+
|  Multicast Source Address (variable) |
+-----+
|  Multicast Group Length (1 octet)  |
+-----+
|  Multicast Group Address (Variable) |
+-----+
|  Originator Router Length (1 octet) |
+-----+
|  Originator Router Address (variable) |
+-----+
|  Flags (1 octets) (optional)      |
+-----+

```

```

    0  1  2  3  4  5  6  7
+--+--+--+--+--+--+--+
| reserved |IE|v3|v2|v1|
+--+--+--+--+--+--+--+

```

Next Step

- Questions ?