

RSVP PROTOCOL EXTENSIONS FOR
Resilient MPLS Rings
draft-deshmukh-rsvp-rmr-extension-00

IETF 96 (MPLS WG)

Abhishek Deshmukh

Kireeti Kompella (presenting)

Introduction

- draft-deshmukh-rsvp-rmr-extension-00 describes the RSVP extensions needed to support RMR
- RMR LSPs have a few differences with “regular” unicast RSVP-TE LSPs

Differences

- Ring LSPs (by construction) form a loop
- A Ring LSP is multipoint to point (MP2P)
 - Each RMR LSP has one egress node but can have multiple ingress nodes
 - The bandwidth of a ring LSP can change hop-to-hop (since it is MP2P)
- Ring LSP protection is akin to SONET/SDH ring protection

Extensions - Session Object

RMR_TUNNEL_IPv4 Session Object

Class = SESSION, RMR_TUNNEL_IPv4 C-Type = TBD

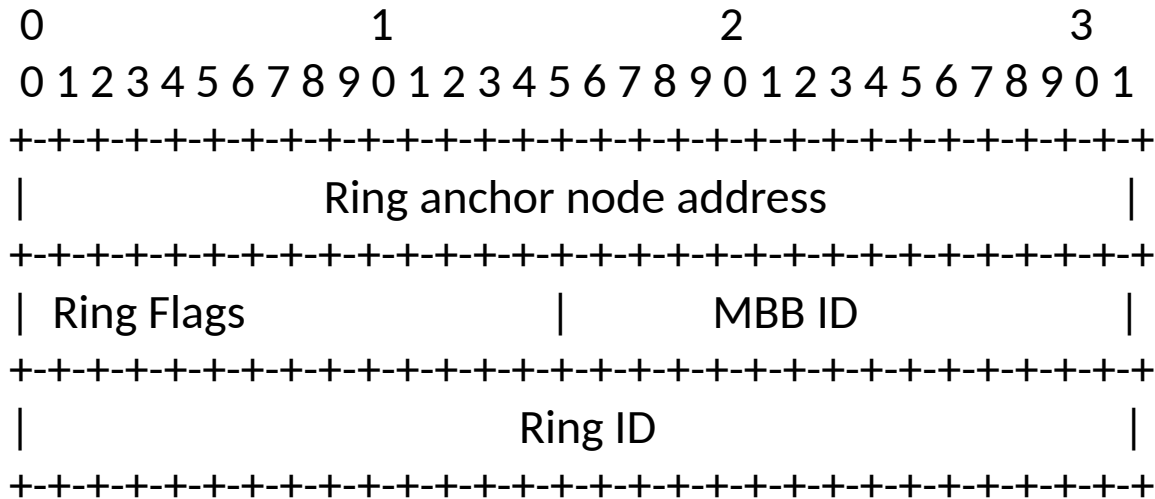

Ring anchor node address

IPv4 address of the anchor node. Each anchor node creates a LSP addressed to itself

Ring Flags

- 1 = Clockwise
- 2 = Anti-Clockwise

MBB ID

A 16-bit identifier used in the SESSION. This "Make- before-break" (MBB) ID is useful for graceful ring changes.

Ring ID

A 32-bit identifier for the ring.

Extensions - Sender Template Object

Sender Template & Filter Spec Object

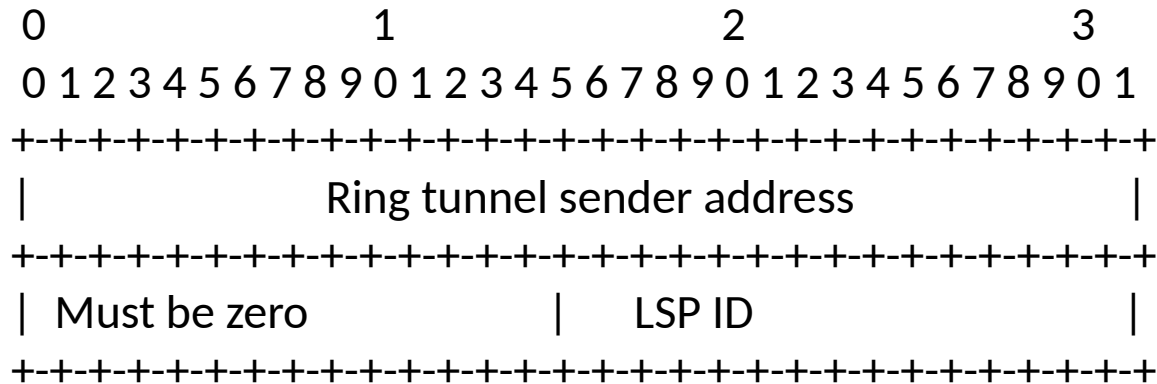

Ring tunnel sender address

IPv4 loopback address of the sender .

LSP ID

A 16-bit identifier used in the SENDER_TEMPLATE.

No changes to the format of SENDER_TEMPLATE and FILTER_SPEC objects.

Only the semantics of these objects will slightly change.

Different sender template & filter spec objects can be inserted by different nodes along the ring which can be used for RMR bandwidth management.

Ring LSPs: Bandwidth Management

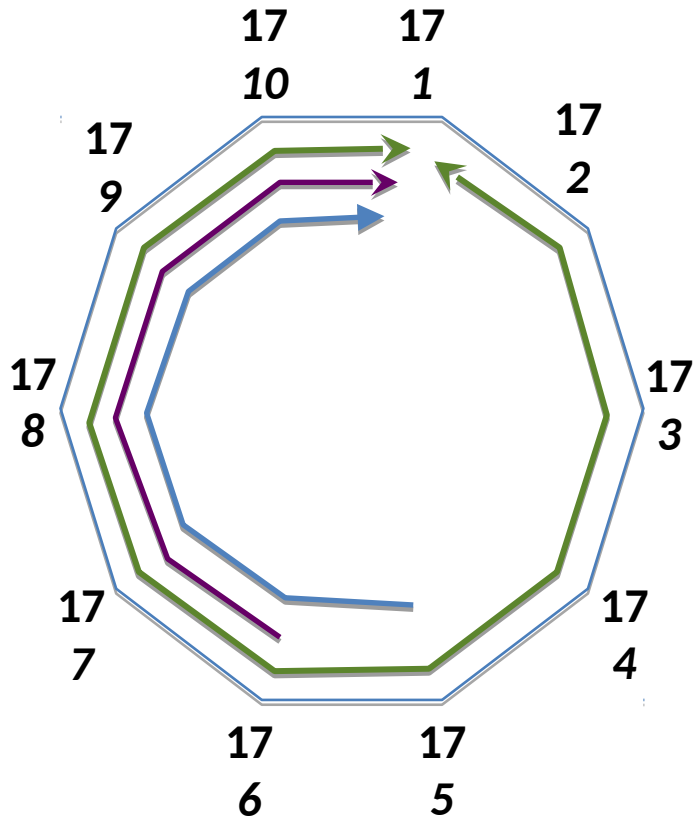

Let's say that the CW & AC anchor LSPs are already established for node 1 - LSP1. (Green arrow LSP)
Let's focus on the CW LSP.

Now, node 5 wants to achieve BW increase from 0G to 1G (Blue arrow LSP)

Similarly node 6 may want to increase BW (Purple arrow LSP)

Now, let's say, node 5 wants to increase bw again from 1G to 2G

Ring LSPs: Bandwidth Management

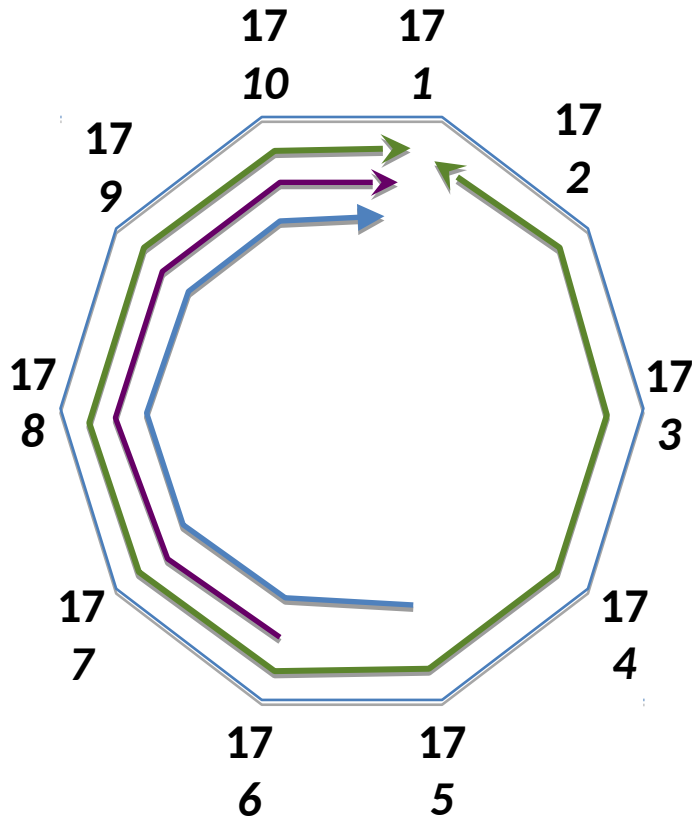

Let's say that the CW & AC anchor LSPs are already established for node 1 – LSP1. (Green arrow LSP)

To increase the BW, node 5 will signal a new Path message with a different sender-template object for “LSP1” towards node 1.

Ring tunnel sender address = node 5; lsp-id = 1
Node 1 will respond with Resv message for this new path if sufficient bw is available. This Resv message will have the appropriate filter-spec object. (Blue arrow LSP)

Similarly node 6 can increase BW by signaling a new Path message with different sender template object with its own address. (Purple arrow LSP)

If node 5 wants to increase bw again from 1G to 2G, then it will again create a new Path message for “lsp1” with Ring tunnel sender address = node 5 & lsp-id = 2

Ring LSPs: Bandwidth Management

- The goal is to achieve a smooth change of bandwidth without disrupting the existing LSP
- At the same time, if bandwidth is not available, the aim is to reject the update (again without disrupting the existing LSP) but targeted specifically to the requesting node

Ring LSPs: Bandwidth Management

- If sufficient BW is not available at some Downstream (say node 9), then ring node 9 will generate PathErr with the corresponding Sender Template Object.
- When ring node 5 no longer needs the bw reservation, then ring node 5 will originate a PathTear message with the corresponding Sender Template Object. Every downstream node will then remove bw allocated on the corresponding link.
- Note that we will not actually change any label as part of this bw increase. So, the label remains same as it is signaled initially for the anchor LSP. Only the BW accounting changes when these Path messages get signaled.

For Further Study

- Is an ERO needed for Ring LSPs?
- When a ring changes, how will Ring LSPs be maintained without disruption?
- What is the best way to use express links?