

# Session ID and Troubleshooting

Peter Dawes

IETF#83 Paris, France

# 9:00 am – session setup fails

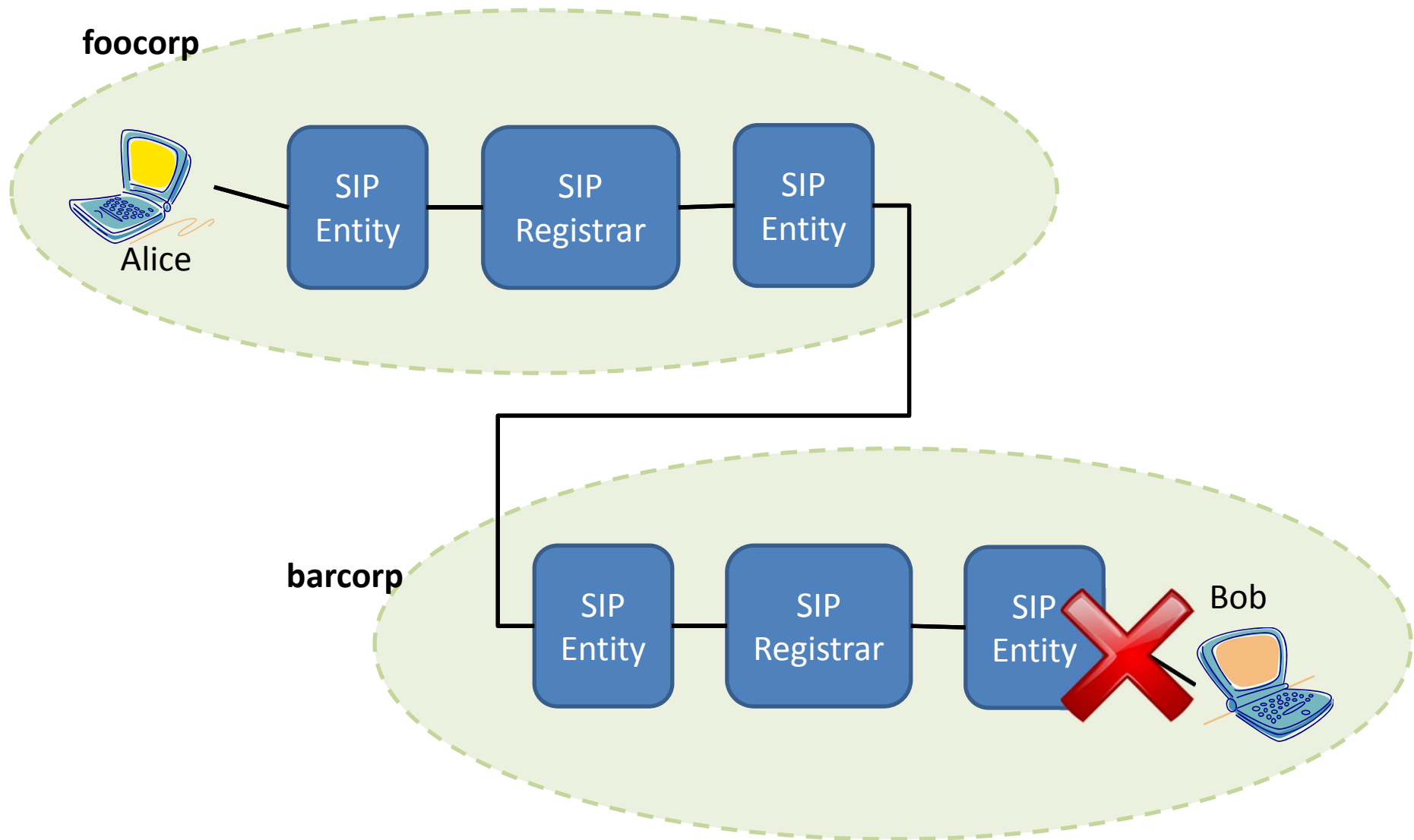

# 9:15am – no marking parameter

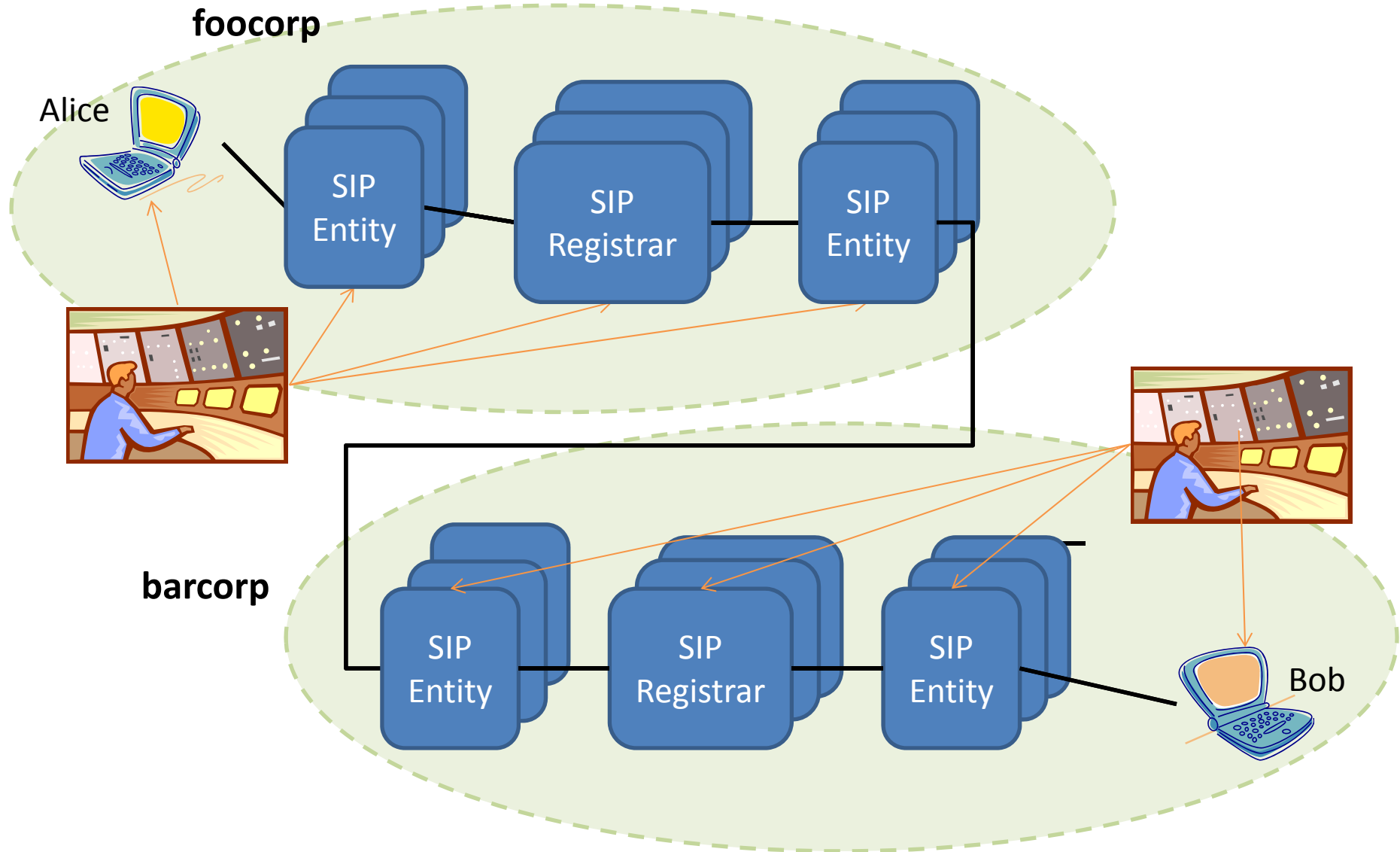

# Troubleshooting steps

- Both foocorp and barcorp configure all SIP entities that signalling might pass through to check for sessions initiated by Alice that fit criteria of the reported failure
- Might include unnecessarily configuring of a large number of SIP entities not on the signalling path
- Might require SIP entities to carry out complex checks on all SIP requests such as To:, From:, time of day, particular SIP method,...
- Ask Alice to initiate a session
- Re-configure all SIP entities to stop checking requests
- Collect logs (since no logging server defined)

# 9:15 am – with marking parameter

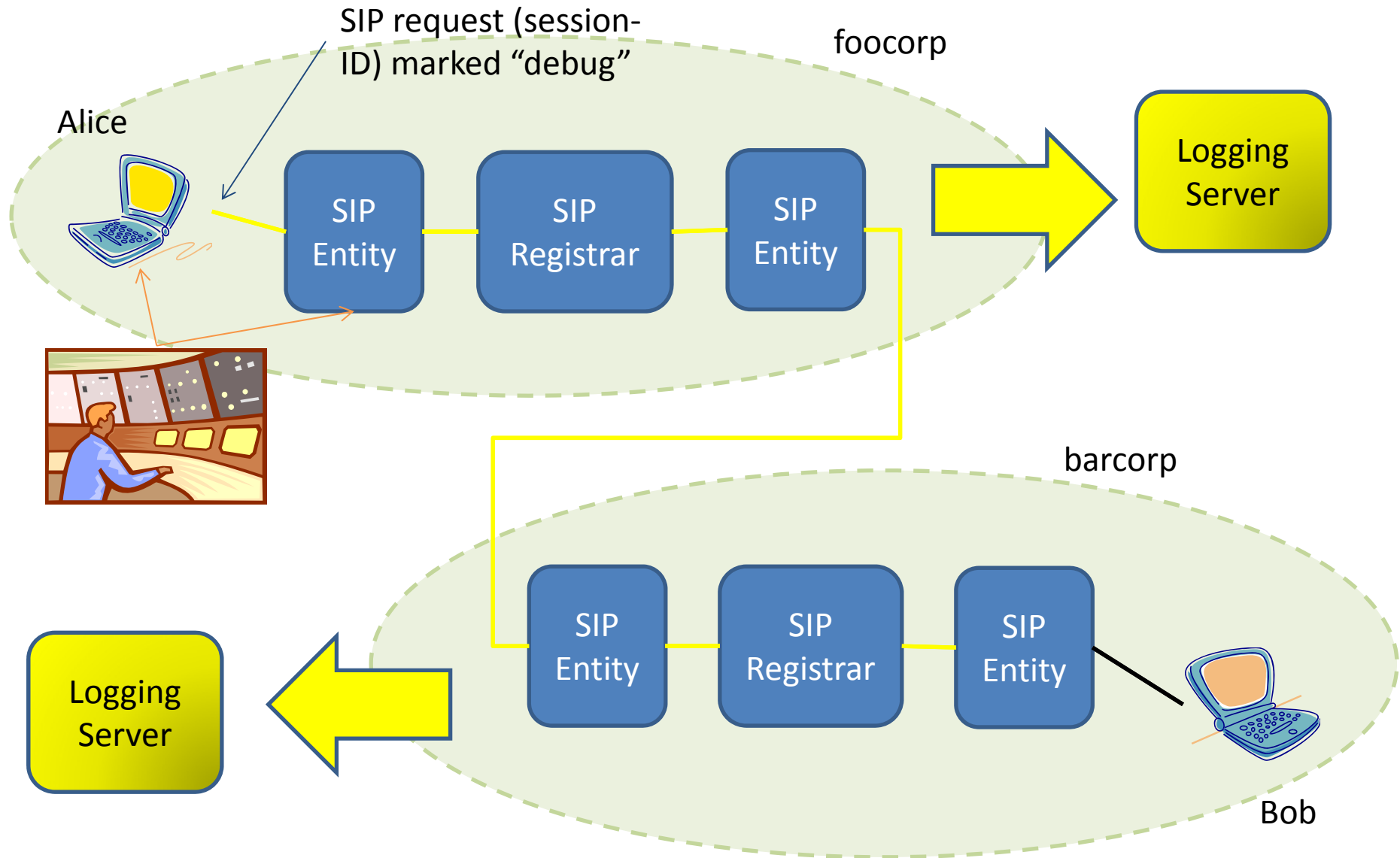

# Troubleshooting steps

- Only foocorp configures Alice's UA and first proxy to check for sessions initiated by Alice that fit criteria of the reported failure
- SIP entities have simple logic to log sessions, if the marking parameter (e.g. "debug") then log
- Ask Alice to initiate a session
- No need to configure SIP entities to stop checking and logging requests, safe to always check for marking parameter
- Logs automatically sent to logging server

# Proposed Session ID requirement

- "It must be possible to mark a session identifier as inserted for logging purposes"
- "...in order to keep network operations and maintenance steps and also SIP entity data volume and processing load to practical levels when troubleshooting"

# Example Open Mobile Alliance (OMA) requirements

- 3.2 Definitions

Marking	The operation of enabling a device or component to subsequently initiate the Service Level Tracing.
Marking request	A request initiated by the Service Provider or other authorized actor, which marks a device or component. The marking request contains the SLT start trigger event.
Marked device/component	A device or component that has been marked and has not been unmarked.

- 6.4 High-Level Functional Requirements for service level tracing

[SLT-HL-2]	A device/component supporting Service Level Tracing (SLT) MUST support marking.	
------------	---	--