

Switched Attribute and Spatial Coordinates

IETF CLUE Interim Meeting
June 2012

Andy Pepperell
[aepere@gmail.com](mailto:apeppere@gmail.com)

Switched attribute usage

- Usual case, 6 seats / 3 cameras:

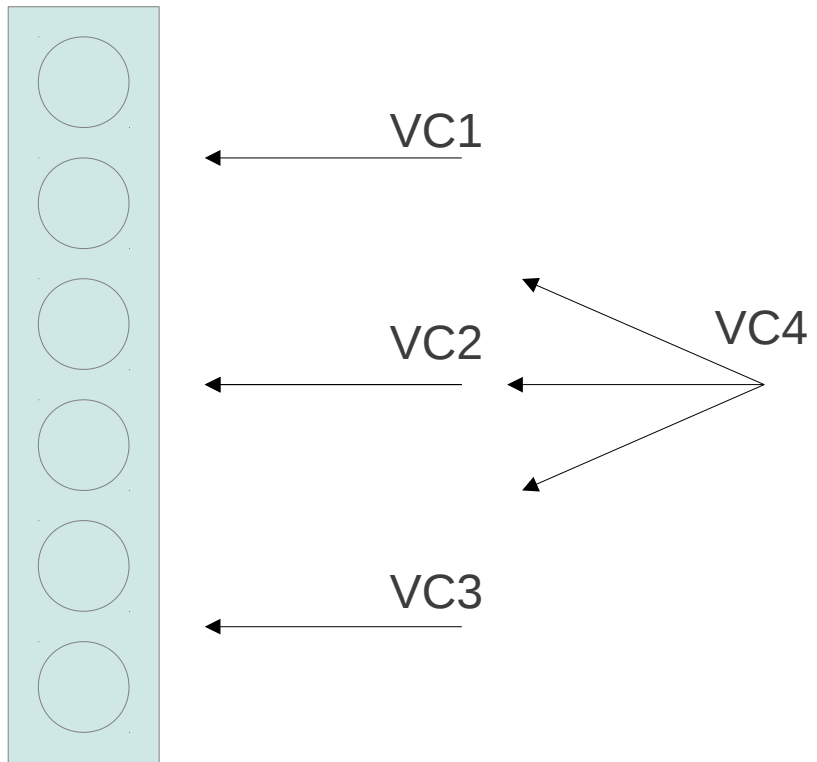

Capture scene entries	
1	VC1, VC2, VC3
2	VC4 ("switched")
3	[VC5 zoomed out view]

("switched" attribute may be the only way to distinguish VC4 and VC5 zoomed out view)

MCU (transcoded) case

- Handle 1, 2, and 3 screen consumers

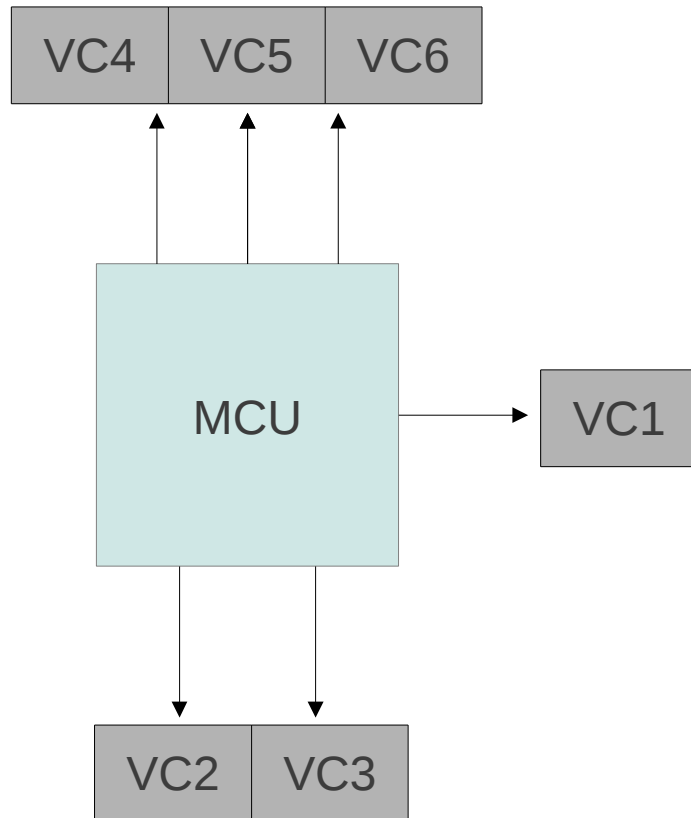

Capture scene entries	
1	VC1
2	VC2, VC3
3	VC4, VC5, VC6

Provider-side co-ordinates for VC1
– VC6 allow correct rendering by
consumer

What do we really want?

- Might be nice to allow:

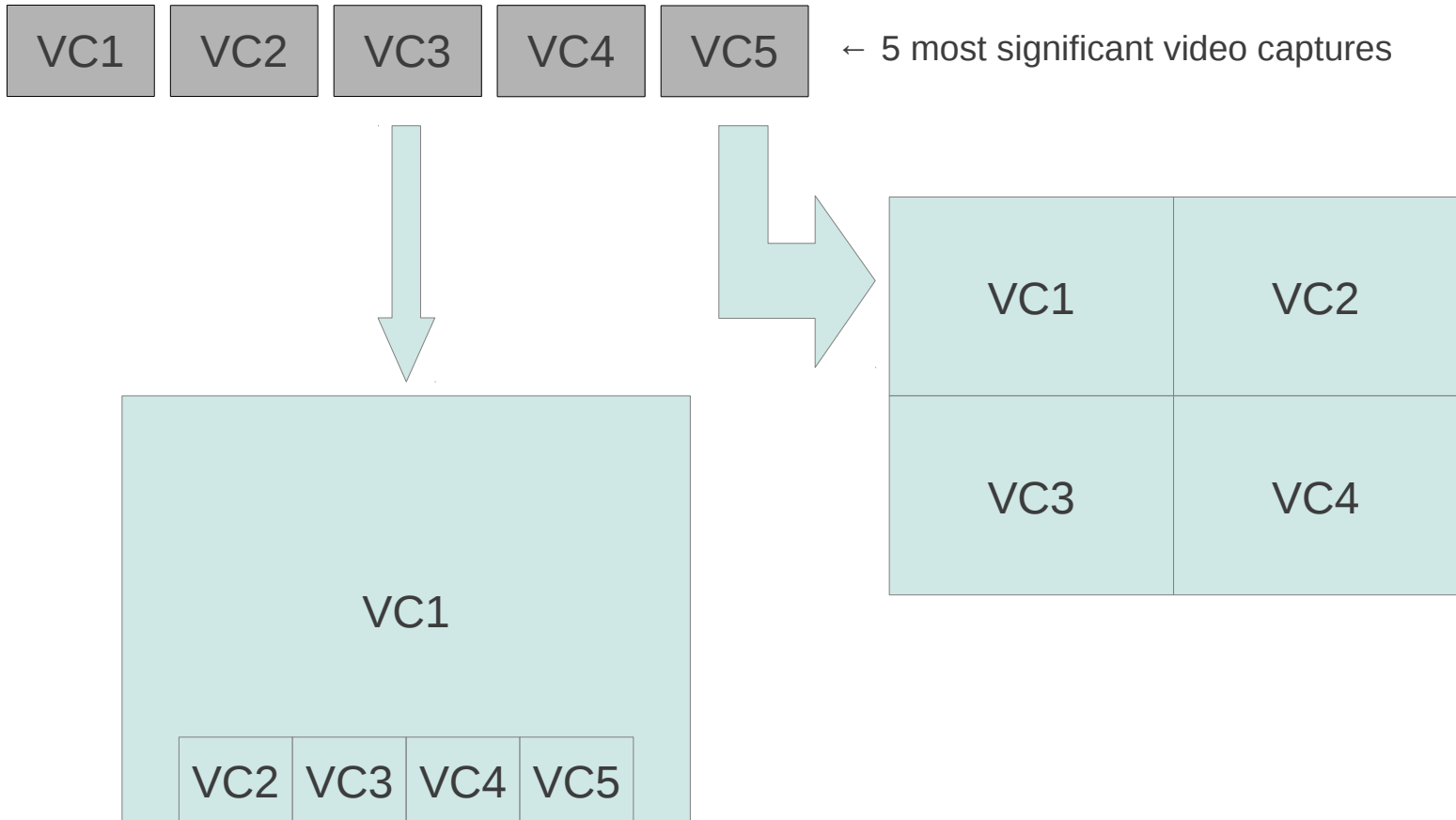

Previous slide explanation

- Middle box maintains ordered list of captures (VC1 – VC5)
 - typically ordered by audio energy
- Consumer performs own composition
- Desirable or essential...?
 - MCU may have no transcoding capabilities
 - Wish to reduce number of transcodes for quality or latency
 - Better / more appropriate layouts by consumer

Challenges

- **Challenge 1:**
 - Mechanism for advertisement and selection of ordered capture list
- **Challenge 2:**
 - Correct rendering of multi-capture sources from ordered capture list
- **Challenge 3:**
 - Lip sync of dynamically changing ordered captures

Challenge 1

- Different consumers want to use different number of captures, but undesirable to advertise full set:

Capture scene entries	
1	VC1
2	VC2, VC3
3	VC4, VC5, VC6
4	VC7, VC8, VC9, VC10
5	VC11, VC12, VC13, VC14, VC15
<i>n</i>	<i>"n" switched video captures</i>

(and similar for audio captures)

Challenge 1 proposal

- **Proposed solution:**
 - Use “switched” attribute and absence of provider-side capture co-ordinates to indicate a dynamic mapping
 - also implies validity of partial selection
 - differentiation of VCn and ACn needed for “transcoded” 1, 2, 3, 4, ... screen cases but not ordered switched captures

Challenge 2

- Not splitting multi-capture sources; consider:

VC1 VC2 VC3 Ordered participant 1 (“loudest”)

VC4 Ordered participant 2 (“second loudest”)

VC5 Ordered participant 3

VC6 Ordered participant 4

Challenge 2

- Valid distribution across 3 screens:

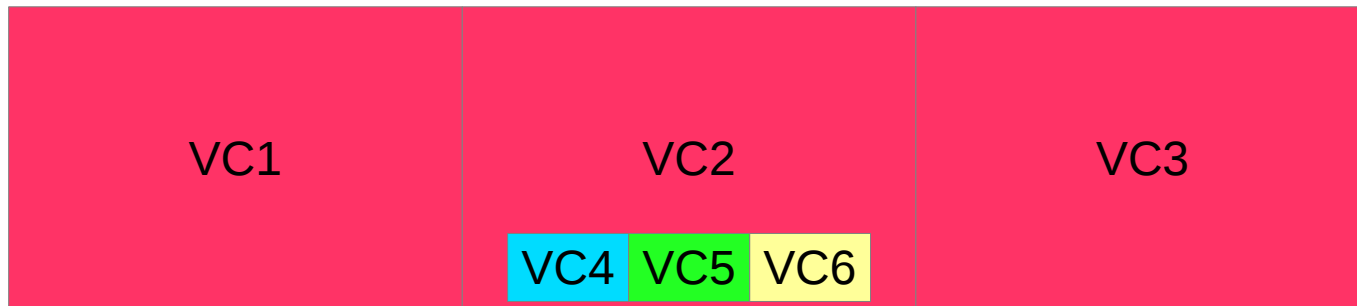

Challenge 2

- Naive, invalid, distribution of captures on 1 screen:

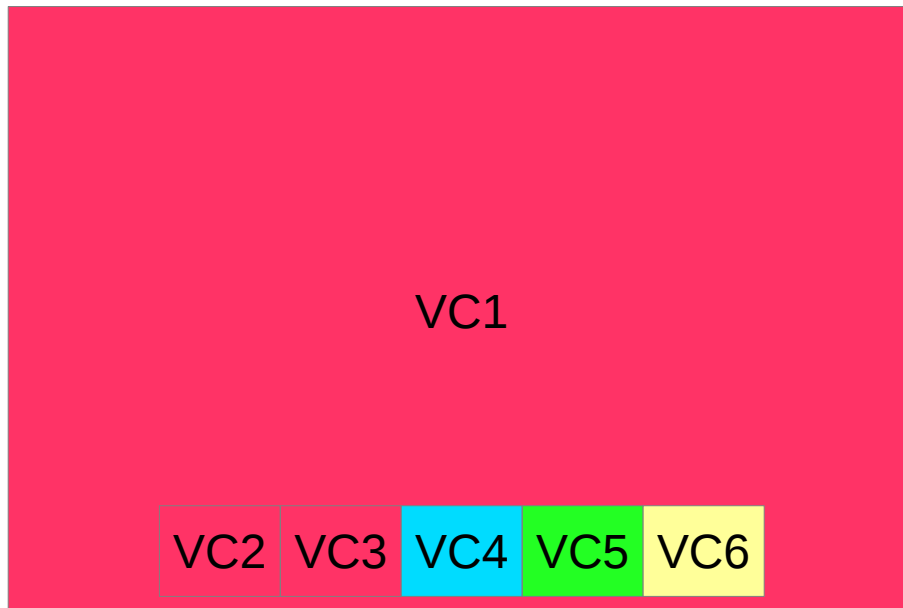

(VC1 – VC3 split
incorrectly)

Challenge 2

- Valid distribution on 1 screen:

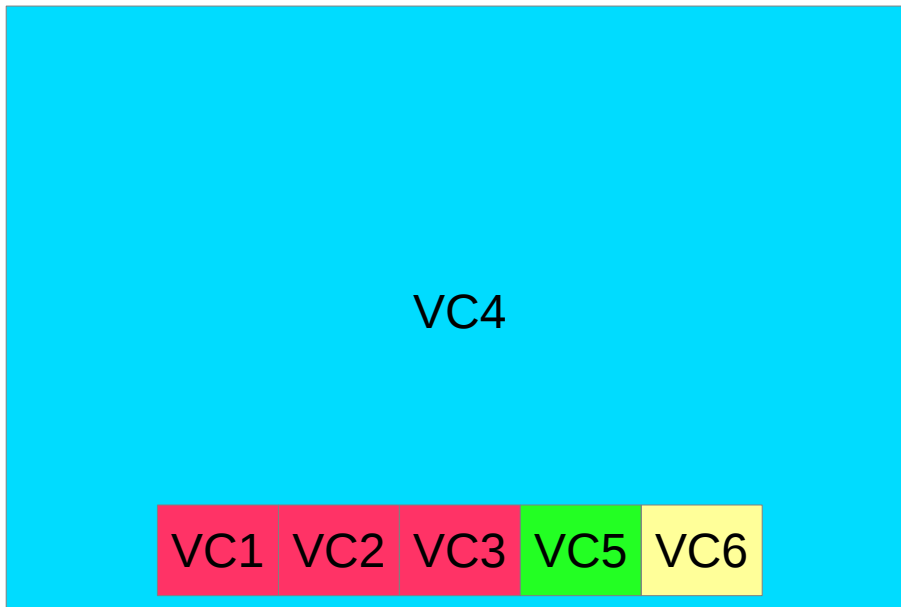

(VC1 – VC3 no longer split incorrectly)

Challenge 2 proposal

- Consumer needs to send some layout information to provider
 - Not full layout, but abstracted form of it
 - “rows” and “strips” simplifications considered
 - proposal instead is to introduce consumer-side render X, Y, Z co-ordinates
 - sent to provider along with consumer's capture instantiations
 - analog of provider co-ordinate scheme
 - dovetails co-ordinate absence for ordered capture list

Challenge 3

- With ordered audio and video captures changing frequently, how can lip sync be assured / achieved?
 - No static mapping between “n” ordered video captures and “m” ordered audio captures
 - Easy to see pathological cases when audio-only participants are involved, or when $n \neq m$

Challenge 3 proposal

- Ensure RTCP CNAME values used correctly
 - Should enable audio / video capture correspondence to be tracked
 - Expectation / assumption that active speaker order could change at a frequency that would require an RTP / RTCP solution here, i.e. that updates via CLUE messages would not be sufficiently “real time”

Alternative scheme

- Aforementioned proposals deliberately minimal
 - Absence of provider-side co-ordinates for “switched” captures implies capture scene entry from which it is valid to take a subset
 - Further implication that consumer should provider render-side co-ordinates
- Less minimal way of working:
 - Use an explicit capture set entry attribute to indicate this
 - However, implied case has the advantage of ascribing meaning to co-ordinate absence

Further study

- MCU \leftrightarrow MCU cascading cases; neither side providing co-ordinates
 - Consider EP \rightarrow MCU \rightarrow MCU \rightarrow EP