

Filter-Based RIB and Filter-Based Forwarding

Susan Hares

I2RS FB-RIB Design Team

*Did you ever have a moment
of déjà vu while writing a
Standard's document?*

*... IDR Flow Specification
and I2RS FB-RIB*

Why do Filter-Based FIB/RIBs Matter

- Forwarding filters
 - Simple forwarding Firewalls needed for forwarding sanity (ACLs)
- Better than Destination-Based forwarding
 - Policy-based Routing
- Uses for DDoS
 - Inter-Domain DoS protection
 - Intra-domain filters for TE of Network or DC
- SDN/NFV
 - Needing filters to guide traffic

Filter-Based RIBS

- **I2RS Filter-Based RIB (Forwarding) is not the only Filter-Based Forwarding**
 - Configuration level: ACLs, PBRs
 - Box/module Ephemeral: I2RS
 - BGP Session Level: BGP Flow Specification
- **Filter-Based Forwarding is Minimalistic ECA Policy**
 - **Event** = packet reception on interfaces
 - **Match Condition** = Match on Filters
 - **Actions** – Modify packet, and Forward (or Drop)
- **Should Filters be consistent or aligned at each layer?**

Routing instance

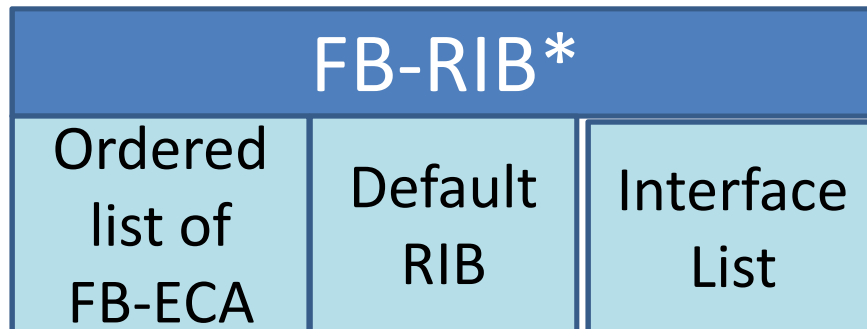

Interface 1

Interface 2

Interface 3

Interface 4



Name

Type

ECA Rule List

FB-Rule List

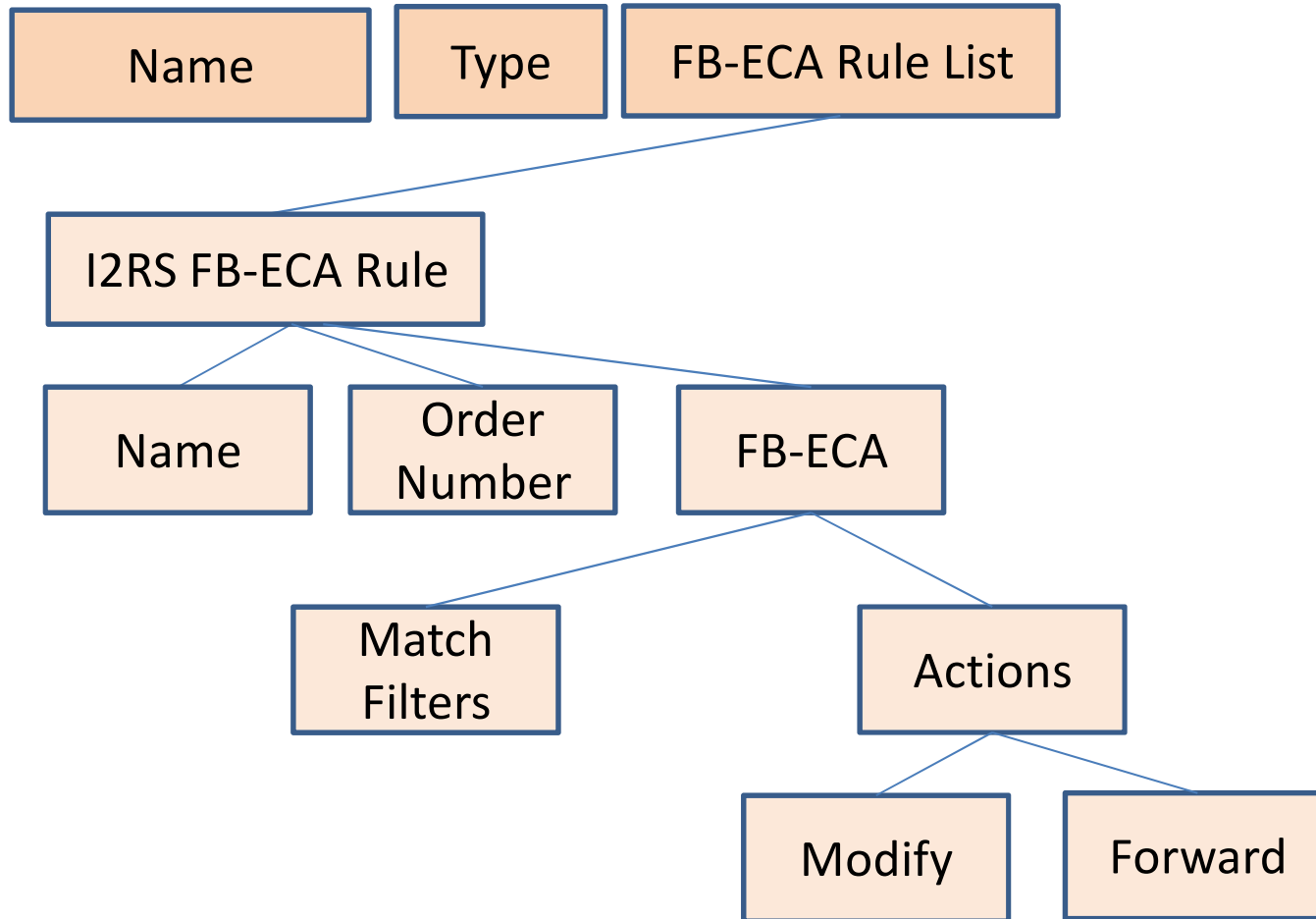

Contained in draft-hares-i2rs-pkt-eca-data-model

Filters in I2RS FB-RIB

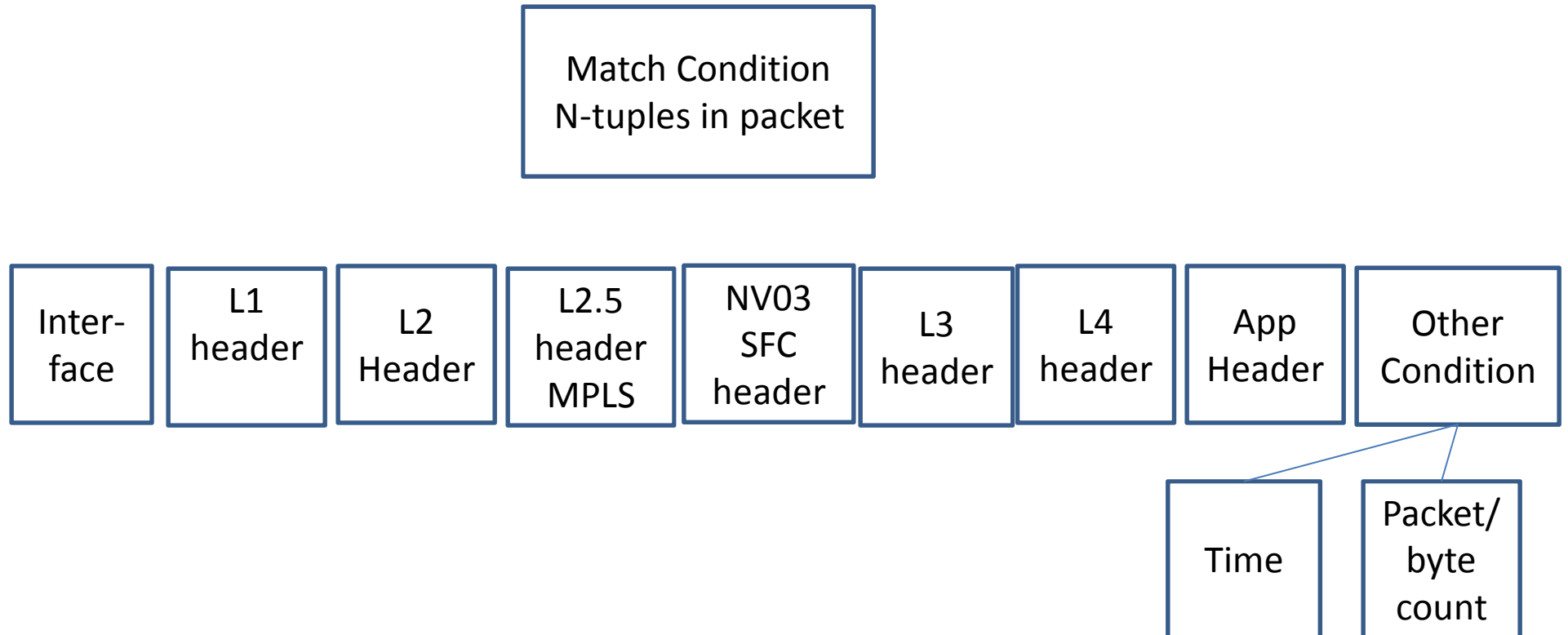

Draft-i2rs-kini-fb-rib-info-model

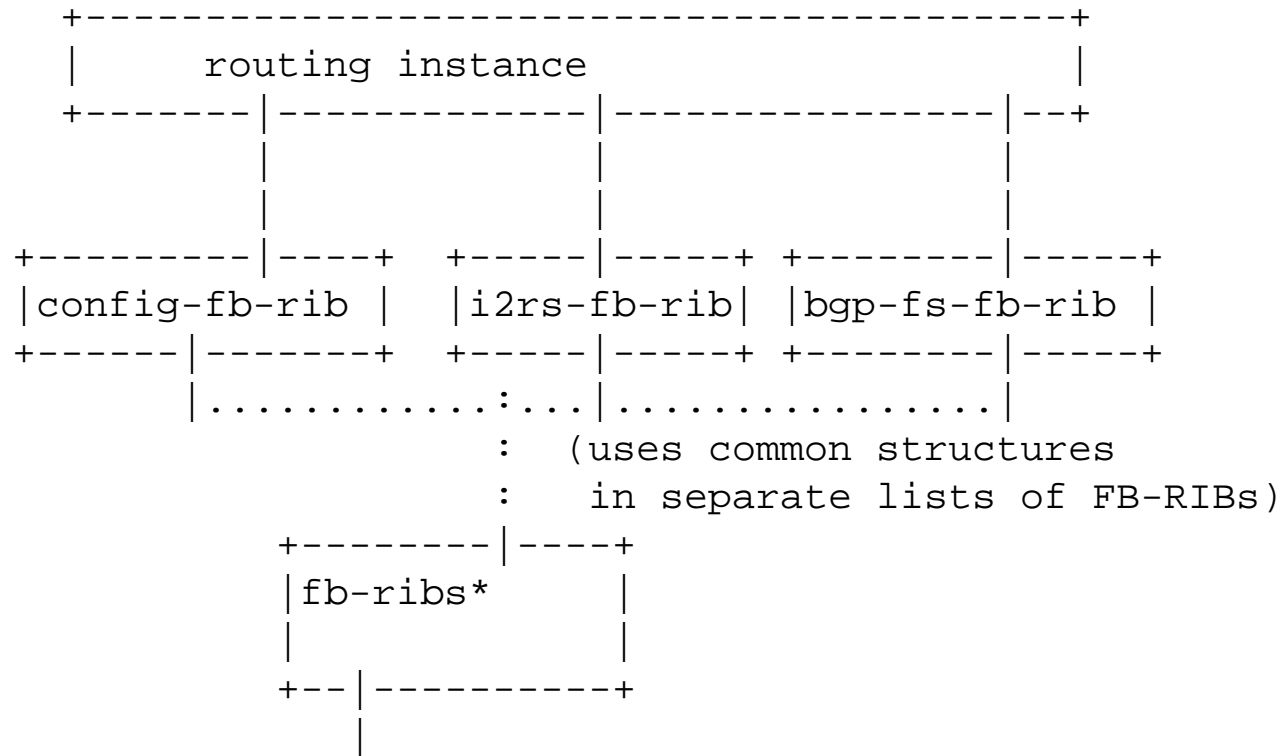

Top level Yang aligns

ietf-fb-rib module

+--rw ietf-fb-rib

+--rw default-instance-name string

+--rw default-router-id rt:router-id

+--rw config-fb-ribs

 if-feature "config-filter-based-RIB";

 uses fb-rib-t:fb-ribs;

+--rw i2rs-fb-ribs

 if-feature "I2RS-filter-based-RIB";

 uses fb-rib-t:fb-ribs;

+--rw bgp-fs-fb-ribs

 if-feature "BGP-FS-filter-based-RIB";

 uses fb-rib-t:fb-ribs;

Question for Discussion

- For Filter-Based Forwarding,
 - Is the I2RS level FB-RIB OK ?
 - Is Config + I2RS OK?
 - Is Config + I2RS + BGP Policy OK?
- For I2RS FB-RIB – use of default RIB
 - Just I2RS RIB or other RIBS
 - Other RIBs: Static route, BGP local FIB

BGP Flow specification (background only)

draft-hares-idr-bgp-flow-spec-
combo-00.txt

BGP Flow Specification

- Filters in NLRI with 2 SAFIs (133 IP, 134 IPVPN)
 - For SAFI 133: IPv4 (AFI=1), IPv6 (AFI=2), L2VPN (AFI=25), +++
 - For SAFI 134: IPv4 (AFI=1), IPv6 (AFI=2), L2VPN (AFI=25), +++
- Actions in Extended communities

BGP FS Filters types for RFC/WG documents

- RFC 5575 types/v6-draft
 1. Destination prefix
 2. Source prefix
 3. IPv4 protocol / IPv6 Next header
 4. Port (source or destination)
 5. Source port
 6. Destination port
 7. ICMP Type
 8. ICMP Code
 9. TCP Flags
 10. Packet length
 11. Traffic Class
 12. IPv4 Fragment
 13. IPv6 Flow ID
- L2VPN types
 14. Ethernet type
 15. Source MAC
 16. Destination MAC
 17. DSAP in LLC
 18. SSAP in LLC
 19. Control fields in LLC
 20. SNAP
 21. VLAN ID
 22. VLAN COS
 23. Inner VLAN ID
 24. Inner VLAN COS

Flow Specification Actions

Approved Actions (RFC 5575 and RFC 7674)

- Traffic rate in bytes (0x8006)
- Traffic Action (0x8007) with S(sample) T (terminal) flags
- Redirect to IP VPN via Route Target
 - RD 2 octet AS, 4 byte value (0x8008)
 - RD 4 octet IP, 2 byte value (0x8108),
 - RD 4 octet AS, 2 byte value (0x8208)

Proposed Actions

- (FA1) Traffic Rate in packets
- (FA2) Traffic Action with “R” for refer to more policy in BGP Attribute
- (FA3) Redirect to Tunnel
- (FA4) VLAN Action
- (FA5) TPID action
- (FA6) MPLS label action (push, pop, swap)
- (FA7) interfaces set
- (FA8) change validation to ROA or bgpsec-protocol

BGP FS Proposed Filter types

Proposed BGP Flow Specification types

- MF-1 NV03 Delimiter
 - Inner/outer header info
- MF-2 Virtual Network ID (VNID)
- MV-3 Flow ID (NVGRE Flow ID)

Implied – but not proposed yet

- MF-4 MPLS LSP label or label stack
- MF-5 Interface Grouping
- MF-6 Time matches

Create more Flow Specification types

Two ways to combine Rules

- Default setting of order and action precedence - or
 - BGP Flow Specification – and it is causing problems for extensions
- Specified Order within rule and groups
- Order and then precedence within order
 - ACL, PBR, I2RS

BGP Flowspec vs. I2RS Filters

component	BGP Flow Spec ECA	I2RS FB-RIB Packet-ECA
Policy	flowspec-policy	rule-group
+-name	+-policy-name	+-group-name
+-vrf	+-vrnf-name	
+-AFI	+-address-family	
+-rule	+-flowspec-rule [rule-name]	+rule[rule-name]
+-name	+-rule-name	+-rule-name
+order		+-rule-order
+installer		+-installer
+-match- filter	+-flowspec- component	+-eca-match- filter
+-type	+-component- type	+-match type
+-intf	+-Intf Group	+intf

Bgp Flow Spec vs I2RS Filters

component	BGP Flow Spec ECA	I2RS FB-RIB Packet-ECA
More filters		
+--intf	+--Intf Group	+intf
+--L1		+l1 header
+--L2		+L2 header
+--MAC		+--MAC
+--L2VPN	+--l2VPN	+--L2VPN
+--MPLS	+--MPLS	+--MPLS
+--Nvo3	+--NV03	+--NVO3
+--L3	+--L3	+--L3 header
+dst IP	+dst IP	+dst-ip
+src IP	+src IP	+src-ip
+proto	+proto	+proto
+dscp	+dscp	+dscp
+ICMP	+icmp type	+icmp type
	+icmp value	+icmp code
+v6flow	+v6-flow-id	+v6flow
+--L4	+L4	+--L4-header
+S-port	+src port	+src-port
+d-port	+dst port	+dst-port

BGP FS vs. I2RS Filters Yang

component	BGP Flow Spec	I2RS FB-RIB
	ECA	Packet-ECA
... operational state		
+ro flow-	+ro-flowspec-	+ro fb-rib opstate
state	state	(need to add)
...
Operational Statistical State		
+ro flow-	+ro-flowspec-)(need to add)
stats	stats	

Question for Discussion

- For Filter-Based Forwarding,
 - Can we align the Filters at different levels?
 - Session Ephemeral: BGP Flow Specification,
 - Reboot Ephemeral: I2RS FB-RIB
 - Config: Policy-Based Routing (aka Forwarding)
 - Config: ACL
 - What “N-Tuples” filters should be standardized?
 - What Actions should be standardized
- For I2RS FB-RIB – use of default RIB
 - Just I2RS RIB or other RIBS
 - Other RIBs: Static route, BGP local FIB

BGP Flow Specification FB-ECA

Action Conflicts (2)

Possible conflicts											
Action	Traffic rate Bytes	Traffic Rate Pkts	Traffic Action	Ext. Traffic Action	Redirect To IP VPN	Redirect to IP Tunnel	VLAN	TPID	Label	Intf Set	BGP valid
Redirect IP VPN						X	X	X	X	X	
Redirect Tunnel					X		X	X	X	X	
VLAN					X	X		X	X	X	
TPID					X	X	X		X	X	
Label					X	X	X	X		X	
Intf. Set					X	X	X	X	X		